



Lime Down

Solar Park

Environmental Statement

Volume 3, Appendix 8-1: Landscape and Visual Impact Assessment Methodology (Clean)

May 2026

Revision 2

Planning Inspectorate Reference: EN010168

Document Reference: APP/6.3

APFP Regulation 5(2)(a)



Schedule of Changes

Revision	Section Reference	Description of Changes	Reason for Revision
2	Section 5	Updated text to provide further clarity regarding how the ground level is defined within the 3D modelling	Updated to provide clarification on the BESS and substation parameter boxes which have been modelled using the highest existing ground level within the relevant infrastructure footprint.

List of Contents

1	Landscape and Visual Impact Assessment Methodology	1
1.1	Introduction	1
1.2	Terminology	2
1.3	Assessment Approach	4
1.4	Baseline Assessment	6
1.5	Approach to Mitigation	9
1.6	Assessment of Landscape Effects	13
1.7	Assessment of Visual Effects	24
1.8	Nature of Effects	33
1.9	Significance of Effect and Criteria	33
2	Cumulative Assessment Methodology	36
2.1	Introduction	36
2.2	Types of Cumulative Effects	37
2.3	Approach to Assessment	40
2.4	Assessment of Cumulative Site Effects	40
2.5	Assessment of Cumulative Development Effects	41
3	Residential Visual Amenity Assessment Methodology	42
3.1	Introduction	42
4	Zone of Theoretical Visibility (ZTV) Methodology	45
	LVIA Glossary	46
	References	50
5	Photography and Photomontage Methodology	51

List of Tables

Table.8.1.1.1:	Examples of Embedded Mitigation	10
Table 8.1.1.2:	Criterion for Assessing the Value of Undesignated Landscapes	14
Table 8.1.1.3:	Landscape Receptor Value	16
Table 8.1.1.4:	Landscape Receptor Susceptibility to Change	17
Table 8.1.1.5:	Landscape Receptor Sensitivity Criterion	18
Table 8.1.1.6:	Matrix for Determining Landscape Sensitivity	20
Table 8.1.1.7:	Magnitude of Landscape Change: Duration and Reversibility	21
Table 8.1.1.8:	Overall Magnitude of Landscape Change	22
Table 8.1.1.9:	Value Attached to Views	27
Table 8.1.1.10:	Visual Receptor Susceptibility to Change	28
Table 8.1.1.11:	Visual Receptor Sensitivity Criterion	29

Table 8.1.1.12: Matrix for Determining Visual Sensitivity	30
Table 8.1.1.13 Overall Magnitude of Visual Change	32
Table 8.1.1.14: Matrix for Determining Significance of Landscape and Visual Effects	34
Table 8.1.1.15: Categories of Landscape and Visual Effects	34

1 Landscape and Visual Impact Assessment Methodology

1.1 Introduction

1.1.1 The assessment methodology follows the 'Guidelines for Landscape and Visual Impact Assessment' Third Edition (GLVIA3) (Ref.1). As recommended by GLVIA3, the process concentrates on principles and process, stating that 'It does not provide a detailed or 'formulaic' recipe that can be followed in every situation – it remains the responsibility of the professional to ensure that the approach and methodology adopted are appropriate to the task in hand'. The methodology that underpins the Landscape and Visual Impact Assessment (LVIA) process is therefore tailored to be proportionate to the assessment and nature and location of the Scheme. The methodology also considers the following guidance:

- An Approach to Landscape Character Assessment (October 2014) (Ref.2).
- Landscape Institute (17 September 2019) Technical Guidance Note 06/19 Visual Representation of Development Proposals (Ref.3).
- Landscape Institute (26 May 2021) Technical Guidance Note 02/21 Assessing landscape value outside national designations (Ref.4).
- Landscape Institute Draft Technical Guidance LITGN-2024-01 (August 2024) Notes and Clarifications on Aspects of Guidelines for Landscape and Visual Impact Assessment Third edition (GLVIA3) (Ref.5).

1.1.2 GLVIA3 advises that LVIA must deal with and clearly distinguish between the assessment of landscape effects and the assessment of visual effects. This is set out in paragraphs 2.21 and 2.22:

- *“Assessment of landscape effects: assessing effects on the landscape as a resource in its own right;*
- *Assessment of visual effects: assessing effects on specific views and on general visual amenity experienced by people.*

The distinction between these two aspects is very important but often misunderstood, even by professionals. LVIA must deal with both and should be clear about the differences between them. If a professional assessment does not properly define them or distinguish between them, then other professionals and members of the public are likely to be confused.”

1.1.3 The significance of landscape and visual effects is determined through consideration of the sensitivity of the receptor and the magnitude of change. Sensitivity is judged through consideration of the value of the landscape or view, and the susceptibility of the receptor to change.

- 1.1.4 The time period for the assessment covers the construction of the Scheme and associated infrastructure, to completion of the works and the commencement of its operation and decommissioning, including identification of residual effects. Matters of residual effects are set out in Figure 4.7 of GLVIA3.
- 1.1.5 The assessment involves a process of iterative design and re-assessment of any remaining, residual effects that would not otherwise be mitigated or 'designed out'. The type of effect is also considered and may be direct or indirect; temporary (reversible) or permanent; and Beneficial, Neutral, or Adverse. The landscape and visual appraisals unavoidably involve a combination of both quantitative and qualitative assessment and wherever possible a consensus of professional opinion is sought through consultation, internal peer review, and the adoption of a systematic, impartial, and professional approach.

1.2 Terminology

- 1.2.1 A description of the definitions, scope and context of the terminology used in the LVIA process is provided in the Glossary of this methodology.
- 1.2.2 GLVIA3 (paragraph 1.15) identifies with regard to impacts, effects and significance that 'Terminology can be complex and potentially confusing in this area, particularly in the use of the words 'impact' and 'effect' in LVIA within EIA and SEA'. In this case, it encourages the consistent use of the terms 'impact' and 'effect' but recognises that there may be circumstances where this is not appropriate, for example where other practitioners involved in an EIA are adopting a different convention and states that:
- "This applies to 'appraisals' of landscape and visual impacts outside the formal requirements of EIA as well as those that are part of formal assessment."*
- 1.2.3 For the purpose of the LVIA process, the methodology adopts the consistent use of terms to ensure that the same meaning and ultimate judgements are applied in a transparent way throughout the assessment process. Clarity on the use of terms in the LVIA process is set out below.

Sensitivity of Receptor

- 1.2.4 This judgement is established by considering the concept of value of the receptor combined with the susceptibility of the receptor to specific change. The combination of these two criteria then informs the sensitivity of landscape and visual receptors as set out in paragraphs 1.6.12 to 1.6.15 and 1.7.13 to 1.7.15 below.
- 1.2.5 For the purpose of the LVIA process, a receptor sensitivity is classified on a four-point scale of: very low, low, medium, and high (refer to **Tables 8.1.1.5** and **8.1.1.11** of this Methodology). This division is not black and white and in reality, there will be a gradation in the judgement of sensitivity of receptors.

Resource / Receptor Value

- 1.2.6 The concept of value of the receptor is related to a range of factors and indicators. This list of factors is not fixed as the criteria need to be appropriate to each designation process.
- 1.2.7 In terms of value of the Landscape Character Types or Areas, this would, for example, relate to any designations at both national and local levels, and where there are no designations, judgements are based on criteria set out within the Landscape Institute technical guidance note (TGN) (Ref.6) that provides information and guidance to landscape professionals and others who need to make judgements about the value of landscapes (outside national landscape designations).
- 1.2.8 In terms of the value of local landscape designations, this would for example relate to locally valued landscapes such as Special Landscape Areas or Areas of Great Landscape Value. For these receptors, it is necessary to understand their reasons for designation and to examine how the criteria relate to the area in question in order to make judgements on their value.
- 1.2.9 In terms of visual receptors, this would for example relate to recreation and enjoyment and to the recognition attached to a particular view by visitors (through appearances in guidebooks or on tourist maps and the provision of facilities such as car parking and interpretation). These visual receptors would include road users, walkers, and horse riders, but would also include users of waterways (boats), leisure cyclists and train users, where appropriate.
- 1.2.10 In terms of landscape receptors, this would for example relate to local distinctiveness and sense of place where the landscape may be designated for its cultural associations.
- 1.2.11 For the purpose of the LVIA process, a receptor value is classified on a four-point scale of: very low, low, medium, and high (refer to **Tables 8.1.1.3** and **8.1.1.9** of this Methodology). This division is not black and white and in reality, there will be a gradation in the judgement of resource/receptor value.

Susceptibility to Change

- 1.2.12 Susceptibility to change is not recorded as part of the baseline situation but is instead considered as part of the assessment of effects and tailored to the project.
- 1.2.13 In terms of landscape receptors, susceptibility to change means the ability to accommodate the Scheme without undue consequences for the maintenance of the baseline situation and/or achievement of landscape planning policies and strategies.

- 1.2.14 In terms of visual receptors, this is a product of the occupation or activity of people experiencing the view and the extent to which their attention or interest may therefore be focused on the views and visual amenity they experience.
- 1.2.15 For the purpose of the LVIA process, susceptibility to change is classified on a four-point scale of: very low, low, medium, and high (refer to **Tables 8.1.1.4** and **8.1.1.10** of this Methodology)). This division is not black and white and in reality, there will be a gradation in the judgement of susceptibility to change.

Magnitude of Change

- 1.2.16 Magnitude of change is gauged by assessing the type and amount of change predicted to occur as a result of the Scheme in relation to the specific landscape or visual receptor. Factors influencing the magnitude of change include: size or scale; geographical extent; and duration and reversibility of effect as set out in Paragraphs 1.6.17 to 1.6.23 and 1.7.22 to 1.7.31.
- 1.2.17 For the purpose of the LVIA process, the overall magnitude of change is classified on a four-point scale of: very low, low, medium, and high (refer to **Tables 8.1.1.8** and **8.1.1.13** of this Methodology)). This division is not black and white and in reality, there will be a gradation in the judgement of magnitude of change.

Significance of Effects

- 1.2.18 Significance of landscape and visual effects is gauged by considering the magnitude of change along with the sensitivity of the receptor using professional judgement.
- 1.2.19 For the purpose of the LVIA process, the significance of effects is set out within Section 1.9, for example: negligible, minor, moderate to minor, moderate, major to moderate and major (**Table 8.1.1.14** of this Methodology)). This division is not black and white and in reality, there will be a gradation in the judgement of significance of effects.
- 1.2.20 In line with good practice guidance set out in GLVIA3 (paragraph 1.17), in addition to assessing significance, effects are classified as: beneficial (positive), adverse (negative) or neutral, as well as direct and indirect. An effect is understood to be neutral when the predicted residual change would, on balance, result in neither an improvement, nor a deterioration of the landscape and visual resource compared with the existing situation.

1.3 Assessment Approach

- 1.3.1 The assessment of landscape character and visual amenity is both a subjective and objective process. Whilst subjectivity can never be removed, by following a systematic and robust step by step process, rational and transparent conclusions can be drawn.

- 1.3.2 The process of LVIA is therefore based on the following principles and processes:
- Baseline appraisal including desk based and field surveys to identify the nature of the existing landscape and visual resource;
 - Identification of the individual landscape and visual receptors likely to experience change from the Scheme and a description of the effects, both adverse and beneficial;
 - An assessment of the significant effects identified; and
 - Identification of any additional mitigation or monitoring measures that may be required.
- 1.3.3 In accordance with GLVIA3 (paragraphs 2.20 and 2.21), the assessment of landscape and visual effects are separate but linked procedures; the landscape is assessed as an environmental resource in its own right, whereas visual effects are assessed on views and visual amenity experienced by people.
- 1.3.4 Landscape effects are concerned with the effects of the Scheme on the character of the landscape, combined with an understanding of the proposed change or development. Key steps in the process defined by GLVIA3 (paragraph 5.34), are as follows.
- *“The first step is to identify the components of the landscape that are likely to be affected by the scheme, often referred to as the landscape receptors, such as overall character and key characteristics, individual elements or features, and specific aesthetic or perceptual aspects.*
 - *The second step is to identify interactions between these landscape receptors and the different components of the development at all different stages, including construction, operation and, where relevant, decommissioning and restoration/reinstatement.”*
- 1.3.5 Visual effects are concerned with changes in available views of the landscape and the effect of those changes on people, often referred to as visual receptors. A range of issues to assist in describing effects on views (not restricted to) are defined in GLVIA3 (paragraph 6.27), as follows:
- *“The nature of the view of the scheme, for example a full or partial view or only a glimpse;*
 - *The proportion of the scheme or particular features that would be visible (such as full, most, small, part, none);*
 - *The distance of the viewpoint from the development and whether the viewer would focus on the development due to its scale and proximity or whether the development would be only a small minor element in a panoramic view.*

- *Whether the view is stationary or transient or one of a sequence of views as from the footpath or moving vehicle*
- *The nature of the change's which must be judged individually for each project but may include, for example, changes in the existing skyline profile, creation of a new visual focus in the view, introduction of new man-made objects, changes in visual simplicity or complexity, alteration of visual scale and change to the degree of visual enclosure."*

1.3.6 It is important to recognise that the LVIA process is an integral part of the design process. Following an initial assessment of the baseline conditions and consultation, the embedded mitigation and enhancement measures are fed back into the development proposals and its design as part of an iterative approach.

Consultation

1.3.7 In terms of consultation, the Guidelines for Landscape and Visual Impact Assessment (GLVIA3) notes that *"In general the EIA procedures only formally require consultation with the public at the stage of submission and review of the Environmental Statement, although in some cases there may be a requirement for pre-application consultation. Nevertheless, there are considerable benefits to be gained from involving the public in early discussion of the proposals and of the environmental issues that may arise. This can make a positive contribution to scoping the landscape and visual issues"* (Ref.7).

1.3.8 The Guidance also notes that: *"Consultation is an important part of the Landscape and Visual Impact Assessment process, relevant to many of the stages described above. It has a role in gathering specific information about the site, and in canvassing the views of the public on the proposed development. It can be a valuable tool in seeking understanding and agreement about the key issues and can highlight local interests and values which may otherwise be overlooked. With commitment and engagement in a genuinely open and responsive process, consultation can also make a real contribution to schemed design"* (Ref.8).

1.4 Baseline Assessment

1.4.1 GLVIA3 sets out the requirements of the Baseline Assessment as follows:

- *"For the landscape baseline the aim is to provide an understanding of the landscape in the area that may be affected – its constituent elements, its character and the way this varies spatially, its geographic extent, its history (which may require its own specialist study), its condition, the way the landscape is experienced, and the value attached to it.*
- *For the visual baseline the aim is to establish the area in which the development may be visible, the different groups of people who may*

experience views of the development, the places where they will be affected and the nature of the views and visual amenity at those points.”

- 1.4.2 The landscape and visual baseline conditions of the assessment are established by undertaking a detailed desk study, fieldwork, and analysis of findings to create a detailed understanding of the existing landscape and visual context of both the Solar PV Sites and Cable Route and the surrounding landscape within the proposed Study Area.
- 1.4.3 Together, the established baseline provides an understanding of the components of the landscape and visual resource that may be affected by the Scheme, which includes the identification of key landscape and visual receptors which represent the existing situation. The baseline for the LVIA process is of sufficient detail to enable a well-informed assessment of the likely landscape & visual effects on the baseline conditions.
- 1.4.4 The desk and field-based assessment involves the following key activities:
- Familiarisation with the landscape and visual resources of the area through site visits and fieldwork within which the Scheme would be located;
 - Identification of landscape and visual resources through site visits and fieldwork likely to be significantly affected by the Scheme;
 - Preparation of Zone of Theoretical Visibility (ZTV) maps;
 - Identification of the location of viewpoints, informed by site visits /fieldwork and the ZTV, that are used to inform the assessment of effects of both landscape and visual resources; and
 - Identification of suitable Study Areas for the LVIA.
- 1.4.5 Fieldwork is undertaken by a Chartered Landscape Architect, from a car, bicycle or on foot.

Landscape Baseline

- 1.4.6 The landscape baseline is established by undertaking a detailed desk study including a review of published Landscape Character Assessments, fieldwork, and analysis of findings to create a detailed understanding of the existing landscape context of the Solar PV Sites, Cable Route and surrounding landscape within the Study Area. The desk-based assessment begins with a review of legislation, policy and guidance including published landscape and townscape character assessments of the area and its wider context.
- 1.4.7 The baseline for assessing landscape effects addresses the effects of change and development on the landscape as a resource i.e.:

- The landscape components which contribute to the character of the landscape; for example topography, landcover, land use, vegetation, settlement and buildings;
- The aesthetic and perceptual aspects of the landscape;
- Landscape character and the key characteristics that contribute it.

Visual Baseline

- 1.4.8 The visual baseline establishes the areas from where the new components of the Scheme would be seen, who would see them, the places where those who would see them would be affected and the nature of views and visual amenity. Photography is used to record this.
- 1.4.9 This includes the identification of key receptors and viewpoints which represent such receptors. In order to assist with viewpoint selection and to appreciate the potential influence of the development in the wider landscape, preliminary ZTV plans may be used. ZTV plans illustrate the area from where it may be theoretically possible to view all, or part, of the Scheme. Viewpoints are illustrated on a plan and accompanied by a photographic record.
- 1.4.10 The visual assessment aims to determine from which points the Scheme can be seen in the surrounding landscape; this is known as the visual envelope. Once determined, a series of key representative viewpoints are chosen (i.e. areas within the visual envelope from where it may be possible to see the Scheme from publicly accessible locations), such as residential areas, public open spaces, PRow / public footpaths and roads.
- 1.4.11 Viewpoints identified through consultation and during desk studies are ground-truthed through fieldwork and their positions fixed prior to photography being undertaken. Landscape character types (LCTs) are reviewed during fieldwork and the descriptions contained in the published landscape character assessment are augmented where necessary. Landscape and visual receptors are also assessed to ensure they are accurately represented through desk-based assessment.
- 1.4.12 The baseline for assessing visual effects establishes the area from which Scheme may be visible and the nature and number of different groups of people (receptors) who are likely to experience change. For assessing visual effects, the receptors may include:
- Users of properties: such as residents, employees or visitors;
 - Users of public rights of way: public footpaths, bridleways, byways and permissive paths;
 - Users of transport routes: main roads and residential streets; and

- Users of places accessible to the public including open space areas, gardens and other destinations.

1.5 Approach to Mitigation

- 1.5.1 In accordance with the EIA Regulations, mitigation measures proposed to prevent/avoid, reduce and where practicable offset or remedy (or compensate for) any significant adverse landscape and visual effects are described. The LVIA takes the following approach to the mitigation hierarchy and what is required in the process of assessment of both the landscape and visual effects.
- 1.5.2 Mitigation measures are considered to fall into the categories of: Embedded mitigation, developed through the iterative design process and integrated or embedded into the project design; standard construction and operational management practices; and additional mitigation, specifically intended to address significant residual adverse effects but not built into the design of the Scheme.

Avoidance Measures

- 1.5.3 Avoidance is the first step of the mitigation hierarchy which comprises measures taken to avoid creating impacts from the outset, such as careful spatial placement of infrastructure, or timing construction sensitively to avoid disturbance. These measures are incorporated into the design of the scheme to avoid development impacts and control any negative effects on the landscape. This is particularly important where sensitive receptors are identified or when the Scheme is in or near to a highly valued and/or designated landscape.

Embedded Mitigation

- 1.5.4 Paragraph 4.21 to 4.27 of GLVIA3 describes the approach to the mitigation hierarchy of landscape and visual effects. In line with this, the LVIA process would ensure that through an iterative design process the design of the scheme and mitigation occurs in parallel with the EIA process through consideration of the various stages of an EIA including:
- 1.5.5 Embedded mitigation is informed by the following;
- Feasibility;
 - Scoping;
 - Post scoping – scoping opinion;
 - Co design initial consultation;
 - Design evolution;
 - Statutory consultation;

- Post consultation design refinement; and
- Detailed Design and optimisation.

- 1.5.6 The approach combines assessment, defines parameters, provides refinement and mitigation; together with an integrated approach to environmental constraints and consultation responses. This would ensure that the final design would embed mitigation in an integrated way to reduce any potential significant effects from the Scheme on identified receptors.
- 1.5.7 Embedded mitigation forms an integral, committed and deliverable part of the Scheme design and can also comprise standard construction practices. They are assumed to be implemented and are therefore factored into the assessment process. Embedded mitigation is taken into account during the construction, operation (Year 1 and Year 15) and decommissioning stages of the Scheme.
- 1.5.8 The mitigation measures are iterative and modify the scale and layout of the Scheme and also strive to achieve acceptability in terms of planning policy compliance. Embedded mitigation can include modifications to siting, access, layout, buildings, structures, ground modelling and landscaping (including conservation of existing vegetation and new planting). These measures aim to ensure a reasonable balance of viability and to meet with policy expectations and importantly must be deliverable.
- 1.5.9 It is expected that these measures would be implemented as they are to be an integral part of the Scheme. They would be secured by conditions (known as Requirements) on a consent.
- 1.5.10 A detailed list of examples of embedded mitigation considered in the LVIA which may mitigate or reduce the effects of the scheme is provided in the table below:

Table.8.1.1.1: Examples of Embedded Mitigation

Initial Assessment	<p>Information obtained from work undertaken as part of the desk based and feasibility assessment that informs the design process.</p> <p>Information obtained from an assessment and understanding of the Solar PV Sites and Cable Route from initial site visit and scoping stage that informs the design process.</p> <p>Information gathered and observed through subsequent site visits undertaken during the ES process including an understanding of the key characteristic features of the Solar PV Sites, Cable Route and surrounding landscape character.</p> <p>Undertaking of an initial high level parameters plan based on OS and GIS data sets and inclusions of information from site visits and surveys by the landscape architect and other consultants.</p> <p>Consultation through non statutory Co:Design workshops and statutory consultation as part of the DCO process.</p> <p>Undertaking of detailed parameters planning based on topographical survey data and integrating data from other disciplines such as ecology, arboriculture, archaeology, heritage, glint and glare, transport, flood risk and drainage, acoustics noise,</p>
---------------------------	--

	<p>and vibration, and agricultural land value (not exhaustive). This data will be available at various stages of the design evolution and detailed information is collated throughout the process until the scheme design is fixed. These parameters will be used to develop and ultimately fix the layout whilst providing sufficient areas for any proposed mitigation to be capable of being implemented and in terms of planting maturing to the desired height, width and function.</p> <p>Detailed design and assessment through the LVIA which informs the siting of the development, its design and likely materials would be undertaken in line with the above and would be subject to final design refinement prior to design fix.</p>
<p>Design</p>	<p>Preparation of Parameters which define the location of the solar panels and Associated Development, their spatial arrangement in the landscape and materials associated with the development including transformers and sub stations.</p> <p>Retention of natural features of the Solar PV Sites, Cable Route and surrounding landscape such as topography, watercourses, designations both statutory and non-statutory, woodland and vegetation, hedgerows.</p> <p>Retention of existing structures and buildings.</p>
<p>Mitigation</p>	<p>Retention of Existing features</p> <p>Gapping up of existing hedgerows and supplementary woodland/vegetation planting, changes to management of hedgerows and woodland/vegetation to improve quality, height, width or to ensure the existing features are suitable for long term mitigation and management associated with the mitigation requirements of landscape and visual receptors.</p> <p>Restoration or retention of existing earthworks.</p> <p>Restoration or retention of existing boundary structures/features such as fencing, walls, earth mounds.</p> <p>Restoration of historic hedgerows and woodland/vegetation in the landscape.</p> <p>New Planting</p> <p>Planting of new hedgerows, woodlands, shelterbelts, scrub, individual trees and vertical/woody vegetation aligned to landscape character.</p> <p>Planting of wildflowers and grassland to improve the overall landcover associated with solar farms and any other landscape features required for mitigation of effects at construction, year 1, and year 15 and decommissioning.</p> <p>Forward planting that may be required to mitigate effects.</p> <p>Proposed earthworks associated with the screening of components of the scheme.</p> <p>Proposed boundary structures/features such as fencing, walls, earth mounds to screen development.</p> <p>Measures for the management of vegetation at year 15 post construction or at decommissioning stages to ensure that the management of the mitigation and its establishment is adequate. This provides a robust response in relation to pressures on embedded mitigation such as planting for example as a result of climate change and growing prevalence of arboreal diseases and changing landscape character.</p>

Construction and Management controls	<p>Construction and Environmental Management Plan (CEMP) would control the construction process to ensure appropriate practices are followed to enable the above to be secured.</p> <p>Landscape and Environmental Management Plan (LEMP) would control how mitigation is implemented and managed to achieve the outcomes relied upon in the LVIA and as part of the DCO.</p> <p>The above documents would be subject to a DCO Requirement ensuring their delivery.</p>
---	---

- 1.5.11 The above shows examples of the LVIA approach to embedded mitigation to ensure the LVIA responds as sensitively as practicable to the landscape and visual resources on the Solar PV Sites, Cable Route and in the surrounding landscape.
- 1.5.12 The embedded mitigation would provide the best practicable fit of the Scheme within the landscape and consequently in views of the landscape from receptors being assessed.

Enhancement

- 1.5.13 Where relevant, enhancement measures are identified. Enhancement measures are not required to mitigate significant effects of the Scheme, as any measures required to achieve this will form part of the embedded mitigation identified as part of the iterative design process and will be assessed accordingly. Enhancement measures are therefore also not factored into the determination of residual effects. They are further measures which would have additional beneficial outcomes should they be implemented, but which are not required as a result of applying the mitigation hierarchy. Examples of enhancement measures may be improvements to the local Public Rights of Way (PRoW) network such as footpath improvements, bridges, gates or stiles; interpretation boards; community orchards for example and are usually derived through the consultation process. They may also form part of embedded *ecological* mitigation, for example but not contribute to a reduction in landscape or visual effects.
- 1.5.14 In designated or protected landscapes such as National Parks and National Landscapes there is a duty to 'further the purpose' of protected landscapes to conserve and enhance its natural beauty, as required by the LURA Act 2023¹. It is advised that measures that further the purposes are required over and above mitigation measures and should align with Management Plan objectives, principles and policies. However, in landscape proposals it is difficult to define the difference between landscape mitigation from landscape enhancement, for

¹ Levelling-up and Regeneration Act 2023 (LURA 2023) - Section 245 (Protected Landscapes)

example: a proposed new hedgerow can mitigate the visual effects of a development and provide positive enhancement to landscape character.

Additional Mitigation

- 1.5.15 Additional mitigation is that over and above the embedded mitigation that may be required and has the potential to mitigate any significant adverse effects identified following the assessment of the Scheme inclusive of its embedded mitigation.
- 1.5.16 Additional mitigation measures are those that are not built into the final design of the Scheme and are considered in relation to the assessment of the landscape and visual effects of the Scheme as the means of addressing the significant adverse effects identified.
- 1.5.17 As additional mitigation measures are not incorporated in the Scheme being assessed, there will need to be careful consideration of how they can be secured. In an ideal world, applying Landscape and Visual Impact Assessment as an iterative planning and design tool would allow all necessary and desirable mitigation to be embedded into the project design, such that additional mitigation should not prove necessary.
- 1.5.18 Where significant effects remain, following the implementation of embedded mitigation and achievable further measures would lower the identified effect, the assessment shall identify what (if any) additional mitigation applicable and explain how this would be secured, for example via a specific DCO Requirement or via a management plan secured by a DCO Requirement such as the CEMP or LEMP. An example of such mitigation could be temporary fencing to reduce glint and glare for visual receptors until planting has established on the Solar PV Sites.

1.6 Assessment of Landscape Effects

Landscape Receptors

- 1.6.1 Landscape effects are assessed at construction, operation and maintenance and decommissioning phases of the Scheme on the identified landscape receptors.
- 1.6.2 Landscape receptors are those parts of the receiving landscape that may be affected by the change. In LVIA identification of landscape receptors includes both:
- the constituent elements of the landscape (the Landscape Fabric) being the individual tangible elements or features of the landscape, such as landform, woodland, hedges, tree cover, vegetation within the development area or site, for example which can usually be described and quantified, and

- the specific aesthetic or perceptual qualities and the character of the landscape as a whole in different areas; and

1.6.3 As such, the Landscape Fabric of the Site is considered as a landscape receptor which is assessed separately to relevant Landscape Character Areas.

Assessing Landscape Sensitivity

1.6.4 The sensitivity of landscape receptors is assessed through consideration of their value and susceptibility to change. The process for determining landscape sensitivity is set out below.

Landscape Value

1.6.5 For landscape receptors, value concerns the importance of the landscape resource as evidenced by the presence of landscape designations and professional judgement. Susceptibility is concerned with the landscape's ability to absorb change brought about by the Scheme.

1.6.6 The European Landscape Convention (Ref.9) promotes the need to take account of all landscapes, with less emphasis on the special and more recognition that ordinary landscapes, such as community landscapes also have their own value. GLVIA3 paragraph 5.19 also recognises that relative value is attached to different landscapes and states that *“value can apply to areas of landscape as a whole, or to individual elements, features and aesthetic or perceptual dimensions which contribute to the character of the landscape.”* And that *“the value attached to undesignated landscapes also needs to be carefully considered and individual elements of the landscape – such as trees, buildings or hedgerows – may also have value.”*

1.6.7 To assess the value attached to undesignated landscapes, criteria are set out within the Landscape Institute Technical Guidance Note 02/21 (TGN 02/21) (Table A2.15 2020) (Ref.10).

1.6.8 **Table 8.1.1.2** illustrates the selection of criterion used for assessing the value of undesignated landscapes within TGN 02/21.

Table 8.1.1.2: Criterion for Assessing the Value of Undesignated Landscapes

Factor	Definition	Examples of evidence
Natural heritage	Landscape with clear evidence of ecological, geological, geomorphological or physiographic interest which	Landscape character assessment. LANDMAP Geological Landscape and Landscape Habitats Aspects (in Wales). Ecological and geological designations. SSSI citations and condition assessments. Geological Conservation Review. Habitat surveys.

Factor	Definition	Examples of evidence
	contribute positively to the landscape	Priority habitats. Nature recovery networks/ nature pathways. Habitat network opportunity mapping/ green infrastructure mapping. Catchment management plans. Ecosystem services assessment/ schemes. Specialist ecological studies.
Cultural heritage	Landscape with clear evidence of archaeological, historical or cultural interest which contribute positively to the landscape.	Landscape character assessment. LANDMAP Historic Landscape and Cultural Landscape Services Aspect (in Wales). Historic environment and archaeological designations. Conservation Area appraisals, Village Design Statements. Historic maps. Historic landscape character assessments, Historic Land Use Assessment and Historic Area Assessments. Place names. Specialist heritage studies.
Landscape condition	Landscape which is in a good physical state both with regard to individual elements and overall landscape structure.	Landscape character assessment. LANDMAP condition and trend questions (in Wales). Hedgerow/ tree surveys. Observations about intactness/ condition made in the field by the assessor. SSSI condition assessments. Historic landscape character assessments/ map regression analysis.
Associations	Landscape which is connected with notable people, events and the arts	Information about arts and science relating to a place. Historical accounts, cultural traditions and folklore. Guidebooks/ published cultural trails. LANDMAP Cultural Landscape Services aspect (in Wales).
Distinctiveness	Landscape that has a strong sense of identity	Landscape character assessment. LANDMAP Visual & Sensory question 3 and 25, – Historic Landscape question 4 (in Wales). Guidebooks Observations about identity/ distinctiveness made in the field by the assessor.
Recreational	Landscape offering recreational opportunities where experience of landscape is important	Definitive public rights of way mapping/ OS map data. National Trails, long distance trails, Coastal Paths, Core Paths. Open access land (including registered common land).

Factor	Definition	Examples of evidence
		Database of registered town or village greens Visitor surveys/ studies. Observations about recreational use/ enjoyment made in the field by the assessor.
Perceptual (Scenic)	Landscape that appeals to the senses, primarily the visual sense	Landscape character assessment LANDMAP Visual and Sensory scenic quality question 46 (in Wales). Protected views, views studies. Areas frequently photographed or used in images used for tourism/ visitor/ promotional purposes, or views described or praised in literature. Observations about scenic qualities made in the field by the assessor. Conservation Area Appraisals Village Design Statements, or similar.
Perceptual (Wildness and tranquillity)	Landscape with a strong perceptual value notably wildness, tranquillity and/or dark skies	Tranquillity mapping and factors which contribute to and detract from tranquillity. Dark Skies mapping. Wildness mapping, and Wild Land Areas in Scotland. Land cover mapping. Field survey LANDMAP. Visual and Sensory Aspect.
Functional	Landscape which performs a clearly identifiable and valuable function, particularly in the healthy functioning of the landscape	Land cover and habitat maps. Ecosystem services assessments and mapping (particularly supporting and regulating services). Green infrastructure studies/strategies. Development and management plans for nationally-designated landscapes, Local Plans and SPDs. Landscape character assessments.

Landscape Receptor Value

1.6.9 **Table 8.1.1.3** below illustrates the criteria for determining the value of the identified landscape receptors.

Table 8.1.1.3: Landscape Receptor Value

Landscape Value	Recognition	Features / Quality	Condition
High	Typically, a landscape / feature of international or national recognition e.g., World Heritage Sites, National Landscapes, National Parks, Scheduled	A strong sense of place with landscape / features worthy of conservation; absence of detracting features.	A high-quality landscape / feature; attractive landscape / feature; exceptional landscape with a strong strength of character.

Landscape Value	Recognition	Features / Quality	Condition
	Monuments and Grade I and II* Listed Buildings, Registered Parks and Gardens		
Medium	Regional recognition e.g., Conservation Areas; Grade II Listed Buildings, Registered Parks and Gardens	A number of well distinguished features worthy of conservation; evidence of some degradation and occasional detracting features.	A good quality landscape / feature with some potential for substitution; a reasonably attractive landscape / feature.
Low	Undesignated, but locally valued landscape / features	Few landscape features worthy of conservation; evidence of degradation with some detracting features.	An ordinary landscape / feature with high potential for substitution; quality that is fairly commonplace.
Very Low	Typically, an undesignated landscape / feature.	No landscape features worthy of conservation; evidence of degradation with many detracting features.	Very low quality landscape / feature with very high potential for substitution; limited variety or distinctiveness; commonplace.

Susceptibility of the Landscape Receptors to Change

1.6.10 This means the ability of the landscape receptor (whether it be the overall character or quality/condition of a particular landscape type or area, or an individual element and/or feature, or a particular aesthetic and perceptual aspect) to accommodate the Scheme without undue consequences for the maintenance of the baseline situation and/or the achievement of landscape planning policies and strategies (Ref.11).

1.6.11 **Table 8.1.1.4** below illustrates the criteria for determining the susceptibility to change of the identified landscape receptor:

Table 8.1.1.4: Landscape Receptor Susceptibility to Change

Landscape Susceptibility	Criterion
High	The landscape receptor is highly susceptible to the Scheme, and a low ability to accommodate the specific proposed change, because the key characteristics of the landscape have no or very limited ability to accommodate the specific proposed change without undue adverse effects taking account of the existing character and quality of the landscape, and/or achievement of relevant planning policies and strategies.

Landscape Susceptibility	Criterion
Medium	The landscape receptor is moderately susceptible to the Scheme, and a moderate ability to accommodate the specific proposed change, because the relevant characteristics of the landscape have some ability to accommodate it without undue adverse effects, taking account of the existing character and quality of the landscape, and/or achievement of relevant planning policies and strategies.
Low	The landscape receptor has low susceptibility to the Scheme, and a high ability to accommodate the specific proposed change, because the relevant characteristics of the landscape are generally able to accommodate it with little, or no, undue consequences for the maintenance of the baseline situation, taking account of the existing character and quality of the landscape.
Very Low	Very high ability to accommodate the specific proposed change; no undue consequences for the maintenance of the baseline situation (receptor value) and/or achievement of relevant planning policies and strategies.

Landscape Sensitivity

- 1.6.12 GLVIA3 (paragraph 5.39) indicates that combining susceptibility and value can be achieved in a number of ways and needs to include professional judgement. However, it is generally accepted that a combination of high susceptibility and high value is likely to result in the highest sensitivity, whereas a low susceptibility and low value is likely to result in the lowest level of sensitivity. It should be noted that the levels are indicative and in practice there is not a clear distinction between criteria levels.
- 1.6.13 **Table 8.1.1.5** provides a summary of the likely characteristics of the differing levels of sensitivity of the landscape receptor.

Table 8.1.1.5: Landscape Receptor Sensitivity Criterion

Landscape Sensitivity	Characteristics
High	Landscape character, characteristics, and elements where, through consideration of the landscape resource and characteristics, there would generally be a lower landscape tolerance or scope for landscape change or positive enhancement, and higher landscape value and quality. Often includes landscapes which are highly valued for their scenic quality, including most statutorily (nationally / internationally designated landscapes). Elements/features that could for example be described as unique or are nationally scarce. Mature vegetation with provenance such as ancient woodland or mature parkland trees, and/or mature landscape features which are characteristic of and contribute to a sense of place and illustrates time- depth in a

Landscape Sensitivity	Characteristics
	landscape and if replaceable, would for example not be replaced other than in the long term.
Medium	<p>Landscape character, characteristics, and elements where, through consideration of the landscape resource and characteristics, there would be a medium landscape tolerance or some scope for landscape change. Often includes landscapes of medium landscape value and quality which may be locally designated.</p> <p>Areas that have a positive landscape character but include some areas of alteration/degradation/or erosion of features.</p> <p>Perceptual/aesthetic aspect has some vulnerability to unsympathetic development; and/or features/elements that are locally commonplace; unusual locally but in moderate/poor condition; or mature vegetation that is in moderate/poor condition or readily replicated.</p>
Low	<p>Landscape character, characteristics, and elements where, through consideration of the landscape resource and characteristics, there would be higher landscape tolerance or scope for landscape change or positive enhancement.</p> <p>Damaged or substantially modified landscapes with few characteristic features of value.</p> <p>Capable of absorbing major change, and landscape elements/features that might be considered to detract from landscape character such as obtrusive man-made features.</p>
Very Low	<p>Landscape character, characteristics, and elements where there is a high landscape tolerance or a planned desire for landscape change. Usually applies to landscapes with a lower landscape susceptibility or higher landscape tolerance for the Scheme. May also apply to derelict landscapes, spoil heaps, and de-graded urban fringe areas that require restoration or re- development / re-planting.</p> <p>Areas that are relatively bland or neutral in character with few/no notable features.</p> <p>A landscape that includes areas of alteration/degradation or erosion of features, and/or landscape elements/features that are commonplace or make little contribution to local distinctiveness.</p> <p>Opportunities for the restoration of landscape through mitigation measures associated with the proposal.</p>

1.6.14 The judgement on landscape sensitivity as explained above is based on consideration of both the landscape receptor's value and its susceptibility to change arising from the Scheme.

1.6.15 **Table 8.1.1.6** below illustrates how landscape value and susceptibility are combined to determine the level of landscape sensitivity.

Table 8.1.1.6: Matrix for Determining Landscape Sensitivity

Landscape Susceptibility	High	Medium	Low	Very Low
Landscape Value				
High	High	High to Medium	Medium	Medium to Low
Medium	High to Medium	Medium	Medium to Low	Low
Low	Medium	Medium to Low	Low	Low to Very Low
Very Low	Medium to Low	Low	Low to Very Low	Very Low

Magnitude of Landscape Change

1.6.16 The determination of the magnitude of landscape change combines an assessment of the size or scale of change likely to be experienced as a result of each effect (Ref.12), the geographical extent of the area likely to be influenced and the duration and reversibility of effects.

Size or Scale

1.6.17 Judgements are needed about the size or scale of change in the landscape that is likely to be experienced as a result of each effect. GLVIA3 (paragraph 5.49), states that “*The judgements should, for example, take account of:*

- *The extent of the existing landscape elements that would be lost, the proportion of the total extent that this represents and the contribution of that element to the character of the landscape – in some cases this may be quantified;*
- *The degree to which aesthetic and perceptual aspects of the landscape are altered either for example, removal of existing components of the landscape or by addition of new ones – for example, removal of hedges may change a small scale, intimate landscape into a large-scale, open one, or introduction of new buildings or tall structures may alter open skylines;*
- *Whether the effects change the key characteristics of the landscape, which are critical to its distinctive character.”*

Geographical Extent

1.6.18 The geographical area over which the landscape change would be experienced is also considered. This is dependent upon the nature of the proposal and the scale of effects upon the receiving landscape/landscapes; however, GLVIA3 (paragraph 5.50), notes that, in general effects may have an influence at

varying scales and states that *“this will vary according to the nature of the project and may not always be relevant on every occasion:*

- *at the site level, within the proposed development site itself;*
- *at the level of the immediate setting of the site;*
- *at the scale of the landscape type or character area within which the proposal lies;*
- *on a larger scale, influencing several landscape types or character areas.”*

Duration and Reversibility of the Landscape Effects

1.6.19 GLVIA3 (paragraph 5.51), notes that duration and reversibility are separate but linked considerations. Duration can usually be simply judged on a scale such as:

- Short-term: 0-5 years;
- Medium- term: 5-10 years;
- Long-term: 10-40 years (or longer).

1.6.20 Reversibility is a judgement about whether or not the Scheme can be removed, and once removed whether the landscape can be reinstated and/or fully restored. GLVIA3 notes at paragraph 5.52 that *“Mineral workings may be partially reversible in that the landscape can be restored to something similar to, but not the same as, the original...Duration and reversibility can sometimes usefully be considered together, so that a temporary or partially reversible effect is linked to definition of how long that effect will last”.*

1.6.21 **Table 8.1.1.7** below indicates the type of land use and the respective assessment of reversibility defined by GLVIA3 (paragraph 6.41).

Table 8.1.1.7: Magnitude of Landscape Change: Duration and Reversibility

Category	Description
Permanent	Permanent, is irreversible change to the landscape, such as housing development, as it not possible to remove such a development and restore the land to the original state.
Partially Reversible	Partially Reversible, is change to the landscape, where the landscape can be restored to something similar to the landscape that was removed. For example, mineral developments, as it is possible to restore the land to something similar to the original state, but not the same state.
Reversible	Reversible, is change to the landscape where the landscape can be fully restored. For example, a marine fish farm development, as it is possible to wholly remove such a development and to restore the landscape to the original state. This also includes construction activities which are of temporary nature.

- 1.6.22 It is clarified within LITGN-2024-01 (Ref.5) that *“for magnitude of change, it is likely that the size/scale of effect will be the most important factor, with geographical extent and duration/ reversibility considered as ‘modifiers’. When taking account of geographic extent and duration, care should be taken to ensure that the resulting magnitude of effect judgement is not understated. The focus should be on what would be affected and where, not restricted to the proportion of a landscape character area or designated area affected.”*(Clarification note 3(3)).
- 1.6.23 Clarification note 5(11) explains *“geographical extent should reflect the relevance of the location (for example it may more strongly or weakly manifest one of the key characteristics than other areas, or it may have a geographic role in connecting parts of the receptor) and the spread of effects, as a ‘modifier’ to the scale of effect so that it does not understate the magnitude of effects for extensive receptors such as large character areas or designations.*

Overall Magnitude of Landscape Change

- 1.6.24 The overall magnitude of landscape change combines size and scale, geographical extent and duration and reversibility. Not all aspects of a criterion need to be met for an evaluation to be given.
- 1.6.25 **Table 8.1.1.8** below sets out the criterion used to assess the overall magnitude of landscape change.

Table 8.1.1.8: Overall Magnitude of Landscape Change

Magnitude Evaluation	Size, scale and nature	Geographical Extent	Duration & Reversibility
High	<p>A large extent of existing landscape elements would be lost / adjusted, the proportion that this represents within the landscape is considerable and the resultant change to the landscape character resulting from such a loss is large.</p> <p>Large scale alteration of the aesthetic and perceptual aspects of the landscape such as the removal of existing components of the landscape or by addition of new ones – for example, removal of hedges may change a small scale, intimate landscape into a large-scale, open one, or introduction of new buildings</p>	<p>The change would affect all of the landscape receptors being assessed, as the Scheme would occupy a large geographical extent, e.g., the change would be on a large scale, influencing several landscape types or character areas.</p>	<p>Long term; permanent / non-reversible or partially reversible.</p>

Magnitude Evaluation	Size, scale and nature	Geographical Extent	Duration & Reversibility
	<p>or tall structures may alter open skylines.</p> <p>The effects change the key characteristics of the landscape features and landscape character, which are critical to its distinctive overall character.</p>		
Medium	<p>A medium extent of existing landscape elements would be lost / adjusted, the proportion that this represents within the landscape is medium and the resultant change to the landscape character resulting from such a loss is medium.</p> <p>Medium scale alteration of the aesthetic and perceptual aspects of the landscape such as the removal of existing components of the landscape or by addition of new ones.</p> <p>The effects change some of the key characteristics of the landscape features and landscape character, which are critical to its distinctive overall character.</p>	<p>The change would affect a medium extent of the landscape receptors being assessed, as the Scheme would occupy a moderate geographical extent, e.g., at the scale of the landscape type or character area within which the proposal lies.</p>	<p>Medium term; semi- permanent or partially reversible.</p>
Low	<p>A small extent of existing landscape elements would be lost / adjusted, the proportion that this represents within the landscape is low and the resultant change to the landscape character resulting from such a loss is low.</p> <p>Small scale alteration of the aesthetic and perceptual aspects of the landscape such as the removal of existing components of the landscape or by addition of new ones.</p> <p>The effects change a small number of the key characteristics of the landscape features and</p>	<p>The change would affect a small part of the landscape receptors being assessed, as the Scheme would occupy a small geographical extent, e.g., at the level of the immediate setting of the Scheme.</p>	<p>Short term / temporary; partially reversible or reversible.</p>

Magnitude Evaluation	Size, scale and nature	Geographical Extent	Duration & Reversibility
	landscape character, which are critical to its distinctive overall character.		
Very Low	<p>A barely perceptible extent of landscape features and elements of importance to the character of the baseline are lost / adjusted.</p> <p>There is a barely discernible change to aesthetic and / or perceptual attributes of landscape features and landscape character and such changes occur across a very limited geographical area and / or proportion of the landscape receptor.</p> <p>The effects change a barely discernible number of the key characteristics of the landscape, which are critical to its distinctive character.</p>	The change would affect only a negligible part of the landscape receptors being assessed, as the Scheme would occupy a limited geographical extent, e.g., the site level, within the Scheme itself.	Short term / temporary; partially reversible or reversible.

1.7 Assessment of Visual Effects

Visual Receptors

1.7.1 Visual effects are assessed at construction, operation and maintenance and decommissioning phases of the Scheme on the identified visual receptors.

1.7.2 Visual receptors are the people able to view the proposal, that may be affected by changes in views or visual amenity at different places.

1.7.3 Visual effects relate to changes in available views of the landscape and the effect of those changes on people, including:

- The direct effects of the Scheme on the content and character of views through the intrusion or obstruction and/or the change or loss of existing elements.
- The overall effect on visual amenity, be it degradation or enhancement.

1.7.4 Visual effects are concerned with the effect of the Scheme on views, and the general visual amenity of users and are defined by the Landscape Institute in GLVIA 3 (paragraph 6.1), as follows:

“An assessment of visual effects deals with the effects of change and development on views available to people and their visual amenity. The concern

... is with assessing how the surroundings of individuals or groups of people may be specifically affected by changes in the context and character of views.”

- 1.7.5 Visual effects are identified for different receptors (people) who will experience the view at their places of residence, during recreational activities, at work, or when travelling through the area. The visual effects may include the following:
- Visual effect: a change to an existing static view, sequential views, or wider visual amenity as a result of the Scheme, or
 - the loss of particular landscape elements or features already present in the view.
- 1.7.6 The visual assessment for the LVIA process aims to determine from which points the Scheme can be seen in the surrounding landscape; this is known as the visual envelope. Once determined, a series of representative, specific and illustrative viewpoints are chosen (i.e., areas within the visual envelope from where it may be possible to see the Scheme from publicly accessible viewpoints), such as residential areas, public open spaces, PRow / public footpaths and roads.
- 1.7.7 Visual effects relate to changes in available views of the landscape and the effect of those changes on people, including:
- The direct effects of the Scheme on the content and character of views through the intrusion or obstruction and/or the change or loss of existing elements.
 - The overall effect on visual amenity, be it degradation or enhancement.
- 1.7.8 In predicting the effects of the Scheme on the visual receptors from the viewpoints being assessed, GLVIA3 (para 6.27), states that it is helpful to consider (but not restricted to) the following factors:
- Nature of the view (full, partial or glimpsed);
 - Proportion of the Scheme visible (full, most, part or none);
 - Distance of the viewpoint from the Scheme and whether it would be the focus of the view or only a small element;
 - Whether the view is stationary, transient, or sequential; and
 - The nature of the changes to the view.
- 1.7.9 Additionally, the seasonal effects of vegetation are considered, in particular the varying degree of screening and filtering of views.
- 1.7.10 People have different responses to views which are dependent upon context such as the:

- Location;
- Time of day;
- Season; and
- Degree of exposure to views.

1.7.11 Responses to views are also dependent upon the purpose of people being in a particular place such as:

- Recreation;
- Residence;
- Employment; and
- Passing through on roads, rail, or other forms of transport.

1.7.12 As people move through the landscape, certain activities or locations may be specifically associated with the experience and enjoyment of the landscape, such as:

- The use of paths such as footpaths, bridleways, byways open to all traffic (BOATs) and National Trails;
- National or local cycle routes; and
- Tourist or scenic routes, and associated viewpoints on land or water.

Assessing Visual Sensitivity

1.7.13 To determine visual effects, both the sensitivity of the visual receptor and the magnitude of change are considered. Determining visual sensitivity is the combination of susceptibility to change and value of a view. It is considered that a combination of high susceptibility to change and high value of a view is likely to result in the highest sensitivity, whereas a low susceptibility and low value of a view is likely to result in the lowest level. The value, susceptibility to change and resultant sensitivity of a visual receptor are categorised based on the following **Tables 8.1.1.9 to 8.1.1.12**. It should be noted that the levels are indicative and in practice there is not a clear distinction between criteria levels.

1.7.14 The susceptibility of visual receptors to changes in the view and visual amenity is related to activity they are engaged in and the extent to which their attention is focussed on the views and visual amenity at that location. As such, those receptors most sensitive to change are likely to include people engaged in outdoor activities where an appreciation of the landscape is the focus or residents in areas where the landscape setting contributes to the setting of the properties.

- 1.7.15 Conversely, those considered least sensitive to change include (but are not restricted to) people engaged in outdoor sports or recreation where there is no focus on the surrounding landscape/views and people at their place of work where the focus is on the work activity.

Value of Views

- 1.7.16 The value attached to views is judged based on the following factors:
- Recognition of the value attached to particular views, for example in relation to heritage assets, or through planning designations; and
 - Indicators of the value attached to views by visitors, for example through appearances in guidebooks or on tourist maps, provision of facilities for their enjoyment and references to them in literature or art.
- 1.7.17 **Table 8.1.1.9** summarises the criterion used to assess the value attached to views.

Table 8.1.1.9: Value Attached to Views

Visual Value	Criterion
High	Views from and within landscapes / viewpoints of national importance (National Parks, AONBs), highly popular visitor attractions where the view forms an important part of the experience, or heritage assets, or through planning designations such as conservation areas, listed buildings, Registered Parks & Gardens, or with important cultural associations, or where the view is deemed by the assessor to be of a high value.
Medium	Views from landscapes / viewpoints of regional/district importance, or visitor attractions at regional or local levels where the view forms part of the experience, or local planning designations, or with local cultural associations, or where the view is deemed by the assessor to be of a medium value.
Low	Views from landscapes / viewpoints with no designations, and not particularly popular as a viewpoint, and unlikely to be visited specifically to experience the view available, with minimal or no cultural associations, or where the view is deemed by the assessor to be of a low value.
Very Low	Views from landscapes / viewpoints with no designations, and not popular as a viewpoint, and where view provides no positive contribution to the appreciation of the landscape with no cultural associations, or where the view is deemed by the assessor to be of very low value.

Table 8.1.1.10: Visual Receptor Susceptibility to Change

Visual Susceptibility	Type of Receptor
High	<p>Residents at home.</p> <p>Views from well used public rights of way including strategic footpaths / long distance trails and cycle routes (where the attractive nature of the countryside is a significant factor in the enjoyment of the walk).</p> <p>Visitors along scenic routes and to recognised viewpoints.</p> <p>Visitors to protected landscapes or heritage assets where views of the surroundings are an important contributor to the experience.</p> <p>The location, numbers, frequency of use and visual context of the viewpoint would be high.</p> <p>Communities where views contribute to the landscape setting enjoyed by residents in the area.</p> <p>Travellers on road, rail, or other transport routes along scenic routes, where the appreciation of the view contributes to the enjoyment and quality of the journey.</p>
Medium	<p>Views experienced from boats, public rights of way / footpaths used locally and passing through the landscape and well used footpaths within settlements.</p> <p>Views from places of worship and associated grounds, schools, country parks and golf clubs.</p> <p>Views experienced by users of local roads where there are clear / open views across the landscape and low levels of traffic.</p> <p>The location, numbers, frequency of use and visual context of the viewpoint would be medium.</p>
Low	<p>Views experienced from places of work where workers and visitors are concentrating on their day-to-day activities.</p> <p>Views experienced by or near to motorways or major roads.</p> <p>Views experienced by users of the rail network and main roads travelling at speed or local roads where the focus is upon the road ahead owing to traffic conditions and the context / composition of the view.</p> <p>Views experienced from less well used public rights of way which pass through less attractive landscapes or townscapes and are not used for enjoyment of the scenery.</p> <p>Views experienced by those playing or spectating at outdoor sports or utilising outdoor sports facilities.</p> <p>The location, numbers, frequency of use and visual context of the viewpoint would be low.</p>
Very Low	<p>Views experienced from places of work where workers and visitors are concentrating on their day-to-day activities.</p> <p>Views experienced by or near to motorways or major roads.</p> <p>Views experienced by users of the rail network and main roads travelling at high speed or local roads where the focus is upon the road ahead owing to traffic conditions and the context / composition of the view.</p>

Visual Susceptibility	Type of Receptor
	<p>Views experienced from very infrequently used public rights of way which pass through unattractive or discordant landscapes or townscape and are not used for enjoyment of the scenery.</p> <p>Views experienced by those of which the view is unlikely to be part of the receptor's experience.</p> <p>The location, numbers, frequency of use and visual context of the viewpoint would be very low.</p>

Sensitivity of Visual Receptors

- 1.7.18 The sensitivity of visual receptors is defined in terms of the relationship between the value of views and the susceptibility of the different viewers to the proposed change. Professional judgements are made on the merit of the view based on the visual receptor. It should be noted that the levels are indicative and in practice there is not a clear distinction between criteria levels.
- 1.7.19 **Table 8.1.1.11** below summarises the likely characteristics of the differing levels of sensitivity.

Table 8.1.1.11: Visual Receptor Sensitivity Criterion

Visual Sensitivity	Characteristics
High	<p>A well-balanced view containing attractive features and notable for its scenic quality with no or very few/minimal visual detractors.</p> <p>A view which is an important reason for receptors being there.</p> <p>A view which is experienced by a large number of people and/ or recognised for its qualities.</p> <p>A view with a medium – high susceptibility to change and experienced by visual receptors of a high value.</p>
Medium	<p>An otherwise attractive view that includes some attractive or discordant features/visual detractors.</p> <p>A view which plays a part in the reason why a receptor would be there.</p> <p>A view which is locally recognised.</p> <p>A view with a low - medium susceptibility to change and experienced by visual receptors of a low - medium value.</p>
Low	<p>A view that is simplistic and contains few attractive or notable features or a number of visual detractors which may dominate the view.</p> <p>A view which plays a small part in the reason why a receptor would be there.</p> <p>A view with a low susceptibility to change, and a low value.</p>
Very Low	<p>A view that is unattractive, discordant and/or contains many visual detractors.</p> <p>A view which is unlikely to be part of the receptor's experience.</p> <p>A view with a very low susceptibility to change, and very low sensitivity.</p>

1.7.20 The judgement on visual sensitivity as explained above is based on consideration of both the visual receptor's value and its susceptibility to change arising from the Scheme.

1.7.21 **Table 8.1.1.12** illustrates how visual value and susceptibility are combined to determine the level of visual sensitivity.

Table 8.1.1.12: Matrix for Determining Visual Sensitivity

Visual Susceptibility	High	Medium	Low	Very Low
Visual Value				
High	High	High to Medium	Medium	Medium to Low
Medium	High to Medium	Medium	Medium to Low	Low
Low	Medium	Medium to Low	Low	Low to Very Low
Very Low	Medium to Low	Low	Low to Very Low	Very Low

Magnitude of Visual Change

1.7.22 The magnitude of change to visual receptors is assessed in terms of the following factors:

Size or Scale

- The scale of the change in the view with respect to the loss or addition of features in the view and changes in its composition, including the proportion of the view occupied by the Scheme;
- The degree of contrast or integration of any new features or changes in the landscape with the existing or remaining landscape elements and characteristics in terms of form, scale and mass, line, height, colour, and texture; and
- The nature of the view of the Scheme, in terms of the relative amount of time over which it would be experienced and whether views would be full, partial or glimpses.

1.7.23 Not all aspects of a criterion need to be met for an evaluation to be given.

Geographical Extent

1.7.24 The geographical extent of the visual change identified at viewpoints is assessed by reference to a combination of the ZTV and field work.

1.7.25 The following factors are considered:

- The angle of view in relation to the main activity of the receptor;
- The distance of the viewpoint from the Scheme; and
- The extent of the area over which the changes would be visible.

Duration and Reversibility of Visual Effects

- 1.7.26 The following terminology, which considers whether views would be permanent and irreversible or temporary and reversible, is used to describe the duration of the visual change at representative, specific and illustrative viewpoints:
- Short-term: 0-5 years;
 - Medium-term: 5-10 years; and
 - Long-term: 10 to 40 years (or longer).
- 1.7.27 For the purposes of the LVIA process, the operation phase of the Scheme is of long term duration and the construction and decommissioning phases of the Scheme are both of short term duration.
- 1.7.28 Reversibility is the judgement about whether or not the Scheme can be removed, and once removed whether the view can be fully restored.
- 1.7.29 It is clarified within LITGN-2024-01 that *“for magnitude of change, it is likely that the size/scale of effect will be the most important factor, with geographical extent and duration/ reversibility considered as ‘modifiers’. When taking account of geographic extent and duration, care should be taken to ensure that the resulting magnitude of effect judgement is not understated. The focus should be on what would be affected and where, not restricted to the proportion of a landscape character area or designated area affected.”*(Clarification note 3(3)).
- 1.7.30 Clarification note 6(8) explains, *“Geographical extent should reflect the relevance of the location and spread of effects, as a ‘modifier’ to the scale of effect so that it does not understate the magnitude of effects for extensive receptors such as people using long-distance footpaths. For example, in considering views from a long distance footpath it may be relevant to consider both the frequency of use of particular parts of the route and the degree to which visibility arises from those parts of the route. Open views of a development from long stretches of a more frequently used section would be expected to contribute to a greater extent (and magnitude) of effect than a glimpsed view from an overgrown section with little sign of recent use.”*

Overall Magnitude of Visual Change

- 1.7.31 **Table 8.1.1.13** below sets out the criterion used to assess the overall magnitude of visual change.

Table 8.1.1.13 Overall Magnitude of Visual Change

Magnitude Evaluation	Size, scale and nature	Geographical Extent	Duration & Reversibility
High	Occupies an extensive proportion of the view and may even obstruct a significant portion of the view. Views may become the dominant feature. Considerable change to the majority / many existing landscape elements and/or landscape character; fundamental changes the surroundings and baseline to a large extent; very noticeable.	Ranging from notable change over extensive area to intensive change over a more limited area.	Long term; permanent/ non-reversible or partially reversible.
Medium	Occupies much of the view but would not fundamentally change its characteristics. Changes would be immediately visible but not a key feature of the view. Some change to existing landscape elements and /or landscape character; discernible changes the surroundings of a receptor, such that its baseline is partly altered; readily noticeable.	Moderate changes in a localised area.	Medium term; semi-permanent or partially reversible.
Low	Occupies a small portion of the view and therefore would not result in a change to the view's composition. Small change to existing landscape elements and/or landscape character; slight, but detectable impacts that do not alter the baseline of the receptor materially not readily noticeable.	Minor changes in a localised area.	Short term / temporary; partially reversible or reversible.

Magnitude Evaluation	Size, scale and nature	Geographical Extent	Duration & Reversibility
Very Low	Occupies a small portion of the view and therefore would not result in a change to the view's composition. Small change to existing landscape elements and/or landscape character; slight, but detectable impacts that do not alter the baseline of the receptor materially not readily noticeable.	Minor changes in a localised area.	Short term / temporary; partially reversible or reversible.

1.8 Nature of Effects

1.8.1 The nature of an effect is also assessed. This is dependent on a number of criteria which vary between effects upon the landscape and effects on visual amenity. Effects are classified as beneficial, neutral, or adverse according to the following definitions:

- **Beneficial effects** contribute to the landscape and visual resource through the enhancement of desirable characteristics or the introduction of new, positive attributes. The removal of undesirable existing elements or characteristics can also be beneficial, as can their replacement with more appropriate components;
- **Neutral effects** occur where the Scheme neither contributes to nor detracts from the landscape and visual resource or where the effects are so limited that the change is hardly noticeable. A change to the landscape and visual resource is not considered to be adverse simply because it constitutes an alteration to the existing situation; and
- **Adverse effects** are those that detract from or weaken the landscape and visual resource through the introduction of elements that contrast in a detrimental way with the existing characteristics of the landscape and visual resource, or through the removal of elements that are key in its positive characterisation.

1.8.2 For the purpose of the LVIA, the process describes the overall effects on receptors and explains the justification for each assessment. For each assessed effect, a conclusion is drawn on whether the effect is beneficial, neutral, or adverse.

1.9 Significance of Effect and Criteria

1.9.1 The significance of landscape and visual effect and whether it is significant or not is assessed based on a combination of the sensitivity of the receptor and

the magnitude of change, alongside the professional judgement of a chartered landscape architect.

- 1.9.2 The combined sensitivity of the receptor and the magnitude of change is then used to determine the significance of effect. The nature of Landscape and Visual effects can be either beneficial, neutral, or adverse in nature.

Matrix of Combined Factors

- 1.9.3 **Table 8.1.1.14** below shows how the combined factors of sensitivity and magnitude are considered together to determine the significance of landscape and visual effects.

Table 8.1.1.14: Matrix for Determining Significance of Landscape and Visual Effects

Sensitivity	High	Medium	Low	Very Low
Magnitude				
High	Major	Major/ Moderate	Moderate	Moderate/Minor
Medium	Major/ Moderate	Moderate	Moderate/ Minor	Minor
Low	Moderate	Moderate/ Minor	Minor	Minor/ Negligible
Very Low	Moderate/ Minor	Minor	Minor/ Negligible	Negligible

- 1.9.4 In accordance with Infrastructure Planning (Environmental Impact Assessment) Regulations 2017, it is important to determine whether the predicted landscape and visual effects arising from the Scheme are likely to be significant.
- 1.9.5 Landscape and visual effects which result in a Major, Major/ Moderate, and Moderate landscape or visual effect are considered to be significant (see highlighted in grey in **Table 8.1.1.14** above).
- 1.9.6 Landscape and visual effects assessed as Moderate/Minor, Minor, Minor Negligible and Negligible are considered as not significant.

Categories of Effect

- 1.9.7 **Table 8.1.1.15** summarises the categories of landscape and visual effects.

Table 8.1.1.15: Categories of Landscape and Visual Effects

Significance of Effect	Description of Landscape Effects	Description of Visual Effects
Major	Considerable change over an extensive area of a highly sensitive landscape,	The Scheme would become a prominent feature and would result in a very

Significance of Effect	Description of Landscape Effects	Description of Visual Effects
	fundamentally affecting the key characteristics and the overall impression of its character.	noticeable change to an existing highly sensitive and well composed view.
Moderate	Small or noticeable change to a highly sensitive landscape or more intensive change to a landscape of medium or low sensitivity, affecting some key characteristics and the overall impression of its character.	The Scheme would introduce some enhancing or detracting features to an existing highly sensitive and well composed view or would be prominent within a less well composed and less sensitive view, resulting in a noticeable improvement or deterioration of the existing view.
Minor	Small change to a limited area of landscape of high or medium sensitivity or a more widespread area of a less sensitive landscape, affecting few characteristics without altering the overall impression of its character.	Where the Scheme would form a perceptible but not enhancing or detracting feature within a view of high or medium sensitivity or would be a more prominent feature within a poorly composed view of low sensitivity, resulting in a small improvement or deterioration of the existing view.
Negligible	No discernible improvement or deterioration to the existing landscape character.	No discernible improvement or deterioration in the existing view.
No Effect	Where there is a perceived or anticipated effect, but upon investigation non is found.	Where there is a perceived or anticipated effect, but upon investigation non is found.

Limitations of the assessment

- 1.9.8 It should be noted that this tabulated approach does not always result in a useful final assessment. Very noticeable changes for highly sensitive receptors will always result in major effects. If the changes are well designed and are appropriate to the context or replace inappropriate elements this will not necessarily be an adverse effect, but neither will it be a major beneficial effect. Where this is the case an assessment of the final effect is made according to professional judgement, and the reasons for the final effect identified will be provided.

2 Cumulative Assessment Methodology

2.1 Introduction

- 2.1.1 Assessment of cumulative effects is required both by the EIA and the Strategic Environmental Assessment (SEA) Directives and by the associated Regulations. Cumulative effects are defined in a broad generic sense as *‘impacts that result from incremental changes caused by other past, present or reasonably foreseeable actions together with the project’* (GLVIA3 paragraph 7.1).
- 2.1.2 GLVIA3 states that the key for all cumulative impact assessments is to focus on the likely significant effects and in particular those likely to influence decision making.
- 2.1.3 GLVIA3 defines cumulative effects and sets out that both cumulative landscape and cumulative visual effects must be considered in LVIA when it is carried out as part of EIA. In Scotland, considerable effort has been devoted to addressing definitions and interpretation around cumulative effects and the resulting guidance has been used widely, not only in Scotland, and so is considered relevant for this assessment. GLVIA3 (paragraph 7.3) defines cumulative effects as follows:
- **Cumulative effects** as *‘the additional changes caused by a proposed development in conjunction with other similar developments or as the combined effect of a set of developments, taken together’*
 - **Cumulative landscape effects** as effects that *‘can impact on either the physical fabric or character of the landscape, or any special values attached to it’*,
 - **Cumulative visual effects** as effects that *‘can be caused by combined visibility, which occurs where the observer is able to see two or more developments from one viewpoint and/or sequential effects which occur when the observer has to move to another viewpoint to see different developments’*
- 2.1.4 GLVIA3 states that:
- “It is always important to remember that the emphasis in EIA is on likely significant effects rather than on comprehensive cataloguing of every conceivable effect that might occur.”*
- 2.1.5 And that:
- “The emphasis must always be on the main project being assessed and how or whether it adds to or combines with the others being considered to create a **significant cumulative effect**”* [Author’s emphasis].

2.1.6 In most cases the focus of the cumulative assessment will be on the additional effect of the project in conjunction with other developments of the same type. In some cases, development of another type or types may be relevant and may help to give a more complete picture of the likely significant cumulative effects.

2.1.7 GLVIA3 sets out the timescale of proposals for inclusion within cumulative assessments.

“Taking ‘the project’ to mean the main proposal that is being assessed, it is considered that existing schemes and those which are under construction should be included in the baseline for both landscape and visual effects assessments (the LVIA baseline).”

“The baseline for assessing cumulative landscape and visual effects should then include those schemes considered in the LVIA and in addition potential schemes that are not yet present in the landscape but are at various stages in the development and consenting process:

- *schemes with planning consent; and*
- *schemes that are the subject of a valid planning application that has not yet been determined.*

Schemes that are at the pre-planning or scoping stage are not generally considered in the assessment of cumulative effects because firm information on which to base the assessment is not available and because of uncertainty about what will actually occur, that is, it is not ‘reasonably foreseeable’. But there may be occasions where such schemes may be included in the assessment if the competent authority or consultation bodies consider this to be necessary. Such a request should only be made if absolutely necessary to make a realistic assessment of potential cumulative effects.”

2.2 Types of Cumulative Effects

Landscape

2.2.1 Cumulative landscape effects may result from adding new types of change or from increasing or extending the effects of the main project when it is considered in isolation. For example, the landscape effects of the main project may be judged of relatively low significance when taken on their own, but when taken together with the effects of other development, usually of the same type, the cumulative landscape effects may become more significant. The key for all cumulative impact assessments is to focus on the likely significant effects and in particular those likely to influence decision making.

2.2.2 Cumulative landscape effects are likely to include effects:

- *on the fabric of the landscape as a result of removal of or changes in individual elements or features of the landscape and/or the introduction of new elements or features;*
- *on the aesthetic aspects of the landscape – for example its scale, sense of enclosure, diversity, pattern and colour, and/or on its perceptual or experiential attributes, such as a sense of naturalness, remoteness or tranquillity;*
- *on the overall character of the landscape as a result of changes in the landscape fabric and/or in aesthetic or perceptual aspects, leading to modification of key characteristics and possible creation of new landscape character if the changes are substantial enough.*

2.2.3 Cumulative landscape effects must be considered particularly in terms of consequences for the key characteristics of the landscape in question. The most significant cumulative landscape effects are likely to be those that would give rise to changes in the landscape character of the Study Area so as to result in significant effects on its key characteristics and even, in some cases, to transform it into a different landscape type.

Visual

2.2.4 Cumulative visual effects are the effects on views and visual amenity enjoyed by people, which may result either from adding the effects of the project being assessed to the effects of the other projects on the baseline conditions or from their combined effect. This may result from changes in the content and character of the views experienced in particular places due to introduction of new elements or removal of or damage to existing ones.

2.2.5 The distance between the visual receptors or viewpoints and the various projects does influence the magnitude of the cumulative visual effects and so feeds into judgements of their significance. Depending on the type of development it may be considered that more distant views are not likely to be significant.

2.2.6 As a number of separate developments must be considered, it is important to understand how these may be visually experienced.

2.2.7 At one viewpoint someone looking at the view in one direction may see all the projects at the same time, or someone turning through the whole 360 degrees may see different developments in different directions and sectors of the view in succession. This is referred to as combined visibility.

2.2.8 Users of linear routes, especially footpaths or other rights of way, or transport routes, may potentially see the different developments revealed in succession as a series of sequential views. This is referred to as sequential visibility.

2.2.9 Both types of experience are considered where they are relevant.

Combined Occurs when the observer is able to see two or more developments from one viewpoint.	In Combination	Where two or more developments are or would be within the observers' arc of vision at the same time without moving their head.
	In Succession	Where the features appear regularly and with short time lapses between instances depending on speed of travel and distance between the viewpoints.
Sequential Occurs when the observer has to move to another viewpoint to see the same or different developments. Sequential effects may be assessed for travel along regularly used routes such as major roads or popular paths.	Frequently sequential	Where the features appear regularly and with short time lapses between instances depending on speed of travel and distance between the viewpoints
	Occasionally sequential	Where longer time lapses between appearances would occur because the observer is moving very slowly and/or there are larger distances between the viewpoints.

2.2.10 The approach to assessing the significance of cumulative visual effects is guided by the same principles as the approach to the initial project assessment. It has considered the following criteria:

- *“the susceptibility of the visual receptors that have been assessed to changes in views and visual amenity;*
- *the value attached to the views they experience;*
- *the size or scale of the cumulative visual effects identified;*
- *the geographical extent of the cumulative visual effects identified;*
- *the duration of the cumulative visual effects, including the timescales relating to both the project being assessed and the other projects being considered, and the extent to which the cumulative effects may be considered reversible.”*

2.2.11 Higher levels of significance may arise from cumulative visual effects related to:

- *“developments that are in close proximity to the main project and are clearly visible together in views from the selected viewpoints;*
- *developments that are highly inter-visible, with overlapping ZTVs [Zones of Theoretical Visibility] – even though the individual developments may be at some distance from the main project and from individual viewpoints, and when viewed individually not particularly significant, the overall combined*

cumulative effect on a viewer at a particular viewpoint may be more significant.”

2.3 Approach to Assessment

2.3.1 Due to the disassociated nature of the Scheme, the overall assessment of the Scheme is based upon the findings associated with each of the individual Solar PV Sites.

2.3.2 In assessing the Scheme, professional judgment is applied alongside reference to the suite of landscape and visual figures and desktop and site-based assessment.

2.3.3 In reaching the overall assessment of effects associated with the Scheme the cumulative effects of each of the Solar PV Sites and Cable Route are assessed and combined to reach an overall conclusion on where likely significant effects might occur as a result of the Scheme. The approach for the cumulative assessment has two separate divisions under the following headings:

- the assessment of **Cumulative Sites** based on the Solar PV Sites A-E and Cable Route; and
- the assessment of **Cumulative Developments** being the Scheme in combination with other similar developments, these being solar projects in the local area.

2.3.4 **Definition of Cumulative Sites** is based on the Solar PV Sites and is defined as such due to the disassociated nature of the Scheme. In assessing the Scheme, professional judgment is applied alongside reference to the suite of landscape and visual figures and desktop and site-based assessment. The cumulative effects of each of the Solar PV Sites and Cable Route are assessed and the combined set of effects of the Scheme and reached an overall conclusion on where **likely significant effects** might occur as a result of the Scheme.

2.3.5 **Definition of Cumulative Developments** in this assessment considers the additional effects resulting from the Scheme in combination with the effects resulting from other similar developments, these being other solar projects taken together. In this case, the Scheme has assessed the cumulative effects as a combined set of effects as **‘Developments’** reaching an overall conclusion on where likely significant effects might occur based on the following **Cumulative Developments**.

2.4 Assessment of Cumulative Site Effects

2.4.1 The Cumulative Site landscape and visual effects relating to the Cumulative Sites is considered as part of the LVIA cumulative assessment. Cumulative Site

effects relating to the Scheme are considered within the Cumulative Site Assessments for both Landscape and Visual receptors.

2.5 Assessment of Cumulative Development Effects

2.5.1 The Cumulative landscape and visual effects relating to the Cumulative Developments are considered as part of this LVIA cumulative assessment. Cumulative Effects relating to other similar developments (Cumulative Developments) are considered within the Cumulative Developments assessment.

3 Residential Visual Amenity Assessment Methodology

3.1 Introduction

- 3.1.1 Planning law contains a widely understood principle that individuals (i.e., visual receptors at a single residential property) have no 'right to a view' and that the outlook or view from a private property is a private interest and not therefore protected by the UK planning system.
- 3.1.2 However, the UK planning system also recognises situations where the effects on residential visual amenity are considered as a matter of public interest. This matter has been examined at a number of public inquiries where the key determining issue was not the identification of significant effects on views, but whether a development would have an overbearing effect and/or result in unsatisfactory living conditions, leading to a property being regarded, objectively, as an unattractive (as opposed to a less attractive) place in which to live.
- 3.1.3 As a consequence, the visual assessment methodology provides for a much more detailed assessment of the closest residential properties. This allows the assessor, and consequently the determining authority, to make a judgement as to whether the residents at these properties would be likely to sustain unsatisfactory living conditions which it would not be in the public interest to create. Reviews of decisions demonstrate that significant changes to the views available from a residential property, and its curtilage, are not the decisive consideration.
- 3.1.4 By way of further clarification, the methodology for assessing the visual effects on views from residential properties allows for four stages of assessment, which is set out within current guidance on Residential Visual Amenity Assessment (RVAA) contained within the Landscape Institute Technical Guidance Note (TGN) 02/19. Steps 1-3 of RVAA guidance align with the standard LVIA based approach as defined in GLVIA3. The guidance recommends that the effects on residential amenity should be assessed as follows:
- Step 1 – Definition of the Study Area and scope of the assessment
 - Step 2 – Evaluation of Baseline Visual Amenity
 - Step 3 – Assessment of likely change to visual amenity of properties
 - Step 4 – Forming the RVAA judgement
- 3.1.5 Step 4 of the RVAA is defined as being required as follows:
- "In this final step, and only for those properties where the largest magnitude of effect has been identified, a further judgement is required."*

- 3.1.6 The LVIA chapter and appendices are prepared to take account of steps 1-3 as part of the LVIA for the Scheme. Where, following assessment of effects upon residential properties at year 15, there remain significant effects at the highest magnitude of significance (major), then a full RVAA will be undertaken for those properties affected. This is often defined as the Residential Visual Amenity Threshold.
- 3.1.7 The assessment process considers the visual amenity from principal rooms under steps 1-3 above as defined by GLVIA3. At these stages, where likely significant effects are identified for Year 1, the assessment of and conclusion on significance of effect at Year 15 takes into account landscape mitigation measures (both primary and secondary) in views from principal rooms. In forming the judgement for a full RVAA under step 4 above, at Year 15 only, the effects from principal rooms are taken into consideration along with the associated landscape mitigation measures (both embedded and additional).
- 3.1.8 A residential property, for the purpose of environmental impact assessment, should be one that was designed and built/converted for that purpose and currently (at the time of the assessment) remains in a habitable condition, of a safe construction, wind and watertight with appropriate vehicle access, and services (drinking water, sanitation, and power supply). Related buildings such as barns/outbuildings, garage, huts and derelict properties should generally be excluded from the assessment, unless they form part of the curtilage of an existing residence.
- 3.1.9 The susceptibility of individual residential receptors is assessed as high in each case.
- 3.1.10 Whilst most of the properties can be viewed at close range from public roads and footpaths, some of these properties are accessed via private or gated roads and due to these access limitations, they are assessed from the nearest public road or footpath which may be at greater distance from the property. The assessment, in this instance, is regarded as a 'best estimate' of the likely visual effects. In some instances, residential properties are visited and viewed internally when this is requested by the owner.
- 3.1.11 The assessment is further supported by aerial and ground level photography as well as map-based data. The assessment takes account of the likely views from principal rooms and main garden areas but excludes upper floors and other land that may be connected with the property. Relevant information to be considered as part of the assessment for the LVIA process may include, but is not limited to, the following factors:

Scale of the Scheme:

- Number and height of the Scheme elements;
- The horizontal extent or angle of view (AOV) of the Scheme and

- Separation distance (closest and furthest buildings).

Description of the property, as far as can be ascertained:

- Orientation and size of property and whether views from the property towards the Scheme would be direct or oblique;
- Location of principle rooms and main living areas such as living/dining rooms, kitchens and conservatories, as opposed to working areas such as farm buildings and utility areas;
- Location of principle garden areas which may include patios and seating areas as opposed to less well used areas such as paddocks or garages; and
- The effects of any screening by landform, vegetation or nearby built form.

Location and Context:

- The aspect of the property in terms of the overall use and relationship to the garden areas and surrounding landscape;
- The principal direction of main views and visual amenity; and
- The context and nature of any intervening structures e.g., other existing development, farm buildings or forestry.

4 Zone of Theoretical Visibility (ZTV) Methodology

- 4.1.1 For the purpose of the LVIA process in order to assist with viewpoint selection and to appreciate the potential influence of the Scheme in the wider landscape, bare earth ZTV plans (refer to **Volume 2, Figures 8-8, 8-8-1 to 8-8-8**) are used. The bare earth ZTV plans illustrate the area from where it may be theoretically possible to view all, or part, of the Scheme. The ZTV does not however take account of the screening effects of buildings, localised landform, and vegetation, unless specifically mentioned (see represented by individual figures within the LVA process). As a result, there may be roads, tracks and footpaths in the vicinity of the Scheme and in the wider setting which, although shown as falling within the ZTV, are screened or filtered by banks, walls and vegetation which would otherwise preclude viewing opportunities.
- 4.1.2 As a result, the ZTVs provide a starting point in the assessment process and accordingly tend towards giving a 'worst case' or greatest calculation of the theoretical visibility.
- 4.1.3 The Environment Agency's LiDAR Terrain dataset was used as the Digital Terrain Model (DTM) for the Bare Earth ZTV. The DTM is a 2 m by 2 m raster dataset that is representative of the landform across England. The effect of earth curvature and light refraction are included in the Bare Earth ZTV analysis and a viewer height of 1.7m above ground level is used.
- 4.1.4 The ZTV was produced using ESRI ArcGIS Pro 3.5.1 software, utilising the viewshed geoprocessing tool which creates a raster image indicating visibility (or not) of the Scheme.
- 4.1.5 Further augmented ZTV's (refer to **Volume 2, Figures 8-9, 8-9-1 to 8-9-8**) are also produced utilising the Environment Agency's Digital Surface Model (DSM). Woodland blocks from the Forestry Commissions National Forest Inventory dataset and hedgerows provided from a topographical survey are indicatively added to the DSM to give an impression of likely screening of views. Specific viewpoints (for example, a key view from a specific visitor attraction) are then identified taking into account the following criteria:
- Illustrative viewpoints (chosen to demonstrate a particular effect/specific issue);
 - Any important sequential views, for example, along key transport routes; and
 - Any additional viewpoints that are requested by consultees at Scoping.
- 4.1.6 For the purpose of the LVIA process, all of the viewpoints are taken from publicly accessible land.

LVIA Glossary

Term	Definition
Access land	Land where the public have access either by legal right or by informal agreement.
Baseline studies	Work done to determine and describe the environmental conditions against which any future changes can be measured or predicted and assessed.
Characterisation	The process of identifying areas of similar landscape character, classifying and mapping them, and describing their character.
Characteristics	Elements, or combinations of elements, which make a contribution to distinctive landscape character.
Compensation	Measures devised to offset or compensate for residual adverse effects which cannot be prevented/avoided or further reduced.
Competent authority	The authority which determines the application for consent, permission, licence or other authorisation to proceed with a proposal. It is the authority that must consider the environmental information before granting any kind of authorisation.
Consultation bodies	Anybody specified in the *Infrastructure Planning (Environmental Impact Assessment) Regulations 2017 (the EIA Regulations) which the competent authority must consult in respect of an EIA, and which also has a duty to provide a scoping opinion and information.
Designated landscape	Areas of landscape identified as being of importance at international, national, or local levels, either defined by statute or identified in development plans or other documents.
Development	Any proposal that results in a change to the landscape and/or visual environment.
Direct effect	An effect that is directly attributable to the Scheme.
'Do Nothing' situation	Continued change or evolution in the landscape in the absence of the proposed development.
Ecosystem services	The benefits provided by ecosystems that contribute to making human life both possible and worth living. The Millennium Ecosystem Assessment grouped ecosystem services into four broad categories: Supporting services, such as nutrient cycling, oxygen production and soil formation. These underpin the provision of the other 'service' categories. Provisioning services, such as food, fibre, fuel and water. Regulating services, such as climate regulation, water purification and flood protection. Cultural services, such as education, recreation, and aesthetic value.
Environmental Impact Assessment (EIA) Regulations	The EIA Regulations form part of the development management system in England. The EIA Regulations cover certain types of development which have the potential to give rise to significant effects on the environment. The EIA Regulations enable planning authorities to understand and take account of the environmental implications of development in their decisions on planning applications. The EIA Regulations applicable to this DCO application are the Infrastructure Planning (Environmental Impact Assessment) Regulations 2017.

Term	Definition
Elements	Individual parts which make up the landscape, such as, for example, trees, hedges, and buildings.
Enhancement	Proposals that seek to improve the landscape resource and the visual amenity of the Scheme and its wider setting, over and above its baseline condition.
Environmental Impact Assessment (EIA)	The process of gathering environmental information; describing a development; identifying and describing the likely significant environmental effects of the project; defining ways of preventing/avoiding, reducing, or offsetting or compensating for any adverse effects; consulting the general public and specific bodies with responsibilities for the environment; and presenting the results to the competent authority to inform the decision on whether the project should proceed.
Environmental statement	A statement that includes the information that is reasonably required to assess the environmental effects of the development and which the applicant can, having regard in particular to current knowledge and methods of assessment, reasonably be required to compile, but that includes at least the information referred to in the EIA Regulations.
Feature	Particularly prominent or eye-catching elements in the landscape, like tree clumps, church towers, or wooded skylines or a particular aspect of the project proposal.
Geographical Information System (GIS)	A system that captures, stores, analyses, manages, and presents data linked to location. It links spatial information to a digital database.
Green Infrastructure (GI)	Networks of green spaces and watercourses and water bodies that connect rural areas, villages, towns, and cities.
Heritage	The historic environment and especially valued assets and qualities such as historic buildings and cultural traditions.
Historic Landscape Characterisation (HLC) and Historic Land-use Assessment (HLA)	Historic characterisation is the identification and interpretation of the historic dimension of the present-day landscape or townscape within a given area. HLC is the term used in England and Wales, HLA is the term used in Scotland.
Indirect effects	Effects that result indirectly from the proposed project, as a consequence of the direct effects, often occurring away from the Scheme, or as a result of a sequence of interrelationships or as a result of a complex pathway. They may be separated in distance or in time from the source of the effects.
Iterative design process	The process by which project design is amended and improved by successive stages of refinement which respond to growing understanding of environmental issues.
Key characteristics	Those combinations of elements which are particularly important to the current character of the landscape and help to give an area its particularly distinctive sense of place.
Land use	What land is used for, based on broad categories of functional land cover such as urban and industrial use and the different types of agriculture and forestry.
Land cover	The surface cover of the land, usually expressed in terms of vegetation cover or lack of it. Related to but not the same as land use.

Term	Definition
Landform	The shape and form of the land surface which has resulted from combinations of geology, geomorphology, slope, elevation and physical processes.
Landscape	An area, as perceived by people, whose character is the result of the action and interaction of natural and/or human factors.
Landscape Fabric	Landscape fabric is the individual tangible elements or features such as landform, woodland, hedges, tree cover, vegetation that make up a landscape or site. These can usually be described and quantified.
Landscape and Visual Impact Assessment (LVIA)	Landscape and Visual Impact Assessment (LVIA) is a tool used to identify and assess the likely significance of the effects of change resulting from development on both the landscape as an environmental resource in its own right and on people's views and visual amenity.
Landscape character	A distinct, recognisable, and consistent pattern of elements in the landscape that makes one landscape different from another, rather than better or worse.
Landscape Character Assessment (LCA)	Landscape character assessment is the process of identifying and describing variation in the character of the landscape and using this information to assist in managing change in the landscape. It seeks to identify and explain the unique combination of elements and features that make landscapes distinctive. The process results in the production of a Landscape Character Assessment.
Landscape Character Types (LCTs)	These are single unique areas which are the discrete geographical areas of a particular landscape type.
Landscape classification	A process of sorting the landscape into different types using selected criteria but without attaching relative values to different sorts of landscape.
Landscape effects	Effects on the landscape as a resource in its own right.
Landscape quality (Condition)	A measure of the physical state of the landscape. It may include the extent to which typical character is represented in individual areas, the intactness of the landscape and the condition of individual elements.
Landscape receptor	A defined aspect of the landscape resource that has the potential to be affected by a proposal.
Landscape strategy	The overall vision and objectives for what the landscape should be like in the future, and what is thought to be desirable for a particular landscape type or area as a whole, usually expressed in formally adopted plans and programmes or related documents.
Landscape value	The relative value that is attached to different landscapes by society. A landscape may be valued by different stakeholders for a whole variety of reasons.
Magnitude (of effect)	A term that combines judgments about the size and scale of the effect, the extent of the area over which it occurs, whether it is reversible or irreversible and whether it is short or long term in duration.
Parameters	A limit or boundary which defines the scope of a particular process or activity.
Perception	Combines the sensory (received through senses) with the cognitive (knowledge and understanding gained from many sources and experiences).

Term	Definition
Photomontage	A visualisation which superimposes an image of a proposed development upon a photograph or series of photographs.
Scoping	The process of identifying the issues to be addressed by an EIA. It is a method of ensuring that an EIA focuses on the important issues and avoids those that are considered to be less significant.
Sensitivity	A term applied to specific receptors, combining judgments of the susceptibility of the receptor to the specific type of change or development proposed and the value related to that receptor.
Significance	A measure of the importance or gravity of the environmental effect, defined by significance criteria specific to the environmental topic.
Stakeholders	The whole constituency of individuals and groups who have an interest in a subject or place.
Strategic Environmental Assessment	The process of considering the environmental effects of certain public plans, programmes, or strategies at a strategic level.
Susceptibility	The ability of a defined landscape or visual receptor to accommodate the specific proposed development without undue negative consequences.
Time depth	Historical layering - the idea of landscape as a 'palimpsest', a much written over manuscript.
Townscape	The character and composition of the built environment including the buildings, the relationships between them, the different types of urban open spaces, including greenspaces, and the relationship between buildings and open spaces.
Tranquillity	A state of calm and quietude associated with peace, considered to be a significant asset of landscape.
Visual amenity	The overall pleasantness of the views people enjoy of their surroundings, which provides an attractive visual setting or backdrop for the enjoyment of activities of the people living, working, recreating, visiting or travelling through an area.
Visual effect	Effects on specific views and on the general visual amenity experienced by people.
Visual receptors	Individuals and/or defined groups of people who have the potential to be affected by a proposal.
Visualisation	Computer simulation, photomontage, or other technique to illustrate the predicted appearance of a development.
Zone of Theoretical Visibility (sometimes Zone of Visual Influence)	A map, usually digitally produced, showing areas of land within which a development is theoretically visible.
* Change/s to Glossary when compared with standard GLVIA3 Glossary.	

References

- Ref.1 Landscape Institute and Institute of Environmental Management and Assessment, 2013, Guidelines for Landscape and Visual Impact Assessment, 3rd Edition, Routledge, London.
- Ref.2 An Approach to Landscape Character Assessment (October 2014) (Christine Tudor, Natural England) Countryside Agency and Scottish Natural Heritage (SNH), (2002) Landscape Character Assessment: Guidance for England and Scotland. [Online] Available at [landscape-character-assessment.pdf](https://publishing.service.gov.uk) (publishing.service.gov.uk) (Last accessed 13/12/2021).
- Ref.3 Landscape Institute (1 September 2019) Technical Guidance Note 06/19 Visual Representation of Development Proposals.
- Ref.4 Landscape Institute (26 May 2021) Technical Guidance Note 02/21 Assessing landscape value outside national designations.
- Ref.5 Landscape Institute Draft Technical Guidance Note LITGN-2024-01 (August 2024) Notes and Clarifications on aspects of the 3rd Edition Guidelines on Landscape and Visual Impact Assessment (GLVIA3).
- Ref.6 Landscape Institute (26 May 2021) Technical Guidance Note 02/21 Assessing landscape value outside national designations.
- Ref.7 Guidelines for Landscape and Visual Impact Assessment, 3rd Edition, Routledge, London Paragraph 3.40.
- Ref.8 2013, Guidelines for Landscape and Visual Impact Assessment, 3rd Edition, Routledge, London Paragraph 3.42.
- Ref.9 The European Landscape Convention for the UK. Available online at <https://www.gov.uk/government/publications/european-landscape-convention-guidelines-for-managing-landscapes>.
- Ref.10 Landscape Institute, 'Technical Guidance Note (TGN) 02/21 Assessing landscape value outside national designations', May 2021.
- Ref.11 Landscape Institute Guidelines for Landscape and Visual Impact Assessment, 3rd Edition, Paragraph 5.40, Page 88.
- Ref.12 Guidelines for Landscape and Visual Impact Assessment (page 90)
- Ref.13 Ibid. 1. Paragraph 6.32.
- Ref.14 Landscape Institute and Institute of Environmental Management and Assessment, 2013, Guidelines for Landscape and Visual Impact Assessment, 3rd Edition, Routledge, London. Glossary Page 155 to 159.{Reference details}

5 Photography and Photomontage Methodology

Contents

	Page
Introduction	1
Verified Photography and 3D Modelling	1
Surveying	2
3D Modelling	3
Area A	4
Area B	5
Area C	6
Area D	7
Area E	8
Planar or Cylindrical Projection	10
3D Modelling Software	10
Viewing Printed Images	10
Summary	10
Appendix 1.1 Technical Viewpoint Sequences	
Appendix 1.2 Layout Information used for 3D Model Construction	
Appendix 1.3 Survey Equipment	
Appendix 1.4 Camera Equipment	

Introduction

A photography and visualisation team was pulled together of leading photography and visualisation specialists from across the UK. Co-ordinated by Lanpro and led by Mike Spence of MSEnvision. Mike brings over 30 years photography and visualisation experience, working on a wide range of complex infrastructure projects, from major Highways schemes, to Carbon Capture, power station development, tall buildings and solar projects across the UK.

Mike was a key technical author of the Landscape Institute's TGN 06/19 on visualisation of development proposals. He has worked alongside The National Trust, Historic England, English Heritage, RBG Kew, Historic Royal Palaces, Friends of the Earth, as well as NatureScot (formerly Scottish Natural Heritage) for whom he is currently working on updates to their windfarm visualisation guidance.

In 2024 Lanpro discussed the scope of the work with Mike Spence to develop a consistent strategy for technical photography and generation of highly accurate visualisations for major solar panel infrastructure. 102 viewpoints were identified. Winter time photographs were taken in January 2025 and summer photographs taken in June 2025.

Verified Photography and 3D Modelling

The photographs were taken with a full frame camera (Canon EOS 5D Mark IV) and 50mm lens combination consistent with Landscape Institute's TGN 06/19, GLVIA3 and the emerging understanding of the requirement for technical photography for visualisation work. As part of the work a total of 102 viewpoints were identified providing views of the development and visited for summer and winter photography in 2025.

Technical Photography

The camera was mounted on a Manfrotto 303 SPH panoramic tripod head, levelled using a Manfrotto Leveller, supported on a Manfrotto Tripod. The tripod head was levelled using a spirit level, to avoid pitch and roll. The camera was set with the centre of the lens 1.60m above ground level. Photographs were taken in Manual mode with an aperture of f/8 or f/11 and a fixed focal length throughout. Photographs were taken in landscape orientation. A Sigma 50mm f/1.4 lens was used for all viewpoint photographs. Three sets of equipment were used. The equipment was identical.



A Single Frame 50mm photograph is insufficient to capture the extents of a wide, linear development. Each view was taken with a series of overlapping 50mm images, as shown above.



To ensure consistent geometry each image was cylindrically re-projected, as above. This ensures that a full 360 degree panorama can be created to match the 3D model view, as shown below:



From the 360 degree panorama a 90 (or 180 degree) degree portion can be extracted to present the visualisations as shown below:



Surveying

The position of each camera location was surveyed using Spectra Precision GNSS equipment with Real Time Kinematic Correction (RTK) which achieves an accuracy down to 1cm in eastings, northings and height (metres Above Ordnance Datum). The equipment included Spectra Precision SP80 & SP85 GNSS smart antennae with Panasonic Toughpad data recorder. Points were saved using DigiTerra software. Photographs of the camera/tripod location were taken.



3D Modelling

MSEnvision (MSE) constructed a 3D model using the layout data supplied by Lanpro, OS Master-Map for geo-referencing and Environment Agency LIDAR DTM (2m). 3D point data was used for checking horizontal and vertical alignment.

For all viewpoints a 360 degree view was generated to capture the full extents of the development. This ensured that the full development would be present in the visualisations.

Camera locations surveyed on site were added to the geo-referenced 3D model.

Target points were taken from the existing features in the view and built into the 3D model. This allowed the horizontal and vertical alignment of the photograph and 3D model to be checked, cross-referenced and verified.

Cylindrical renders generated using V-Ray for Rhino were exported from the 3D modelling software and used to overlay the cylindrical images. Target points from both the photograph and the model view were aligned to ensure a precise fit between the two images.

Visualisations are presented as either AVR 0, 1, 2 or 3. The differences are explained in the Landscape Institute's Technical Guidance Note 06/19: Visualisation of Development Proposals.

The results are presented as a sequence of visualisations as follows:

Existing Summer View



Existing Winter View



3D Model View (AVR2/3)



3D Model Composite View (AVR2/3)



Landscaping Year 1 (AVR2/3)



Landscaping Year 15 (AVR2/3)

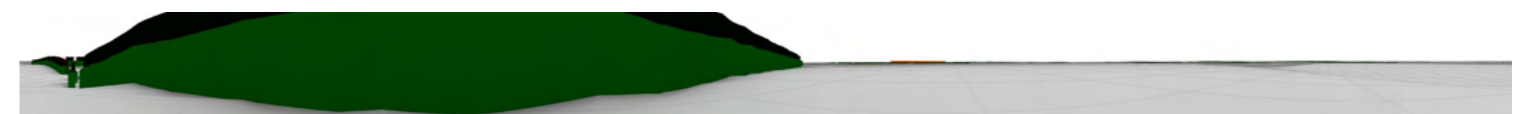

The topography of the site has been generated from DEFRA LIDAR 2m DTM data, with triangulated surfaces generated using Rhinoterrain.

The model is fully geo-referenced and has been constructed with panels aligning with panel locations shown in the engineering layouts. The panels have been aligned to follow the rolling landform using Pythonscript.

The following assumptions have been applied in relation to the representation of the BESS, 132 kV and 400 kV substation infrastructure.

The maximum BESS and substation parameters have been modelled using the highest existing ground level within areas identified for these Scheme components within the Works Plan [APP-007] as Works Nos. 2, 3A, or 3B (Works Area), based on the detailed layout information provided by the engineering team. For each numbered Works Area, a consistent horizontal datum has been applied across the entirety of the Works Area, to create a box derived from the highest existing ground level (mAOD) within that numbered Works Area.

Accordingly, the maximum design parameters (for example the 13 m height parameter associated with the 400 kV substation) are measured from this highest point and then projected consistently across the full extent of the relevant numbered Works Area. As a result, where existing ground levels fall away across the site, the apparent height of the parameter box may exceed the stated maximum parameter height when viewed relative to local ground levels.

This approach represents a robust and precautionary worst-case assumption, as it avoids under-representing the potential visibility and scale of the proposed infrastructure within areas of falling topography.

Lanpro have supplied a landscaping scheme which included Proposed Hedgerows and Trees, Proposed Linear Tree Planting, Proposed Native Woodland Belt, Proposed Native Woodland Block, Proposed Riparian Corridor and Proposed Native Tree and Shrubs.







Three 3D models were constructed to illustrate the effectiveness of the planting effectiveness of the planting proposals for years 1 and 15. We also include a 3D model infrastructure render with no planting.

The 3D models have been split to illustrate:

- Area A**
- Area B**
- Area C**
- Area D**
- Area E**

Sub-stations have been included in the 'Area models'.

Landscaping Specification supplied by Lanpro:

A	B	C	D
Typology name	Line type on CAD/DWG	Line Heights at Year 1	Line Heights at Year 15
Hedge to be reinforced		One line extrusion: 2.2m	Two line extrusions: 4.5m 7.5m
Proposed Native Hedgerow And Trees		Two line extrusions: 0.7m 2.2m	Two line extrusions: 4.5m 7.5m
Proposed Linear Tree Planting		One line extrusion: 2.2m	One line extrusion: 7.5m
Proposed Native Woodland Belt		Two line extrusions: 0.7m 2.2m	One line extrusion: 7.5m
Proposed Native Woodland Block		Two line extrusions: 0.7m 2.2m	One line extrusion: 7.5m
Proposed Riparian Corridor		One line extrusion: 0.7m	One line extrusion: 4.5m
Proposed Native Tree and Shrub		Two line extrusions: 0.7m 2.2m	Two line extrusions: 4.5m 7.5m

Full 3D Model on 2m LIDAR DTM data (OSGB36)

INFRASTRUCTURE

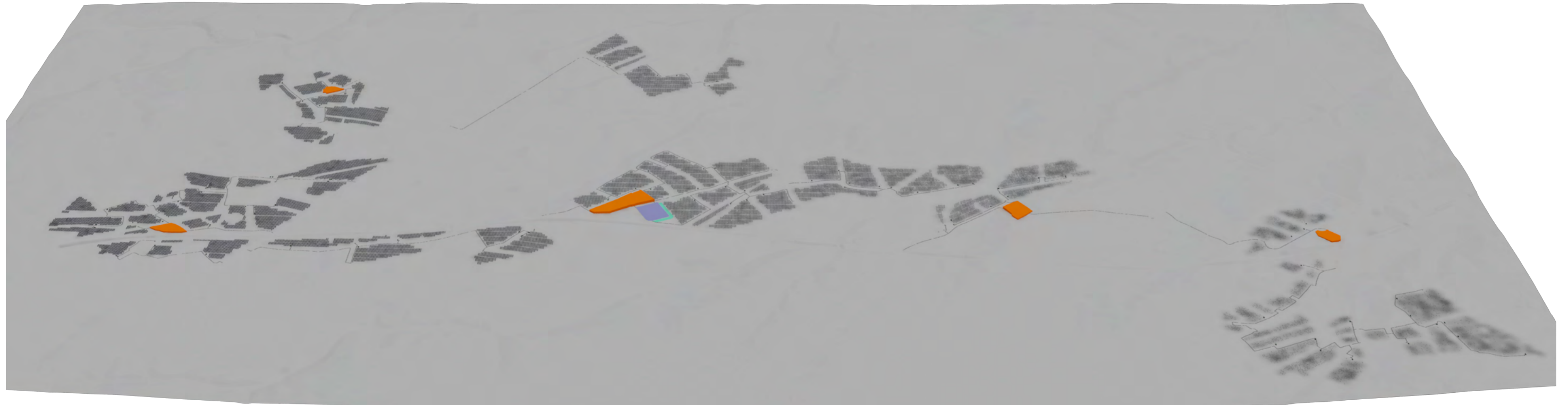

YEAR 15 LANDSCAPING

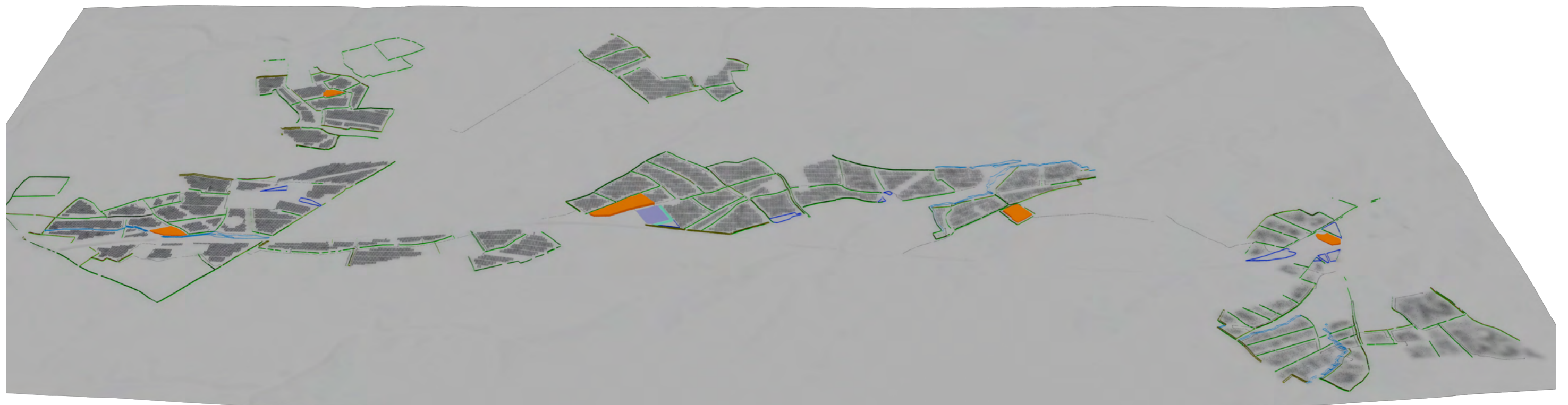

AREA A
3D Model on 2m LIDAR DTM data (OSGB36)

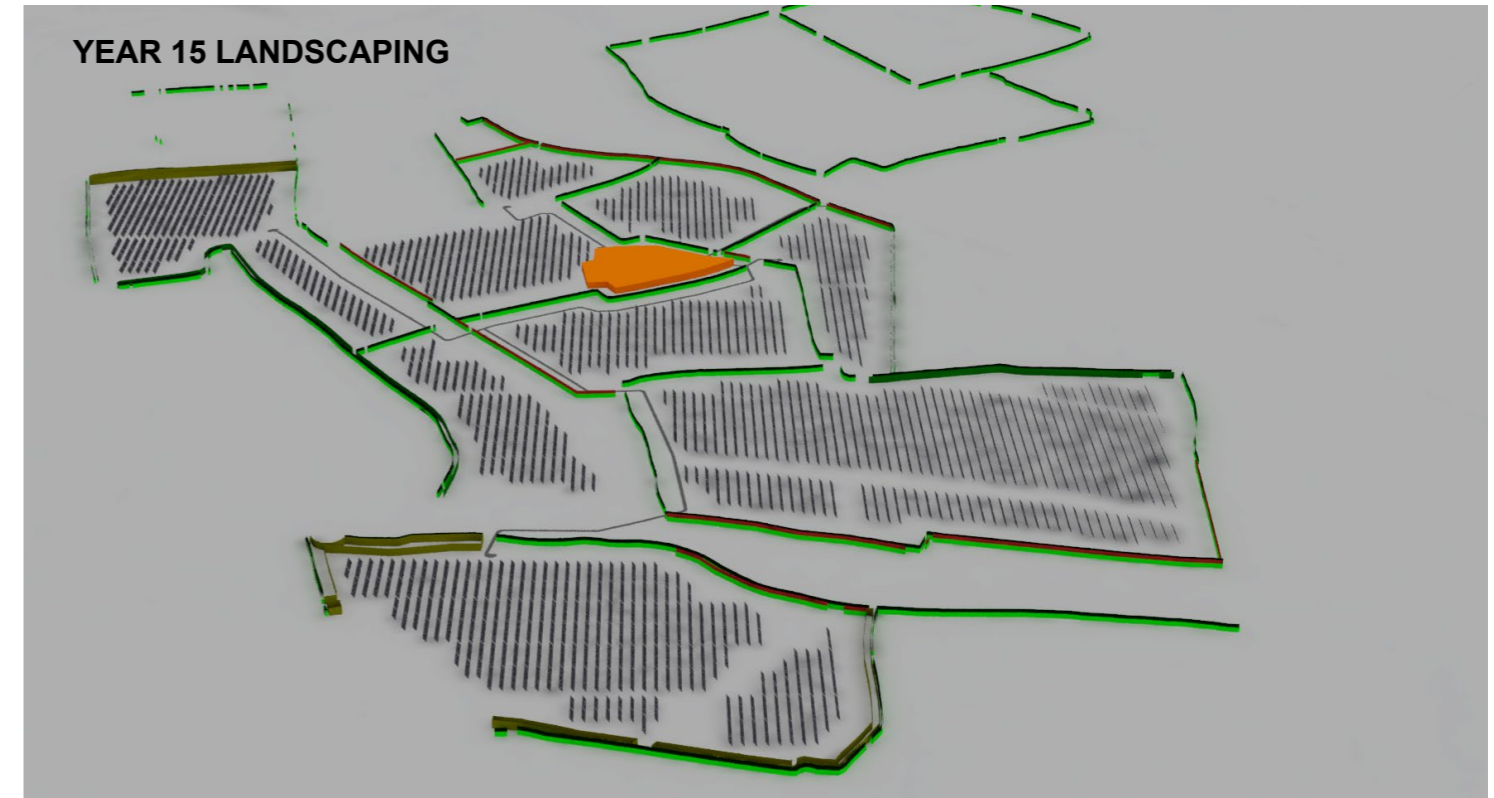
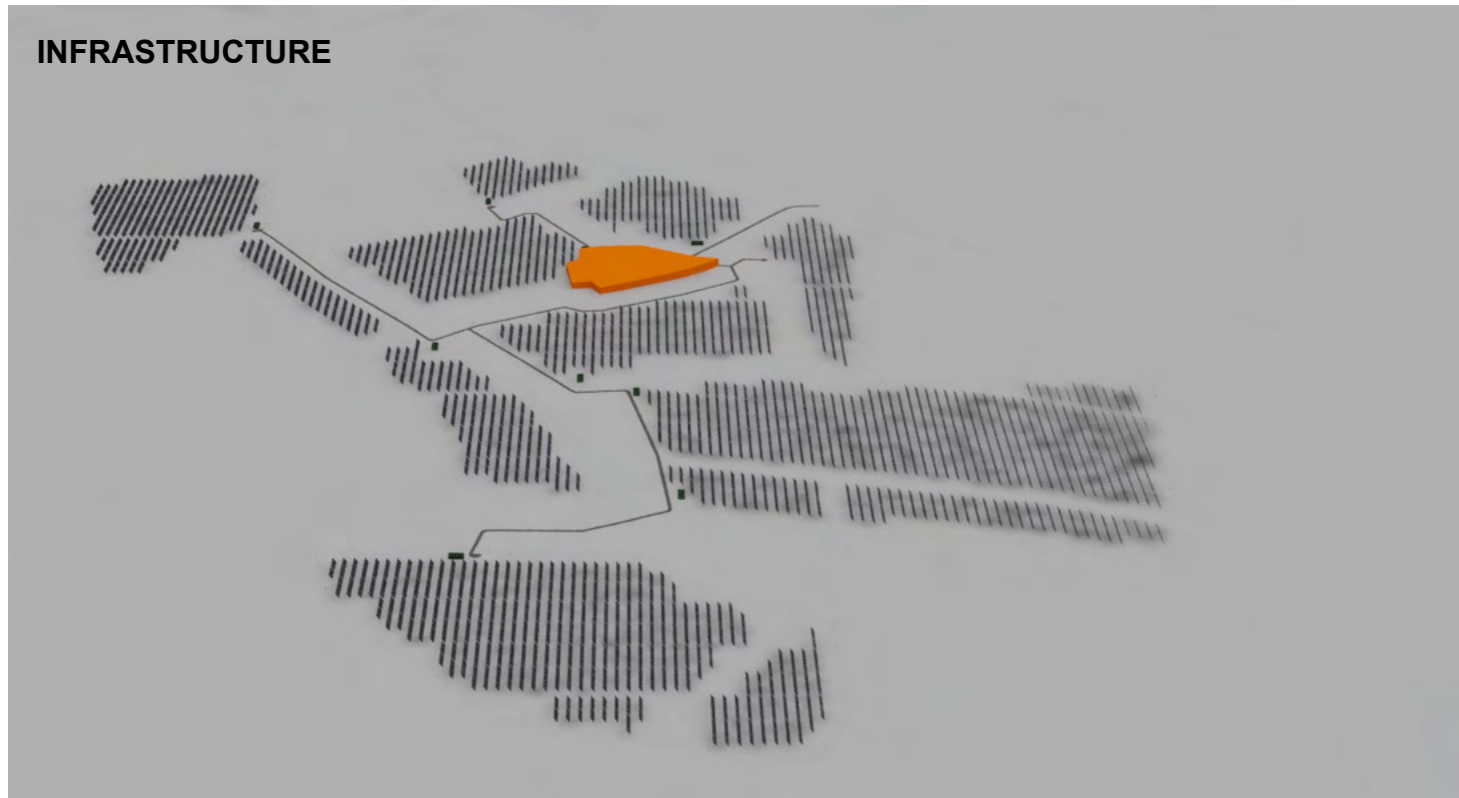

AREA B
3D Model on 2m LIDAR DTM data (OSGB36)

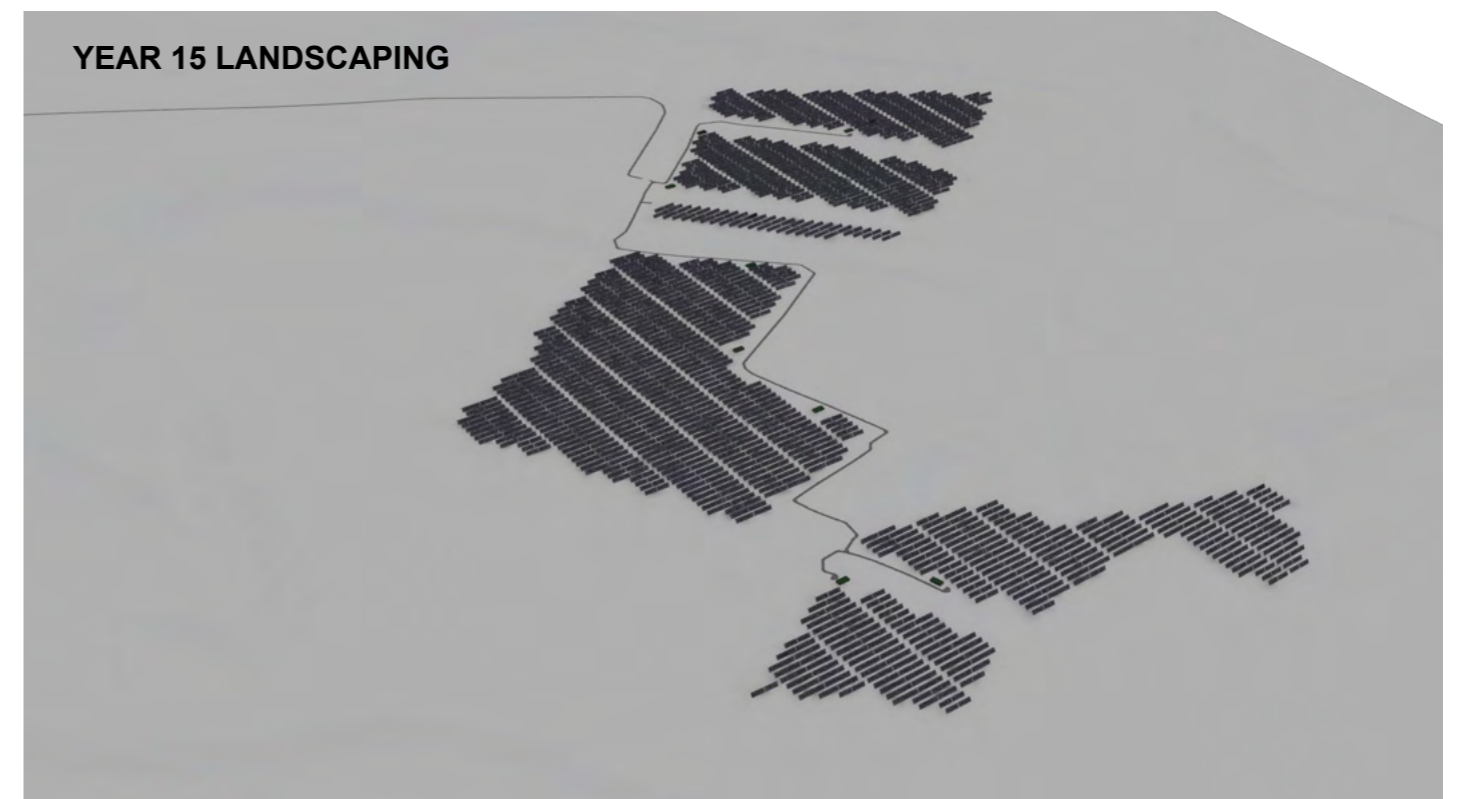
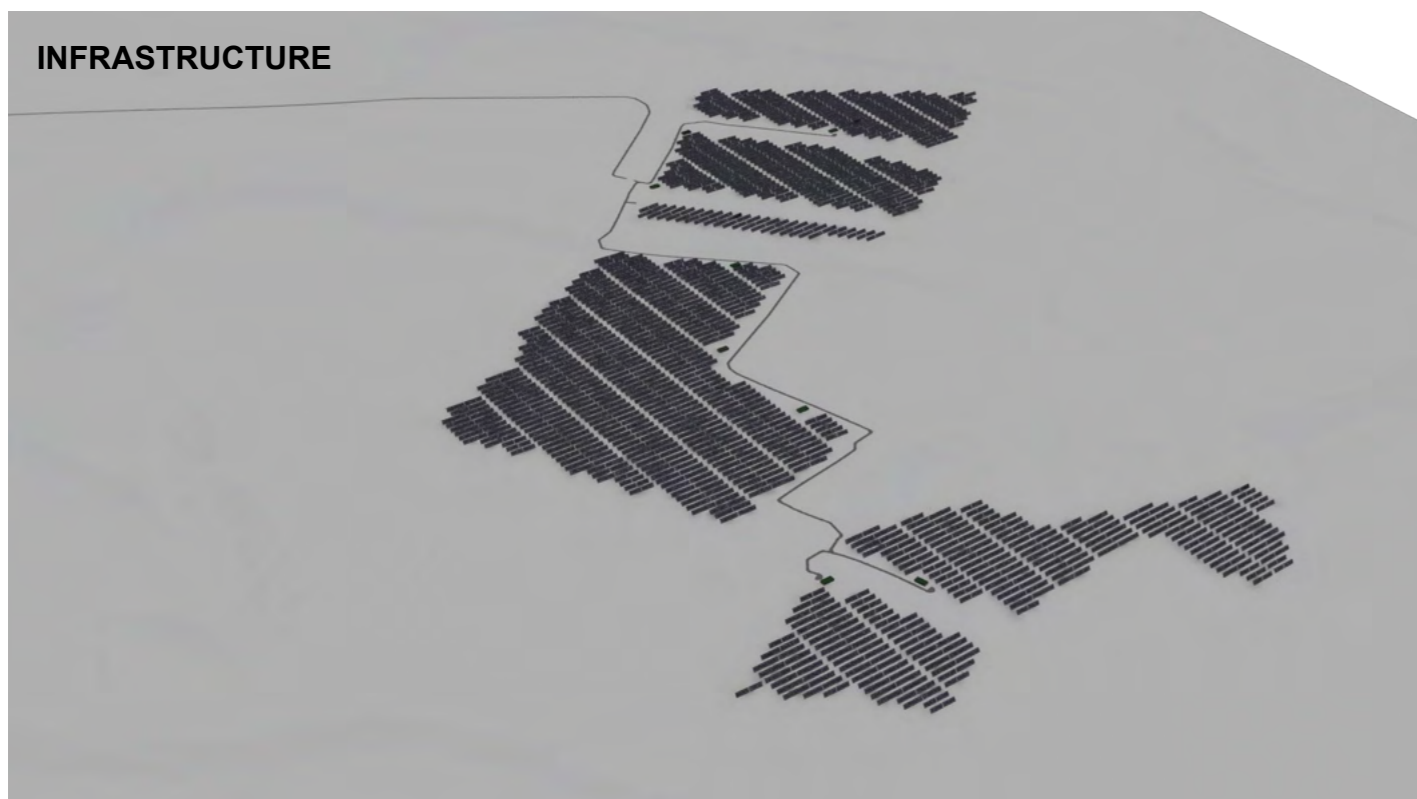

AREA C
3D Model on 2m LIDAR DTM data (OSGB36)

INFRASTRUCTURE



YEAR 15 LANDSCAPING



AREA D
3D Model on 2m LIDAR DTM data (OSGB36)

INFRASTRUCTURE

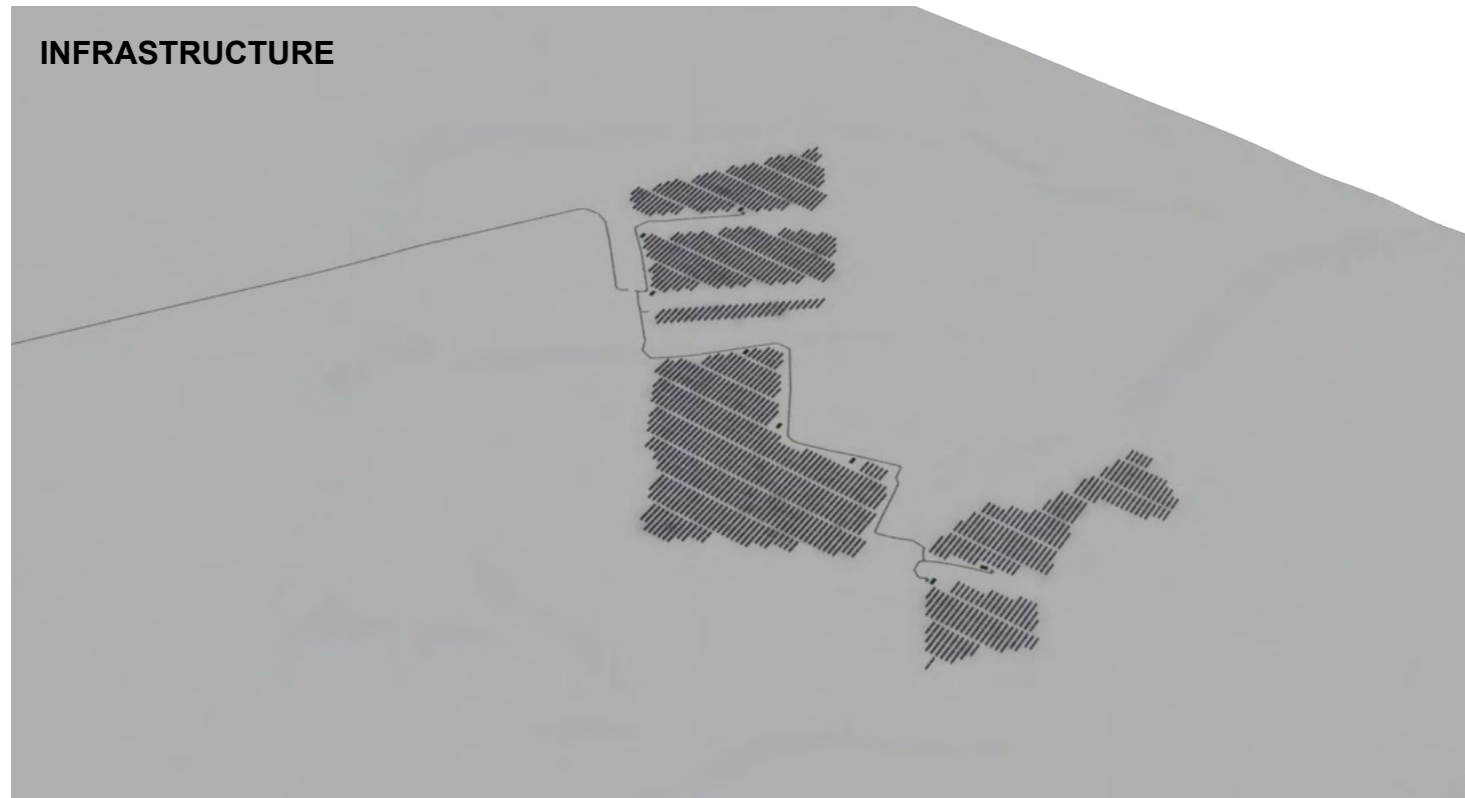

YEAR 15 LANDSCAPING

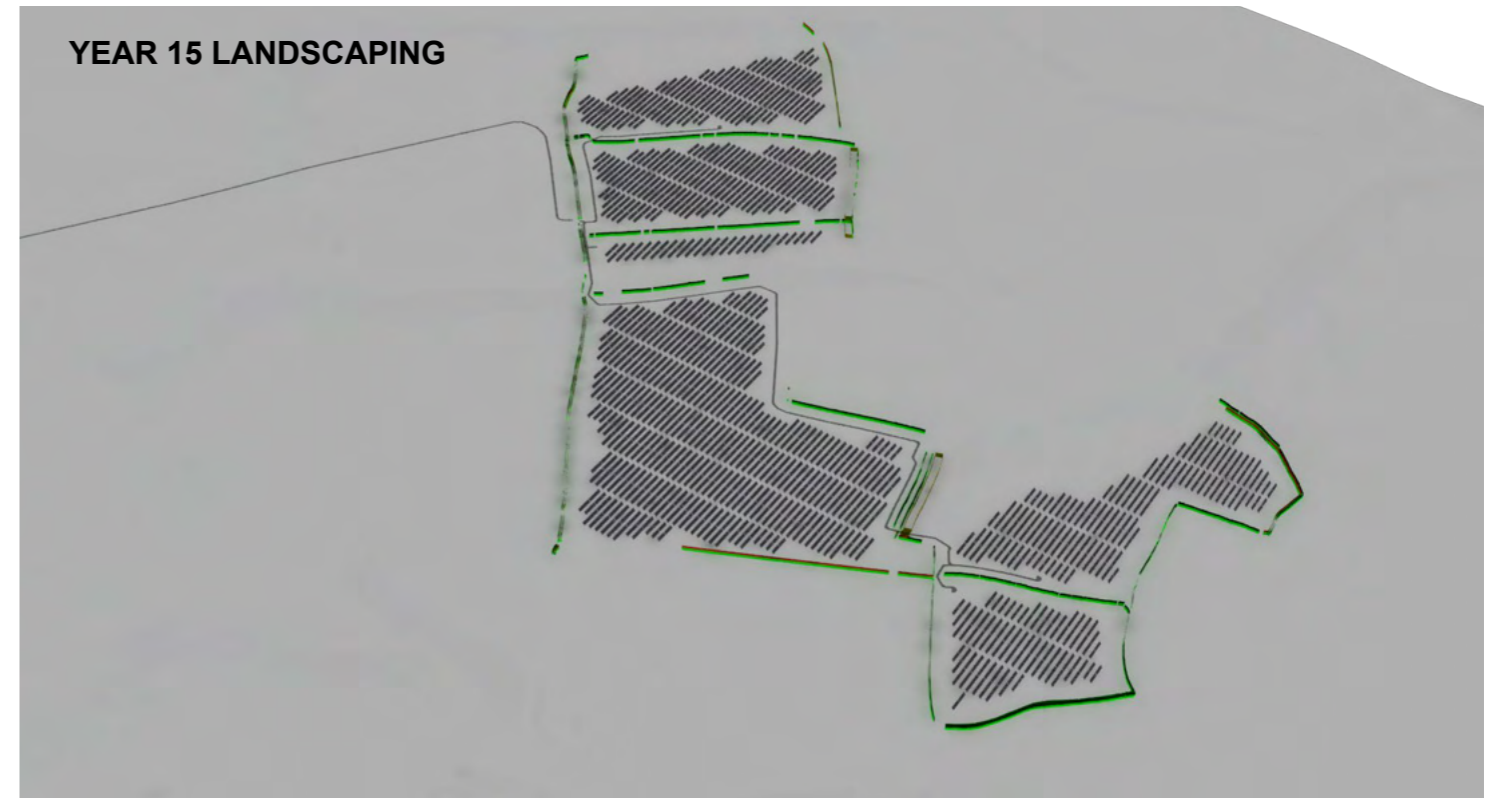

AREA E
3D Model on 2m LIDAR DTM data (OSGB36)

INFRASTRUCTURE

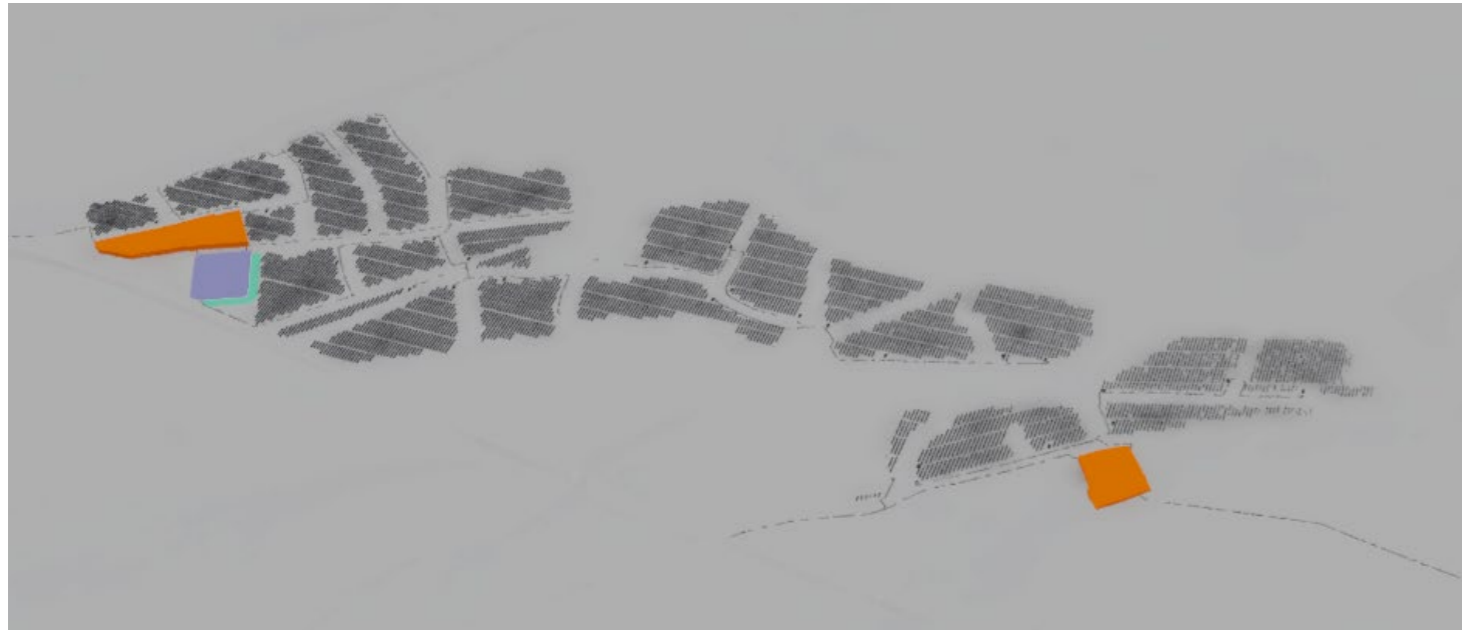

YEAR 15 LANDSCAPING

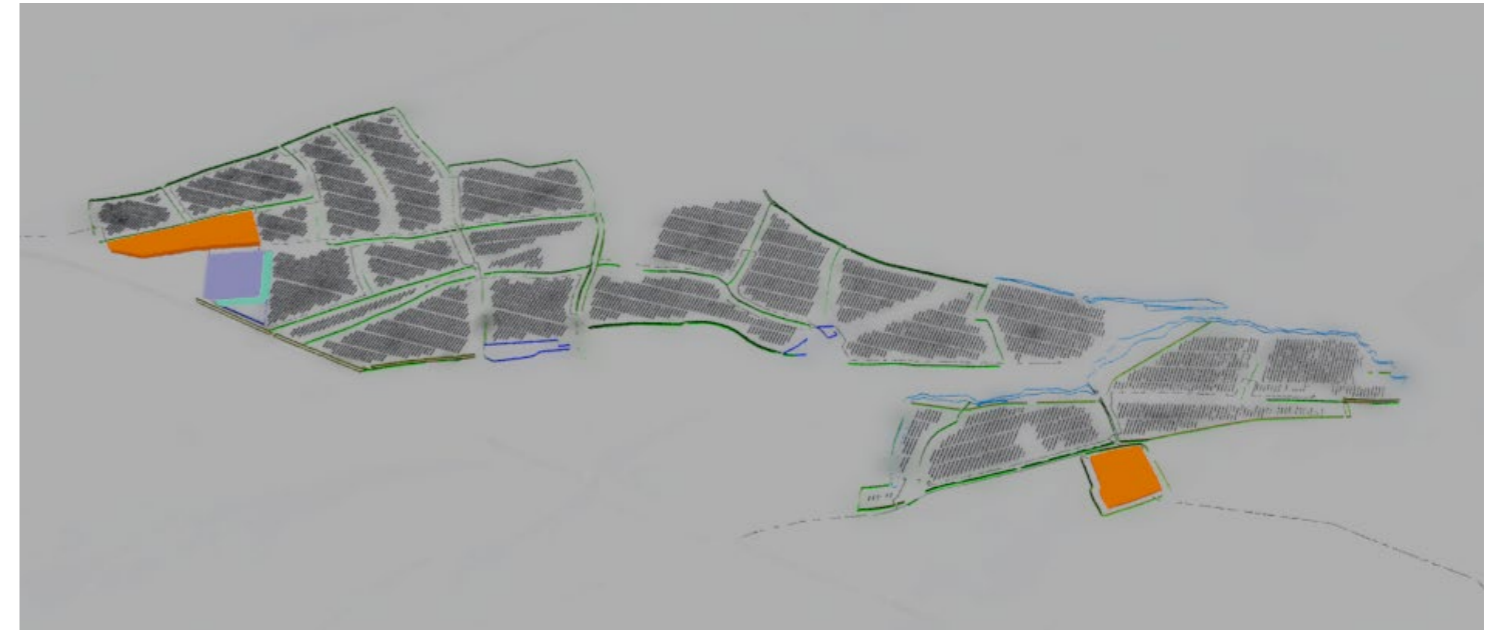

50mm lens on Full Frame Sensor Camera

For decades it has been accepted that a 50mm lens on a full frame sensor camera provides the optimum image to replicate what is seen by the human eye. There are important differences between the human eye (binocular) and the camera lens (monocular). These have been explored in research by The Highland Council & the University of Stirling, as well as by myself through the Landscape Institute. We know that a single frame 50mm image on an A3 sheet of paper provides the same view as that gained in the field by someone with one eye closed. As we are binocular, and normally use both eyes, a different size of image is required, and the reason why we have presented the images as effectively a 75mm image on A2 paper. This gives what The Highland Council, University of Stirling, Scottish Natural Heritage (NatureScot) and the Landscape Institute agree is the most representative size of image to understand the nature and scale of a development on a photograph.

Planar or Cylindrical Projection

All photographs are taken as single frame planar images. Each single frame image has a single point of perspective lying at the centre of the image. To correctly match and align with the 3D modelling software the camera must be mounted on a levelled tripod, and directed towards the proposed development.

When a viewpoint is close to the development, or a development is wide such as this solar farm, it is rarely possible to fit the development on a single frame image. The alternative is to use a series of overlapping 50mm images and generate a 'cylindrical' perspective view. This can be a full 360 degree wide panorama.

The 3D model renders have been rendered out in cylindrical (multiple frame images) projection to allow the precise image re-mapping to match the photography.

3D Modelling software

The work has largely been undertaken using Rhino 3D. All 3D modelling has been undertaken in metres and geo-referenced to align with OSGB36. RESOFT Windfarm was also used which is a 3D modelling package which we use to check on vertical and horizontal alignment of the 3D model against the precise image geometry. This is also set up to OSGB36. RESOFT Windfarm has been used to generate the geometric grid from LIDAR DTM data present in all 3D model visualisations.

Viewing Printed Images

The visualisations have been prepared to be printed at A1 wide x A4 high (841 x 297mm) and in this technical methodology document at A3 (420mm x 297mm), to fully show the original photographic imagery and scale of the proposed development.

The image size is considered to give a fair representation of the view for everyone, and the scale of the development in that view.

Summary

This work has been undertaken in accordance with the the Landscape Institute TGN 06/19 and the developing understanding of visualisation work. The accuracy of camera locations and 3D modelling conforms with the Landscape Institute's Type 4 (the highest level of accuracy). The 3D modelling has been produced to AVR 3 (photorealistic).

The photography has been undertaken in an extremely robust manner, using professional full frame sensor DSLR and 50mm lens with levelled tripod. The camera position has been surveyed using highly accurate GNSS Smart Antennae equipment, giving high levels of accuracy of camera location. The 3D model has been built in Rhino 3D using detailed information supplied by the engineers and a comprehensive landscaping scheme supplied by Lanpro. An additional check on the vertical scaling has been undertaken using RESOFT Windfarm.

The resultant visualisations are highly accurate.

The photography, surveying and 3D modelling have followed a transparent methodology, and the resultant visualisations and the size at which they are presented are considered robust and fit for purpose to illustrate the positioning, and scale and massing of the proposed scheme in its local and wider context.

APPENDIX 1.1: VIEWPOINT LOCATIONS

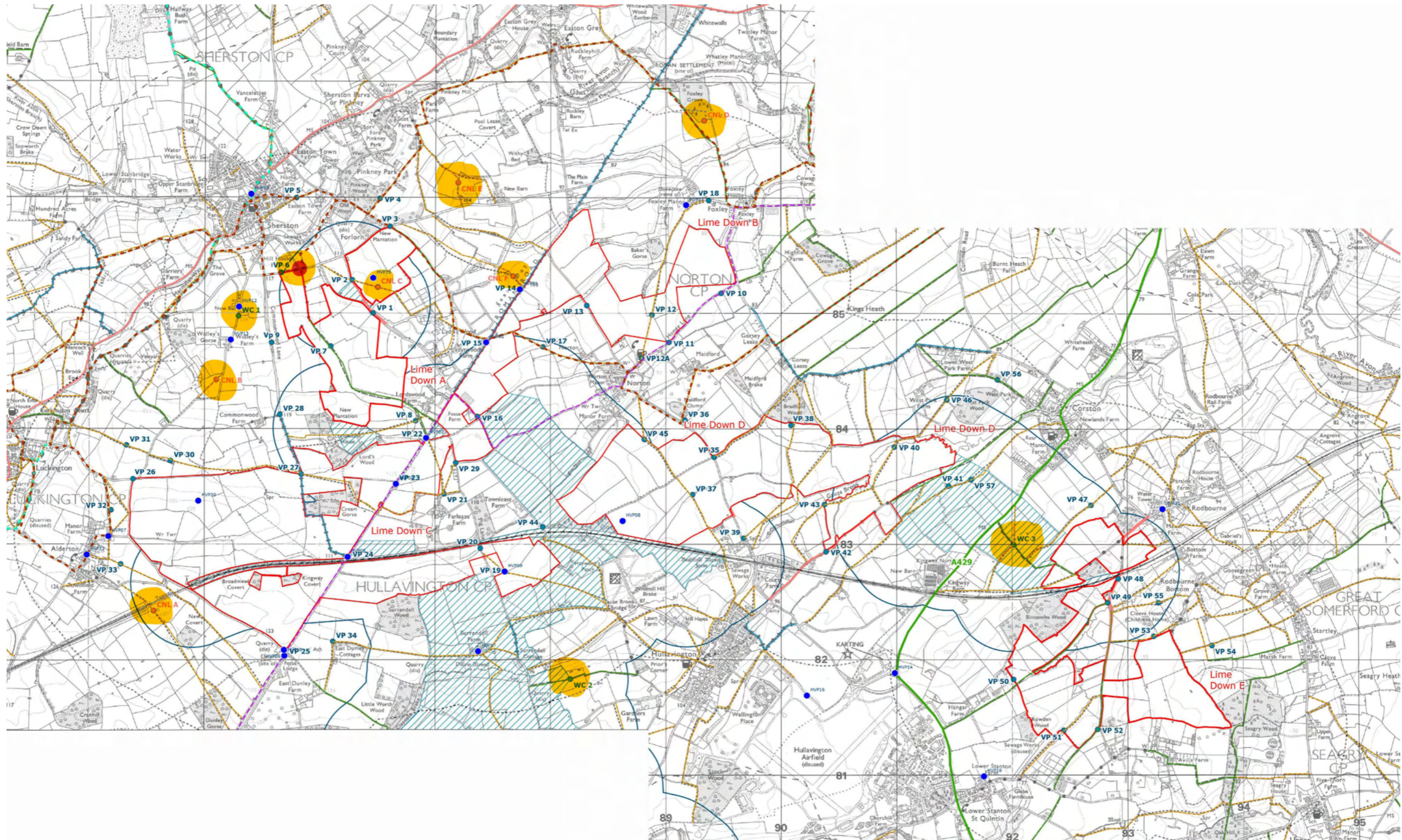

APPENDIX 1.2: LAYOUT INFORMATION USED FOR 3D MODEL CONSTRUCTION

APPENDIX 1.3: SURVEY EQUIPMENT

TOUGHPAD FZ-G1

Panasonic recommends Windows.

SOFTWARE	<ul style="list-style-type: none"> Windows 10 Pro 64 bit Panasonic Utilities (including Dashboard, Recovery Partition) 														
DURABILITY	<ul style="list-style-type: none"> MIL-STD-810G certified (4' drop, shock, vibration, rain, dust, sand, altitude, freeze/thaw, high/low temperature, temperature shock, humidity, explosive atmosphere) IP65 certified sealed all-weather design Optional class I division 2, groups ABCD certified model Solid state drive heater Magnesium alloy chassis encased with ABS and elastomer corner guards Optional hand strap or rotating hand strap Port covers Raised bezel for LCD impact protection Pre-installed replaceable screen film for LCD protection 														
CPU	<ul style="list-style-type: none"> Intel® Core™ i5-6300U vPro™ Processor ~ 2.4 GHz up to 3.0 GHz with Intel® Turbo Boost Technology Intel Smart Cache 3MB 														
STORAGE & MEMORY	<ul style="list-style-type: none"> 8GB DDR3L SDRAM^{4,5} 256GB solid state drive (SSD) with heater^{4,5} Optional 512GB ~ up to 64GB additional storage with optional microSDXC card slot 														
DISPLAY	<ul style="list-style-type: none"> 10.1" WUXGA 1920 x 1200 with LED backlighting 10-point capacitive multi touch + Waterproof Digitizer pen daylight-readable screen ~ 2-800 nit IPS display with direct bonding Anti-reflective and anti-glare screen treatments Ambient light sensor, digital compass, gyro and acceleration sensors Automatic screen rotation Intel® HD Graphics 520 (Built-in CPU) video controller Concealed mode (configurable) 														
AUDIO	<ul style="list-style-type: none"> Integrated microphone Realtek high-definition audio Integrated speaker On-screen and button volume and mute controls 														
KEYBOARD & INPUT	<ul style="list-style-type: none"> 10-point gloved multi touch + digitizer screen Supports bare-hand touch and gestures and electronic waterproof stylus pen Supports glove mode and wet-touch mode 7 tablet buttons (2 user-definable) Integrated stylus holder On-screen QWERTY keyboard 														
CAMERAS	<ul style="list-style-type: none"> 720p webcam with mic 8MP rear camera with autofocus and LED light 														
EXPANSION	<ul style="list-style-type: none"> Optional microSDXC3 														
INTERFACE	<table border="0"> <tr> <td>Docking connector</td> <td>24-pin</td> </tr> <tr> <td>HDMI</td> <td>Type A</td> </tr> <tr> <td>Headphones/speaker</td> <td>Mini-jack stereo</td> </tr> <tr> <td>Optional Serial Dongle¹</td> <td>D-sub 9-pin</td> </tr> <tr> <td>USB 3.0 (x 1)²</td> <td>4-pin</td> </tr> <tr> <td>Optional second USB 2.0³</td> <td>4-pin</td> </tr> <tr> <td>Optional 10/100/1000 Ethernet³</td> <td>RJ-45</td> </tr> </table>	Docking connector	24-pin	HDMI	Type A	Headphones/speaker	Mini-jack stereo	Optional Serial Dongle ¹	D-sub 9-pin	USB 3.0 (x 1) ²	4-pin	Optional second USB 2.0 ³	4-pin	Optional 10/100/1000 Ethernet ³	RJ-45
Docking connector	24-pin														
HDMI	Type A														
Headphones/speaker	Mini-jack stereo														
Optional Serial Dongle ¹	D-sub 9-pin														
USB 3.0 (x 1) ²	4-pin														
Optional second USB 2.0 ³	4-pin														
Optional 10/100/1000 Ethernet ³	RJ-45														
WIRELESS	<ul style="list-style-type: none"> Optional integrated 4G LTE multi carrier mobile broadband with satellite GPS Optional GPS (u-blox NEO M8N)⁴ Intel® Dual Band Wireless-AC 8260 (IEEE802.11a/b/g/n/ac) Bluetooth v4.1, Classic mode/Low Energy mode, Class 1 (Windows 10 pro 64-bit) Security <ul style="list-style-type: none"> Authentication: LEAP, WPA, 802.1x, EAP-TLS, EAP-FAST, PEAP Encryption: CKIP, TKIP, 128-bit and 64-bit WEP, Hardware AES Dual high-gain antenna pass-through 														
POWER SUPPLY	<ul style="list-style-type: none"> Li-ion battery pack: <ul style="list-style-type: none"> Standard battery: Li-ion 11.1 V, 4200 mAh (typ.), 4080 mAh (min.) Optional long life battery⁵: Li-ion 10.8V, 9300mAh(typ.), 8700mAh (min.) Battery operation⁶: <ul style="list-style-type: none"> Standard battery: 14 hours Optional long life battery⁵: 28 hours Battery charging time⁶: <ul style="list-style-type: none"> Standard battery: 2.5 hours off, 3 hours on Optional long life battery⁵: 3 hours off, 4 hours on Optional bridge battery⁷ (1 minute swap time) 														
POWER MANAGEMENT	<ul style="list-style-type: none"> Suspend/Resume Function, Hibernation, Standby 														
SECURITY FEATURES	<ul style="list-style-type: none"> Password Security: Supervisor, User, Hard Disk Lock Kensington cable lock slot Trusted platform module (TPM) security chip v2.0¹⁰ CompuTrace[®] theft protection agent in BIOS⁸ Optional Insertable SmartCard reader⁹ Optional Contactless SmartCard/HF RFID reader⁹ ISO 15693 and 14443 A/B compliant 														

WARRANTY	<ul style="list-style-type: none"> 3-year limited warranty, parts and labor 																																																						
DIMENSIONS & WEIGHT	<ul style="list-style-type: none"> 10.6" (L) x 7.4" (W) x 0.8" (H) 2.4 lbs. (standard battery) 3.0 lbs. (optional long life battery)¹ 																																																						
INTEGRATED OPTIONS⁸	<ul style="list-style-type: none"> 4G LTE multi carrier mobile broadband with satellite GPS Choice of 1D/2D barcode reader (EA11 or EA21), GPS, Serial Dongle, Ethernet, MicroSDXC or second USB 2.0 port³ Choice of bridge battery, magstripe reader, insertable SmartCard reader, insertable SmartCard reader with bridge battery, contactless SmartCard/RFID HF reader or UHF 900MHz RFID reader (EPC Gen 2)¹¹ 																																																						
ACCESSORIES⁹	<table border="0"> <tr> <td>AC Adapter (3-prong)</td> <td>CF-AA6413CM</td> </tr> <tr> <td>Standard Battery Pack</td> <td>FZ-VSU864ZU</td> </tr> <tr> <td>Long Life Battery Pack⁵</td> <td>FZ-VSU88U</td> </tr> <tr> <td>Long Life Battery Bundle (includes rotating hand strap and corner guard set)</td> <td>FZ-BNDL01115T1CG4</td> </tr> <tr> <td>Single Battery Charger Bundle</td> <td>FZ-BNDL01BATCHR</td> </tr> <tr> <td>LIND 3-Bay Battery Charger</td> <td>FZ-LND3BAG1</td> </tr> <tr> <td>LIND Car Adapter 120W</td> <td>CF-LNDCC120</td> </tr> <tr> <td>LIND Car/AC Adapter 90W (with USB port)</td> <td>CF-LNDACC90</td> </tr> <tr> <td>LIND Car Adapter 90W MIL-STD</td> <td>CF-LNDMLC90</td> </tr> <tr> <td>Tall Corner Guard Set</td> <td>FZ-WCGG111</td> </tr> <tr> <td>Rotating Hand Strap and Tall Corner Guard Set Bundle</td> <td>FZ-BNDL01ST1CG4</td> </tr> <tr> <td>ToughMate G1 Always-On Case (with hand strap)</td> <td>TBCG1AGNL-P</td> </tr> <tr> <td>ToughMate G1 Professional Portfolio</td> <td>TBCG1PFLD-BLK-P</td> </tr> <tr> <td>ToughMate G1 X Hand Strap</td> <td>TBCG1XSTP-P</td> </tr> <tr> <td>Desktop Cradle</td> <td>FZ-VEBG11AU</td> </tr> <tr> <td>Vehicle Docks (no pass-through)</td> <td></td> </tr> <tr> <td>- Gamber-Johnson</td> <td>7160-0486-00-P</td> </tr> <tr> <td>- Havis with LIND power supply</td> <td>CF-H-PAN-702-P</td> </tr> <tr> <td>Vehicle Docks (dual pass-through)</td> <td></td> </tr> <tr> <td>- Gamber-Johnson</td> <td>7160-0486-02-P</td> </tr> <tr> <td>- Havis with LIND power supply</td> <td>CF-H-PAN-702-2-P</td> </tr> <tr> <td>Cradlepoint Router</td> <td></td> </tr> <tr> <td>- Verizon</td> <td>CP-IBR1100LPE-VZ</td> </tr> <tr> <td>- AT&T</td> <td>CP-IBR1100LPE-AT</td> </tr> <tr> <td>Replacement Digitizer Pen Waterproof</td> <td>FZ-VNPG11U-S</td> </tr> <tr> <td>Tether</td> <td>FZ-VNTG11U</td> </tr> <tr> <td>10.1" LCD Protective Film</td> <td>FZ-VFPG11U</td> </tr> </table>	AC Adapter (3-prong)	CF-AA6413CM	Standard Battery Pack	FZ-VSU864ZU	Long Life Battery Pack ⁵	FZ-VSU88U	Long Life Battery Bundle (includes rotating hand strap and corner guard set)	FZ-BNDL01115T1CG4	Single Battery Charger Bundle	FZ-BNDL01BATCHR	LIND 3-Bay Battery Charger	FZ-LND3BAG1	LIND Car Adapter 120W	CF-LNDCC120	LIND Car/AC Adapter 90W (with USB port)	CF-LNDACC90	LIND Car Adapter 90W MIL-STD	CF-LNDMLC90	Tall Corner Guard Set	FZ-WCGG111	Rotating Hand Strap and Tall Corner Guard Set Bundle	FZ-BNDL01ST1CG4	ToughMate G1 Always-On Case (with hand strap)	TBCG1AGNL-P	ToughMate G1 Professional Portfolio	TBCG1PFLD-BLK-P	ToughMate G1 X Hand Strap	TBCG1XSTP-P	Desktop Cradle	FZ-VEBG11AU	Vehicle Docks (no pass-through)		- Gamber-Johnson	7160-0486-00-P	- Havis with LIND power supply	CF-H-PAN-702-P	Vehicle Docks (dual pass-through)		- Gamber-Johnson	7160-0486-02-P	- Havis with LIND power supply	CF-H-PAN-702-2-P	Cradlepoint Router		- Verizon	CP-IBR1100LPE-VZ	- AT&T	CP-IBR1100LPE-AT	Replacement Digitizer Pen Waterproof	FZ-VNPG11U-S	Tether	FZ-VNTG11U	10.1" LCD Protective Film	FZ-VFPG11U
AC Adapter (3-prong)	CF-AA6413CM																																																						
Standard Battery Pack	FZ-VSU864ZU																																																						
Long Life Battery Pack ⁵	FZ-VSU88U																																																						
Long Life Battery Bundle (includes rotating hand strap and corner guard set)	FZ-BNDL01115T1CG4																																																						
Single Battery Charger Bundle	FZ-BNDL01BATCHR																																																						
LIND 3-Bay Battery Charger	FZ-LND3BAG1																																																						
LIND Car Adapter 120W	CF-LNDCC120																																																						
LIND Car/AC Adapter 90W (with USB port)	CF-LNDACC90																																																						
LIND Car Adapter 90W MIL-STD	CF-LNDMLC90																																																						
Tall Corner Guard Set	FZ-WCGG111																																																						
Rotating Hand Strap and Tall Corner Guard Set Bundle	FZ-BNDL01ST1CG4																																																						
ToughMate G1 Always-On Case (with hand strap)	TBCG1AGNL-P																																																						
ToughMate G1 Professional Portfolio	TBCG1PFLD-BLK-P																																																						
ToughMate G1 X Hand Strap	TBCG1XSTP-P																																																						
Desktop Cradle	FZ-VEBG11AU																																																						
Vehicle Docks (no pass-through)																																																							
- Gamber-Johnson	7160-0486-00-P																																																						
- Havis with LIND power supply	CF-H-PAN-702-P																																																						
Vehicle Docks (dual pass-through)																																																							
- Gamber-Johnson	7160-0486-02-P																																																						
- Havis with LIND power supply	CF-H-PAN-702-2-P																																																						
Cradlepoint Router																																																							
- Verizon	CP-IBR1100LPE-VZ																																																						
- AT&T	CP-IBR1100LPE-AT																																																						
Replacement Digitizer Pen Waterproof	FZ-VNPG11U-S																																																						
Tether	FZ-VNTG11U																																																						
10.1" LCD Protective Film	FZ-VFPG11U																																																						

Please consult your reseller or Panasonic representative before purchasing.

Caution: Do not expose bare skin to this product when handling this unit in extreme hot or cold environments.

¹ Approximate time. Battery operation and recharge times will vary based on many factors, including screen brightness, applications, features, power management, battery conditioning and other customer preferences. Battery testing results from MobileMark 2007.

² Bridge battery, magstripe reader, insertable SmartCard reader, insertable SmartCard reader with bridge battery, contactless SmartCard reader and UHF RFID reader are mutually exclusive. Please note, USB 3.0 port cannot be accessed when the unit is equipped with the magstripe reader, but optional USB 2.0 port can be accessed.

³ GPS, Serial Dongle, Ethernet, MicroSDXC and second USB port are mutually exclusive options.

⁴ 1GB = 1,000,000,000 bytes.

⁵ Total usable memory will be less depending upon actual system configuration.

⁶ The size of the VRAM cannot be set by the user and varies by operating system as well as the size of the RAM. Windows 7 max. VRAM is 1555MB.

⁷ Magstripe reader, insertable SmartCard reader, insertable SmartCard reader with bridge battery and UHF RFID reader include full corner guards and rotating hand strap. Bridge battery (without SmartCard reader) includes medium corner guards and rotating hand strap.

⁸ Requires software and activation to enable theft protection.

⁹ Length measurements do not include protrusions. Weight varies with options and digitizer pen.

¹⁰ Accessories and Integrated Options may vary depending on your configuration. Visit the Panasonic website for more accessories and details.

¹¹ Hazardous location certifications may not apply to all configurations. Consult your Panasonic representative for availability.

¹² TPM 1.2 available upon request - please contact your reseller or Panasonic representative.



1.800.662.3537
panasonic.com/toughpad/G1

Panasonic is constantly enhancing product specifications and accessories. Specifications subject to change without notice. Trademarks are property of their respective owners. ©2018 Panasonic Corporation of North America. All rights reserved. Toughpad FZ-G1 m43 Spec Sheet_01/18

APPENDIX 1.4: CAMERA EQUIPMENT (CANON 5D MARK IV)



Canon
EOS 5D Mark IV

APPENDIX 1.4: CAMERA EQUIPMENT (SIGMA 50mm f/1.4)



A Art
50mm F1.4 DG HSM

+ Design detail



Incredible resolution ideal for the high-megapixel era. Introducing the new benchmark large-aperture standard lens

In 2008, Sigma released a large diameter standard lens designed for digital SLRs, "SIGMA 50mm F1.4 EX DG HSM". At that time, products for film cameras were prevalent, yet we spent enormous effort to set a new benchmark for the 50mm lens that optimizes the characteristics of digital cameras, such as compensating peripheral brightness, controlling the point images in the corners, and improving the image drawing, not only around the focusing point, but also other areas in the image.

APPENDIX 1.4: CAMERA EQUIPMENT (MANFROTTO 303 SPH)



Manfrotto
INSTRUCTIONS
303SPH
SPHERICAL "VR" HEAD

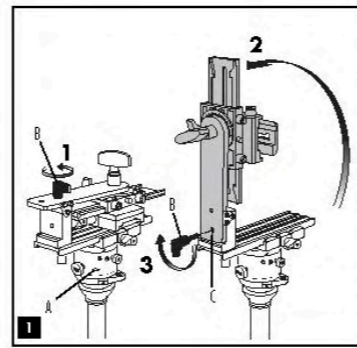

SET UP 1
Fix the leveling device (not supplied) to the tripod, then fix the "VR" head on the leveling device via knuckle attachment "M". Completely remove knob "B", rotate the bracket into the vertical position as shown in fig. 1 and lock it in place by screwing the knob "B" into hole "C".

The spherical "VR" head is designed to allow virtual scenes to be created by Computer from a various panoramic sequences of digital or digital photographs, taken at different vertical angles.

- There are 4 requirements to achieve good panoramic sequence shots:
1. Accurate leveling of the panoramic axis
 2. A Panoramic head that enables you to choose the angle of rotation between one shot and the next.
 3. The ability to position the camera on the "Nodal Point" of the lens (the front lens) is exactly above the panoramic axis of rotation, to eliminate any parallax problems between the near and distant objects in the scene.
 4. An additional rotating axis that enables you to shoot several panoramic sequences at different vertical angles in order to achieve a complete spherical scene.

The spherical "VR" head comprises three main modules that perform the functions mentioned above in points 2, 3 and 4.

Unless your tripod has a built-in leveling device (such as the Manfrotto A116's tripod's 5-ohm ball head), you will need to use one of the leveling accessories available from the Manfrotto range to ensure accurate leveling of the head (see point 1).

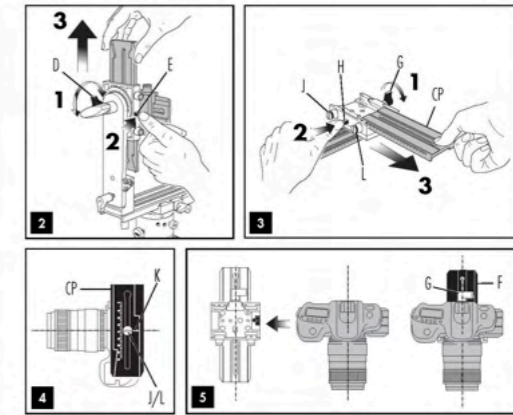

MOUNTING THE CAMERA 2 3 4 5
Remove the top assembly (fig. 2) by releasing knob "D". To slide it completely out of the housing, push safety button "E".
Remove camera plate "CP" (fig. 3) by releasing knob "G". To slide it completely out of the housing, push safety button "H".
You will find two screws attached to the top assembly: screw "I" (fig. 3) is 1/4 in; "L" is 5/8 in.
Depending on your camera tripod attachment, choose the correct screw and use it to fix your camera to plate "CP" (fig. 4). Use a coin or screwdriver to lock; take care to align the lens with the centre of the plate indicated by letter "K".
Mount the camera on the top assembly as shown in figure 5 by sliding the camera + plate into the housing following the direction shown by the "insert" arrow. Lock in place using knob "G", before locking, take care to align the lens with the long plate "F" - the lens axis must be perfectly above the slot of the plate as shown in figure 5.
The angle of the lever on the ratchet knob "C" can be repositioned as required without affecting the lock itself. Pull the lever outwards, rotate and release and it will locate in the new position.

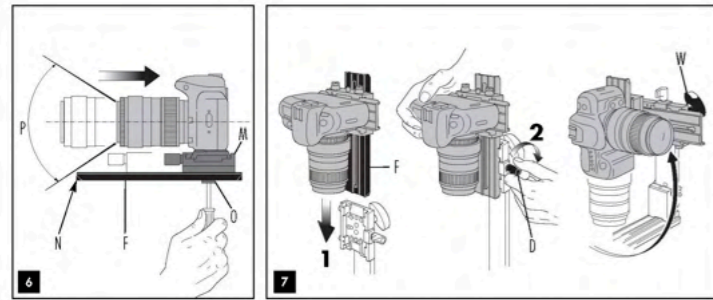

NOTE 6
The position of the housing "M" relative to the long plate "F" will need to be adjusted: loosen screw "O" to slide the housing. The ideal position is with the camera body as far back on the plate as it can go before the front edge "N" of the long plate "F" becomes visible in the camera's field of view "P".

MOUNT THE CAMERA ON THE HEAD 7
Mount the whole top assembly + camera on the head as shown in figure 7 by sliding the long plate "F" into its housing and locking it by screwing knob "D", then unscrew knob "W" and move the camera on the vertical plane.



ACCURATE POSITIONING OF THE "NODAL POINT" 8 9
Align the panoramic axis of rotation "M" (center "NODAL POINT" marking on plate "M" in photo) by housing the knob "V" and moving long plate "F" laterally. (Ref. Figure 9) Align the longitudinal plane by housing the knob "D" and adjusting the plate "F" until the front lens "L" is placed above the panoramic axis of rotation "M". At this point, the position is already able to handle VR panning of horizons or vertical shots.

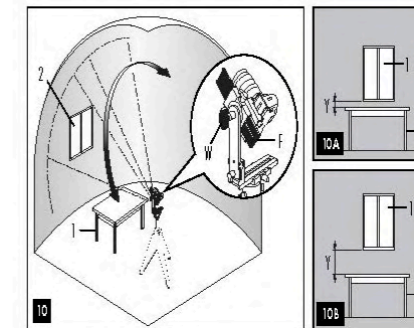

ACCURATE POSITIONING OF THE "NODAL POINT" 10
If the lens being shot contains objects at varying distance from the point where the shot is being taken (near and distant objects), the "Nodal Point" needs to be more accurately positioned as follows (the greater is possible ONLY with reflex camera):
- FIRST LATERAL POSITIONING ONLY THEN LONGITUDINAL POSITIONING HAS BEEN SET

LONGITUDINAL POSITIONING 10
(Ref. Figure 10) Choose a frame that contains both a near object "1" and a distant object "2" situated along the same vertical line of vision.
1. (See Figure 10A and 10B) unscrew knob "O" and move the camera on the vertical plane to bring the two objects first to the top and then to the bottom of the frame, checking whether the height gap "Y" between the two objects varies as the two frames the more constant the distance remains, the more accurately the "Nodal Point" has been positioned.
2. For optimum results, make minor adjustments by moving plate "F".
Once the right position is achieved it is VERY USEFUL to memorise it by noting the position of the plate "F" on the index on the graduated scale.

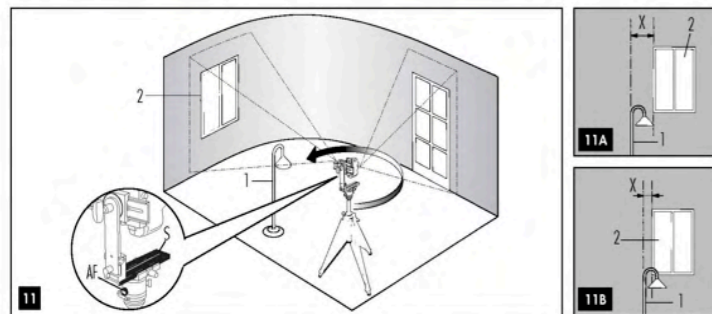

LATERAL POSITIONING 11
(Ref. Figure 11): Choose a frame that contains both a near object "1" and a distant object "2" situated along the same horizontal line of vision.
1. (See Figure 11A and 11B): unscrew knob "AF" and move the camera around the panoramic axis so that the two objects are first on the left hand side of the frame, then on the right. Check whether the horizontal gap "X" between the two objects varies in the two frames: the more constant the distance remains, the more accurately the "Nodal Point" has been positioned.
2. For optimum results, make minor adjustments by moving plate "S".

Once the right position is achieved it is VERY USEFUL to memorise it by noting the position of the plate "S" on the index on the graduated scale.

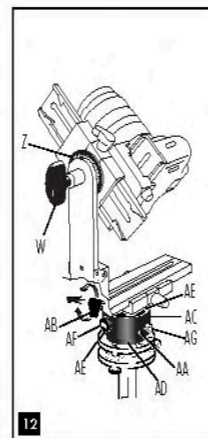

INSTRUCTIONS FOR SPHERICAL PANORAMIC SHOOTING 12

A special panoramic scene is obtained by adding together panoramic sequences taken at different angles from the horizontal. First you will need to choose the number of panoramic sequences you will need to complete the sphere depending on the angle of the lens you will be using. Before starting with the panoramic sequence, choose the initial vertical angle using the ratchet scale "Z" (fig. 12). Unscrew locking knob "AF" or remove it completely if you do not need it (it must be used to completely stop rotation when the head is used in non-vertical position, or to avoid any accidental movement of the head in any position).

Decide the number of shots or the angle of rotation between each shot for the first panoramic sequence (see the chart below).

Angle	90°	60°	45°	36°	30°	24°	20°	15°	10°	5°
n. shots	4	6	8	10	12	15	18	24	36	72

- Screw knob "AG" into the selected setting holes "AA".
- Release locking lever "AB" and rotate the camera on top plate "AE" to the position of the first shot.
- Hold the camera in position and rotate the control barrel "AC" until the first "click stop" is reached, then lock lever "AB".
- Take the first shot and then rotate the camera to the next "click stop" without releasing "AB" and take the next shot.

Continue the process until the start position is reached.

Once you have completed the first complete panoramic sequence, you can start on the other panoramic sequences needed to cover the sphere: change the vertical angle using knob "W" and ratchet scale "Z", and repeat the operations described above for each full sequence.

The base of the head "AD" has graduated scale markings from 0 to 360° and a reference index "AE" on the control barrel "AC". This is to be used to set angles out on the chart. To use the head in this way, release knob "AS" to disengage the "click stop" driving rotation of control barrel "AC" and use the locking knob "AW" to lock the position during shooting.

NOTE: The angle of the lever on the ratchet knob "AE" can be repositioned as required without affecting the lock itself. Pull the lever outwards, rotate as required and release and it will locate in the new position.

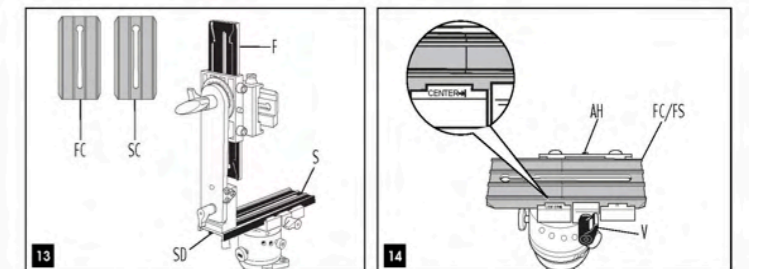

ADDITIONAL PLATES 13
If you have a very compact camera we suggest you to use the short plates "SC" (fig. 13) and "FC" (supplied with the head) instead of the two long plates "F" and "S" in order to reduce space and weight of the system.
To replace the plate "S" unscrew screw "SD" (fig. 13).
To replace the plate "F", please refer to fig. 6 and unscrew screw "O".

USE OF THE KIT AS AN OBJECT PANORAMA TURNABLE 14
The head can also be used as a turntable, useful for shooting object panoramas. For this use, loosen knob "V" and push button "AH" to slide the lower plate "S" out of the housing on the panoramic rotation base unit. In place of the long plate and top assembly, mount one of the two shorter plates supplied as a base for your object. The plate housing has a "center" mark to help you position your object accurately above the center of panoramic rotation.

Camera Location:

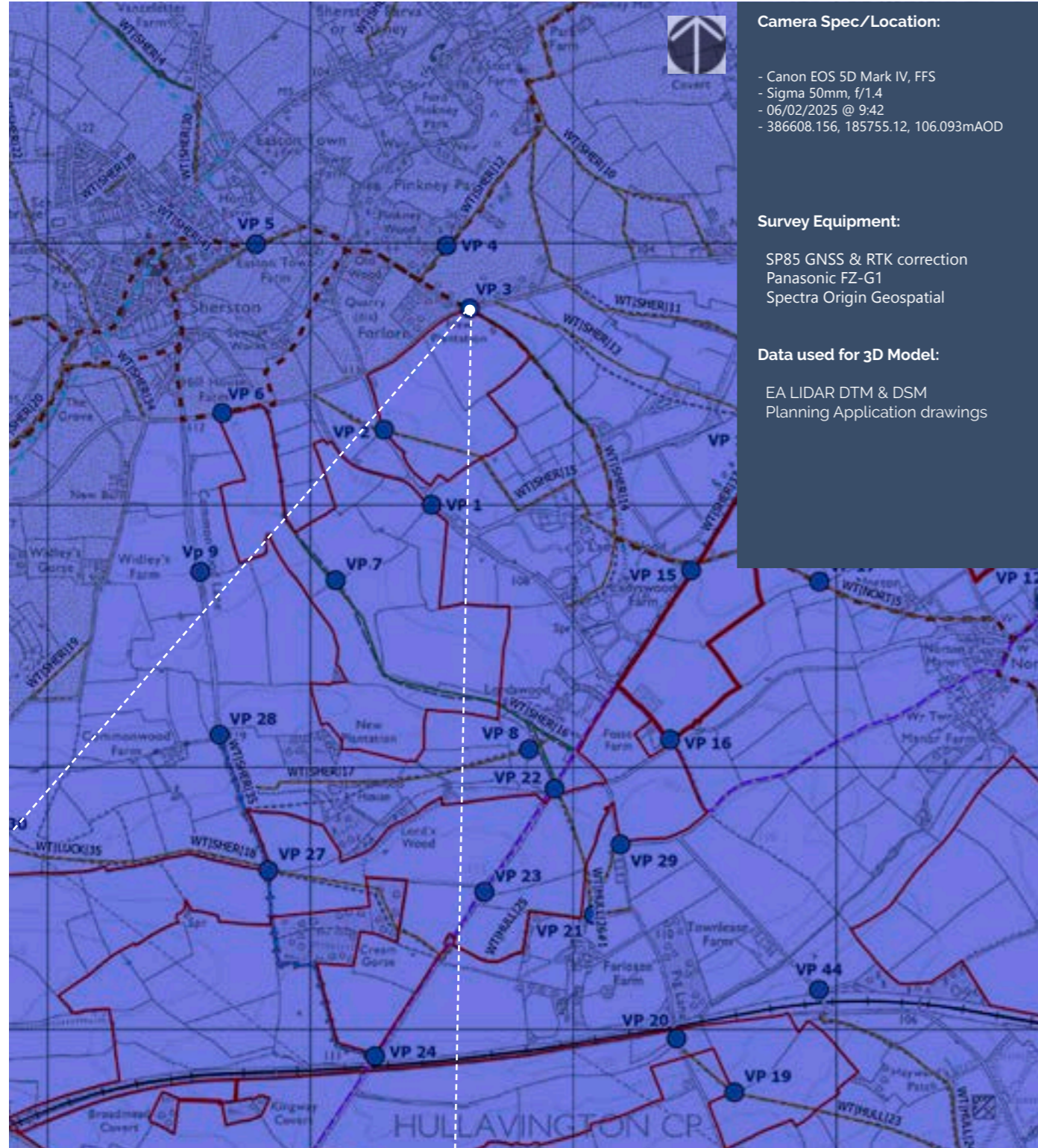

Corn Copyright and database rights 2025 Ordnance Survey 0100031673

Tripod:



50mm Lens Planar Projection (actual 49.6mm; 39.9 deg HFOV)



Point of Perspective

Viewpoint 3 Winter Single Frame 50mm Reference image

Limedown Solar Park

Camera Location:

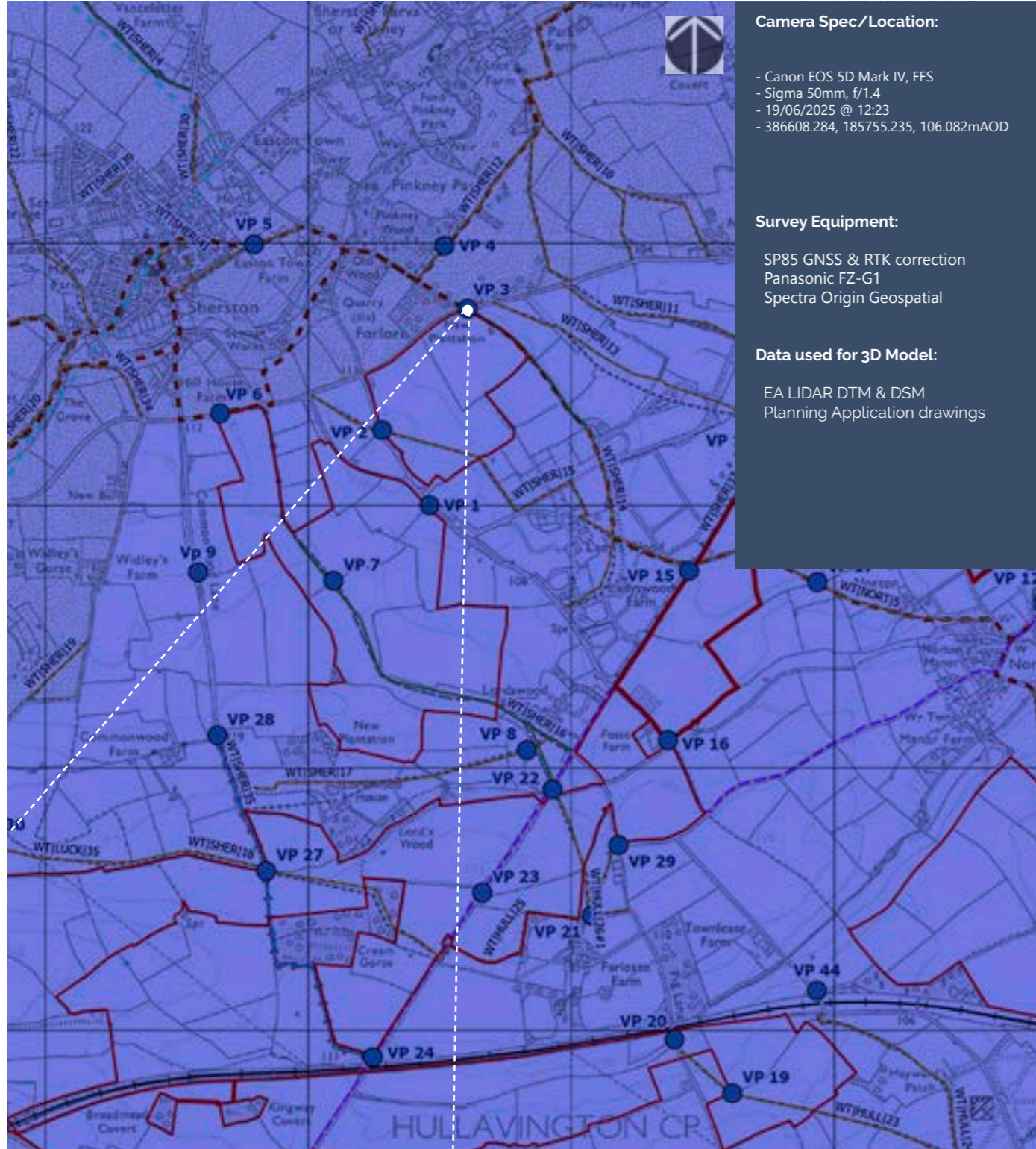

Camera Spec/Location:

- Canon EOS 5D Mark IV, FFS
- Sigma 50mm, f/1.4
- 19/06/2025 @ 12:23
- 386608.284, 185755.235, 106.082mAOD

Survey Equipment:

- SP85 GNSS & RTK correction
- Panasonic FZ-G1
- Spectra Origin Geospatial

Data used for 3D Model:

- EA LIDAR DTM & DSM
- Planning Application drawings

Corn Copyright and database rights 2025 Ordnance Survey 0100031673

Tripod:



50mm Lens Planar Projection (actual 49.6mm; 39.9 deg HFOV)



Point of Perspective

Point of Perspective

Point of Perspective

Point of Perspective

Viewpoint 3 Summer Single Frame 50mm Reference image

Camera Location:

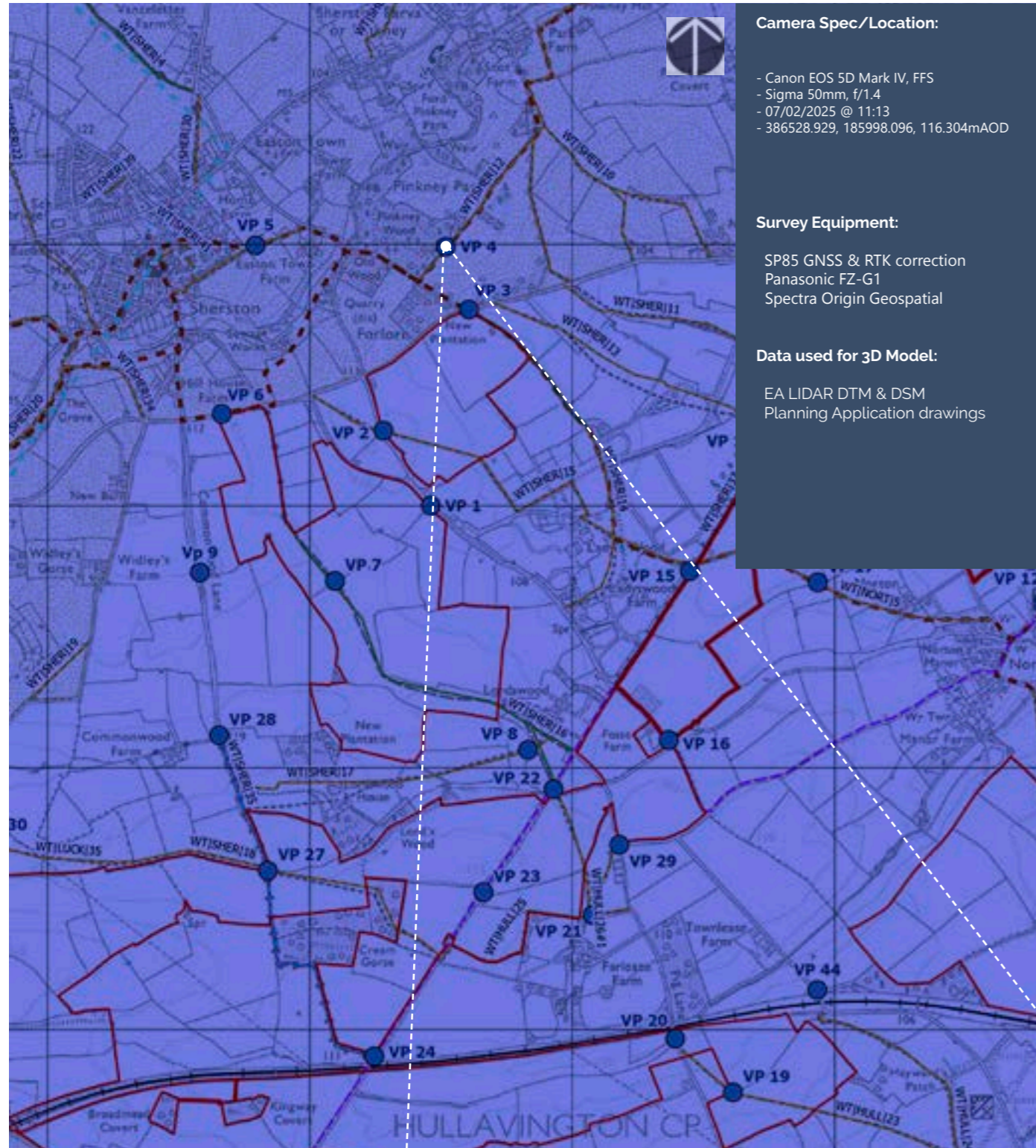

Camera Spec/Location:

- Canon EOS 5D Mark IV, FFS
- Sigma 50mm, f/1.4
- 07/02/2025 @ 11:13
- 386528.929, 185998.096, 116.304mAOD

Survey Equipment:

- SP85 GNSS & RTK correction
- Panasonic FZ-G1
- Spectra Origin Geospatial

Data used for 3D Model:

- EA LIDAR DTM & DSM
- Planning Application drawings

Corn Copyright and database rights 2025 Ordnance Survey 0100031673

Tripod:



50mm Lens Planar Projection (actual 49.6mm; 39.9 deg HFOV)



Point of Perspective

Point of Perspective

Point of Perspective

Point of Perspective

Viewpoint 4 Winter Single Frame 50mm Reference image

Camera Location:

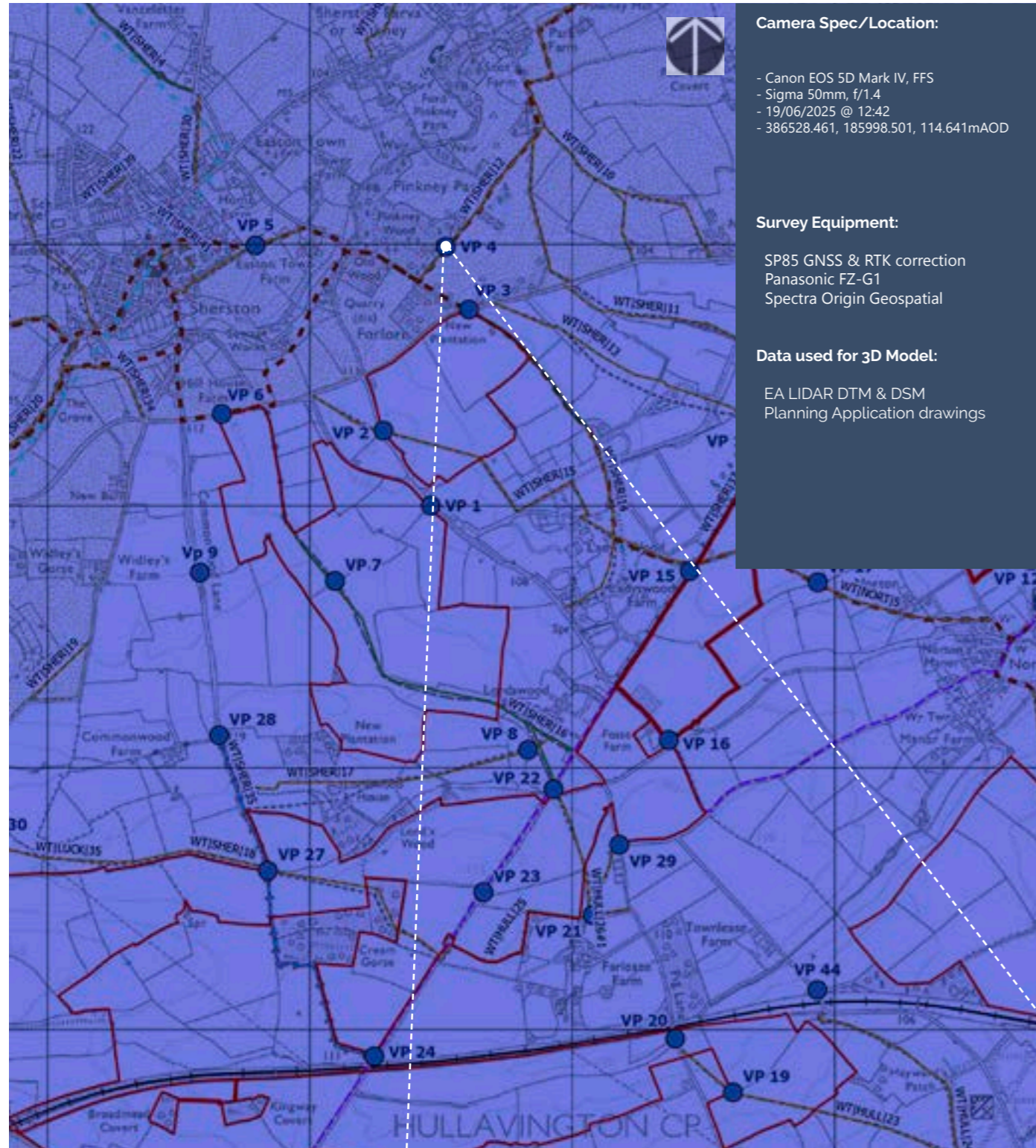

Corn Copyright and database rights 2025 Ordnance Survey 0100031673

Tripod:



50mm Lens Planar Projection (actual 49.6mm; 39.9 deg HFOV)

Point of Perspective



Point of Perspective

Point of Perspective

Point of Perspective

Viewpoint 4 Summer Single Frame 50mm Reference image

Camera Location:

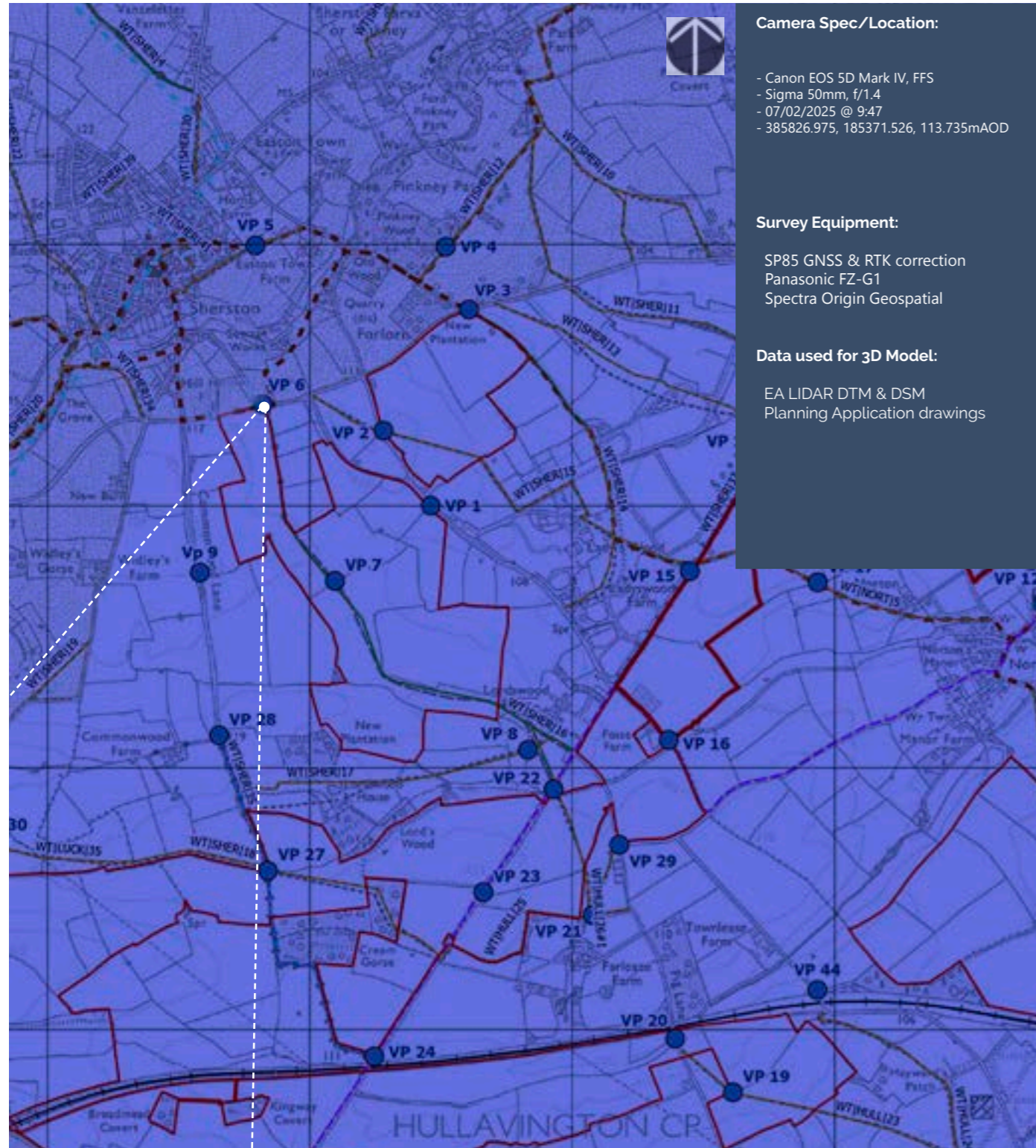

Camera Spec/Location:

- Canon EOS 5D Mark IV, FFS
- Sigma 50mm, f/1.4
- 07/02/2025 @ 9:47
- 385826.975, 185371.526, 113.735mAOD

Survey Equipment:

- SP85 GNSS & RTK correction
- Panasonic FZ-G1
- Spectra Origin Geospatial

Data used for 3D Model:

- EA LIDAR DTM & DSM
- Planning Application drawings

Corn Copyright and database rights 2025 Ordnance Survey 0100031673

Tripod:



50mm Lens Planar Projection (actual 49.6mm; 39.9 deg HFOV)



Point of Perspective

Point of Perspective

Point of Perspective

Point of Perspective

Viewpoint 6 Winter Single Frame 50mm Reference image

Camera Location:

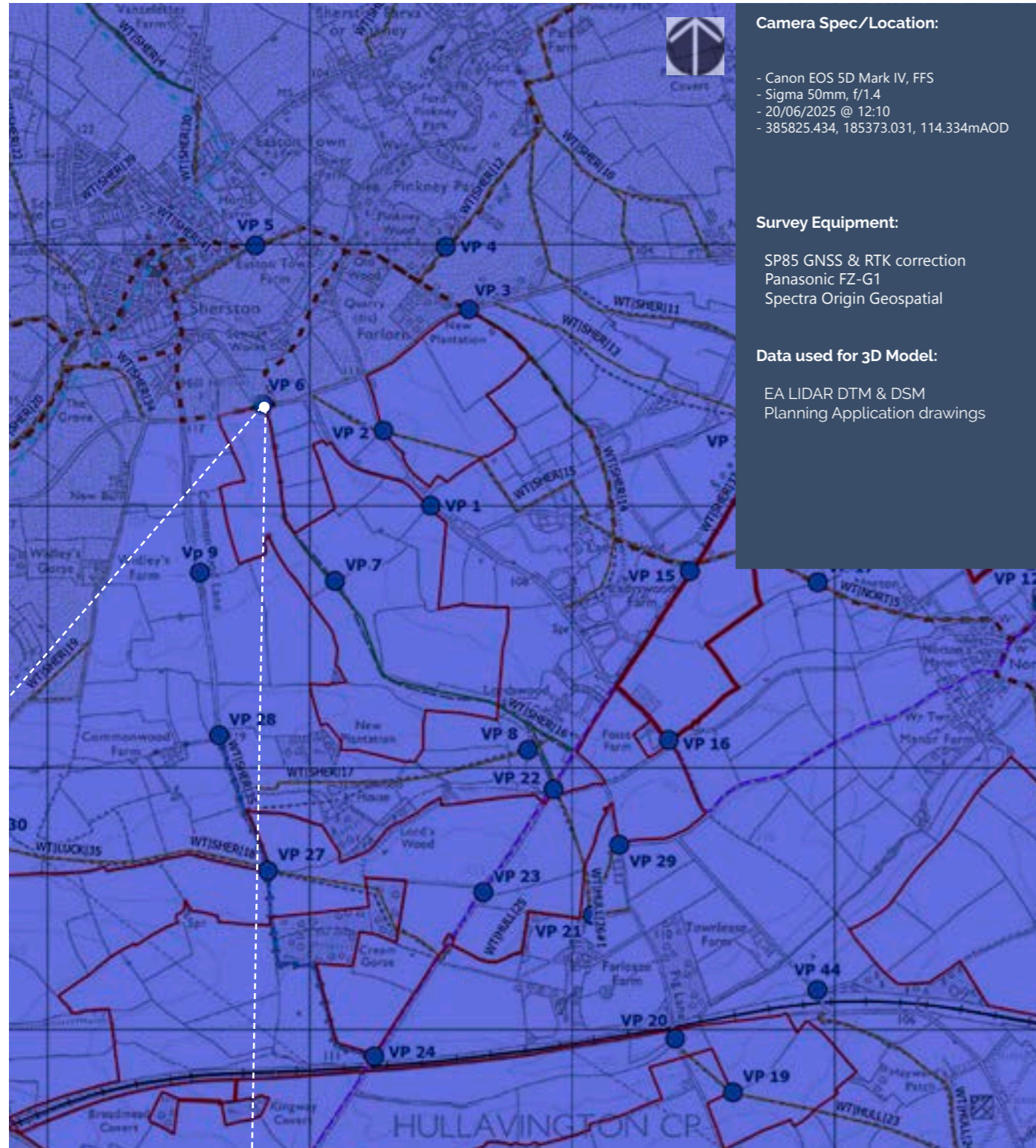

Camera Spec/Location:

- Canon EOS 5D Mark IV, FFS
- Sigma 50mm, f/1.4
- 20/06/2025 @ 12:10
- 385825.434, 185373.031, 114.334mAOD

Survey Equipment:

- SP85 GNSS & RTK correction
- Panasonic FZ-G1
- Spectra Origin Geospatial

Data used for 3D Model:

- EA LIDAR DTM & DSM
- Planning Application drawings

Corn Copyright and database rights 2025 Ordnance Survey 0100031673

Tripod:



50mm Lens Planar Projection (actual 49.6mm; 39.9 deg HFOV)

Point of Perspective



Point of Perspective

Point of Perspective

Point of Perspective

Viewpoint 6 Summer Single Frame 50mm Reference image

Camera Location:

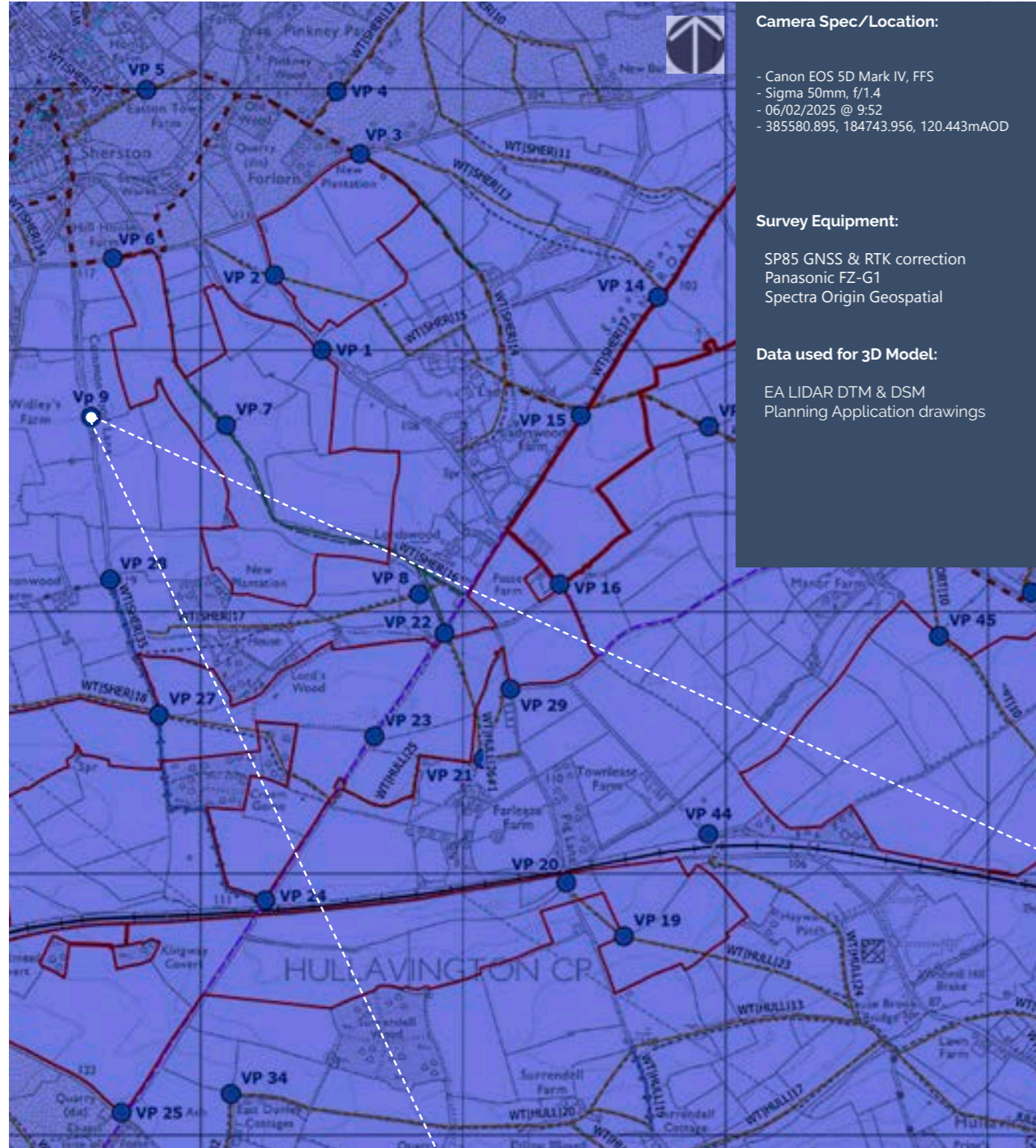

Camera Spec/Location:

- Canon EOS 5D Mark IV, FFS
- Sigma 50mm, f/1.4
- 06/02/2025 @ 9:52
- 385580.895, 184743.956, 120.443mAOD

Survey Equipment:

- SP85 GNSS & RTK correction
- Panasonic FZ-G1
- Spectra Origin Geospatial

Data used for 3D Model:

- EA LIDAR DTM & DSM
- Planning Application drawings

© Crown Copyright and database rights 2025 Ordnance Survey 0100031673

Tripod:



50mm Lens Planar Projection (actual 49.6mm; 39.9 deg HFOV)

Point of Perspective



Point of Perspective

Point of Perspective

Point of Perspective

Viewpoint 9 Winter Single Frame 50mm Reference image

Camera Location:

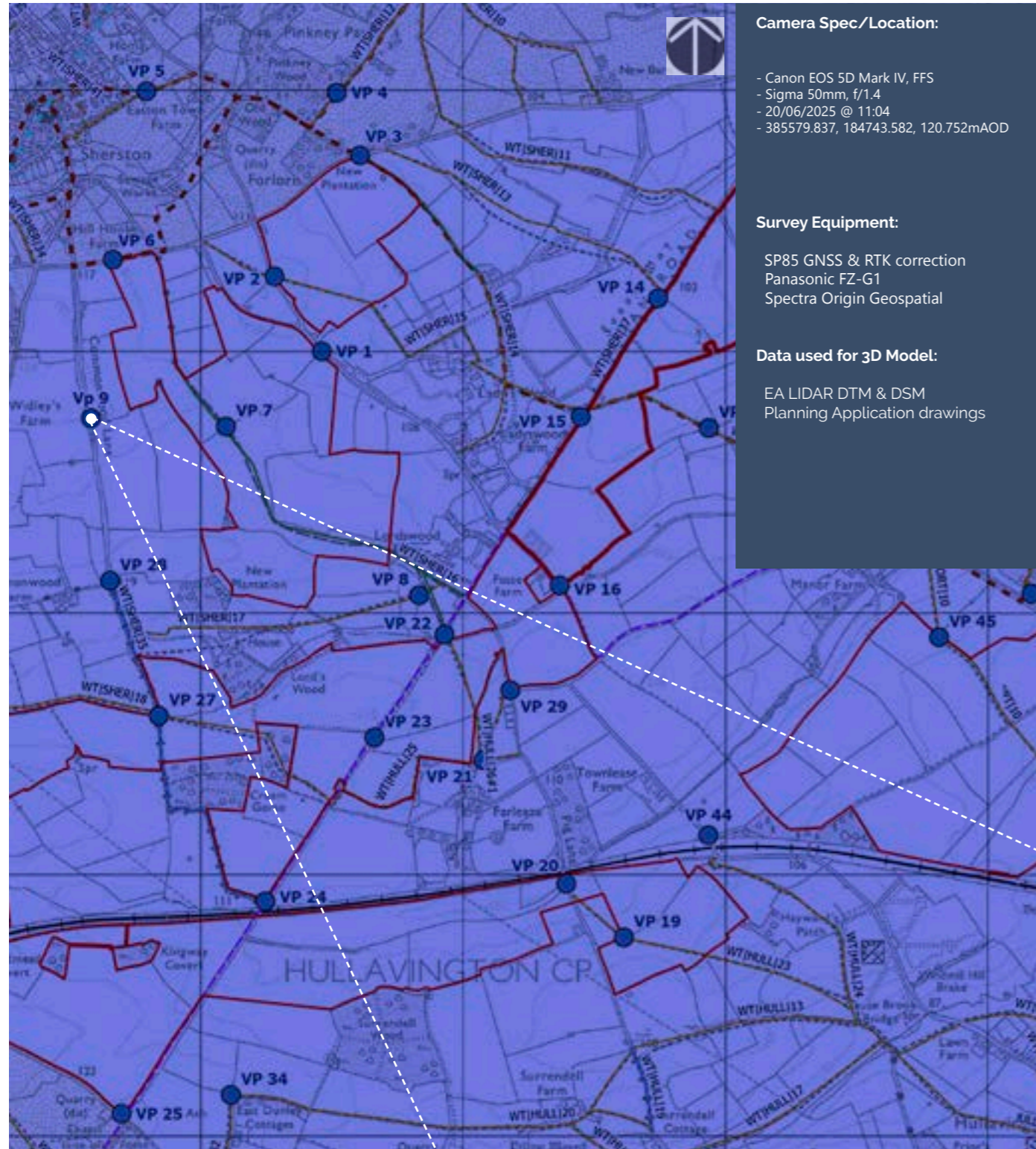

Tripod:



50mm Lens Planar Projection (actual 49.6mm; 39.9 deg HFOV)

Point of Perspective



Point of Perspective

Point of Perspective

Point of Perspective

Viewpoint 9 Summer Single Frame 50mm Reference image

Camera Location:

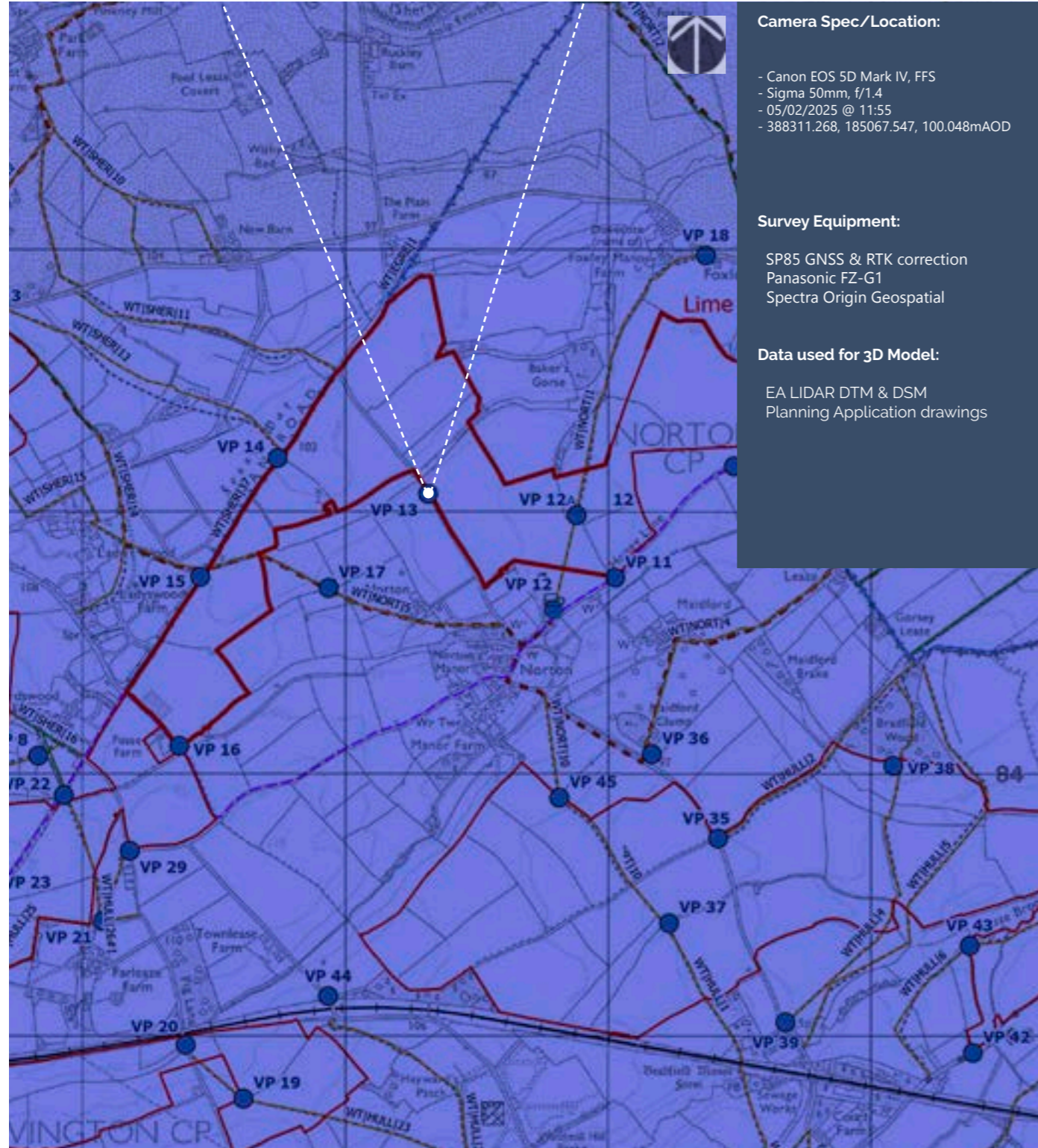

Camera Spec/Location:

- Canon EOS 5D Mark IV, FFS
- Sigma 50mm, f/1.4
- 05/02/2025 @ 11:55
- 388311.268, 185067.547, 100.048mAOD

Survey Equipment:

- SP85 GNSS & RTK correction
- Panasonic FZ-G1
- Spectra Origin Geospatial

Data used for 3D Model:

- EA LIDAR DTM & DSM
- Planning Application drawings

Ordnance Survey Crown Copyright and database rights 2025 Ordnance Survey 0100031673

Tripod:



50mm Lens Planar Projection (actual 49.6mm; 39.9 deg HFOV)

Point of Perspective



Point of Perspective

Point of Perspective

Point of Perspective

Viewpoint 13 Winter Single Frame 50mm Reference image

Limedown Solar Park

Camera Location:

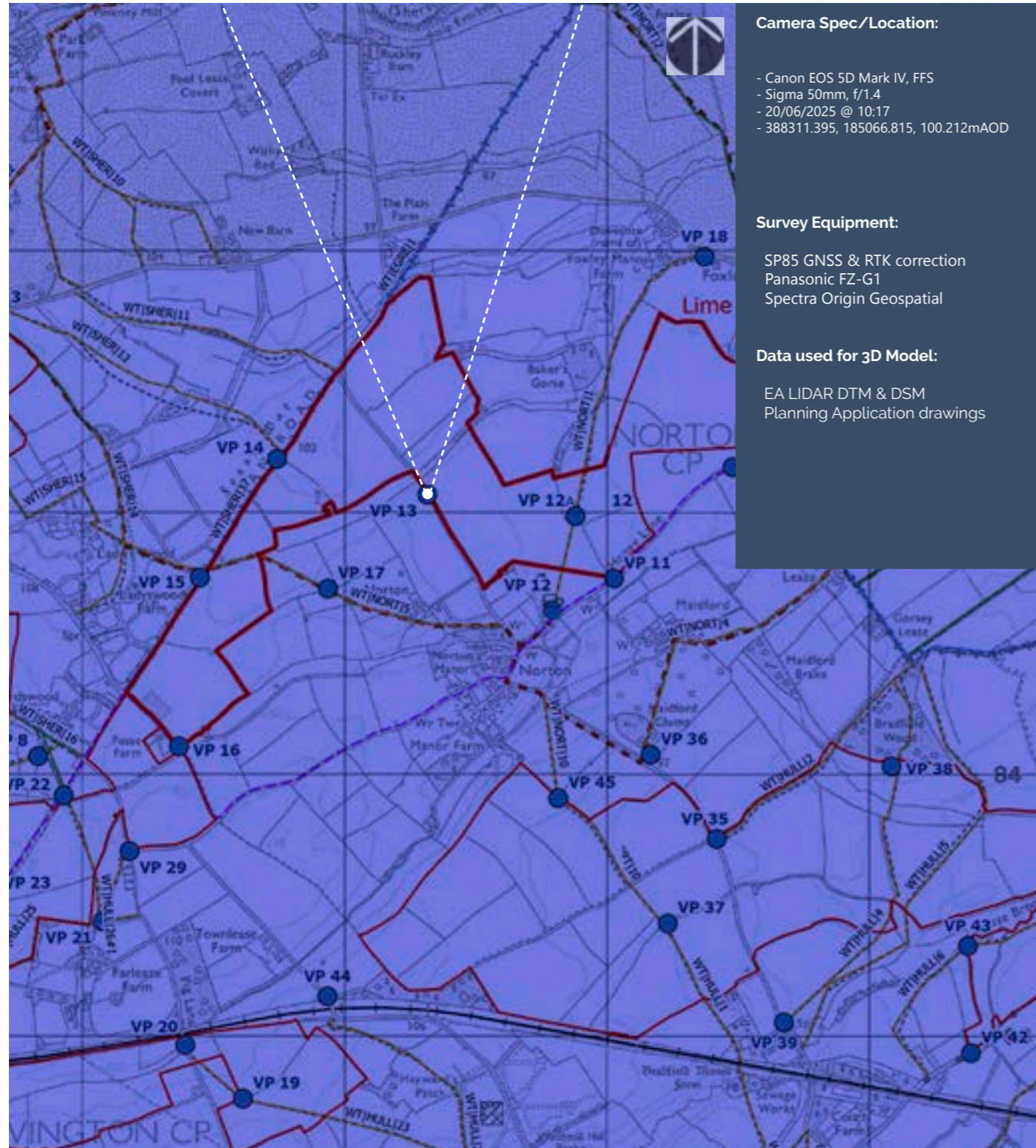

© Crown Copyright and database rights 2025 Ordnance Survey 0100031673

Tripod:



50mm Lens Planar Projection (actual 49.6mm; 39.9 deg HFOV)

Point of Perspective



Point of Perspective

Point of Perspective

Point of Perspective

Viewpoint 13 Summer Single Frame 50mm Reference image

Limedown Solar Park

Camera Location:

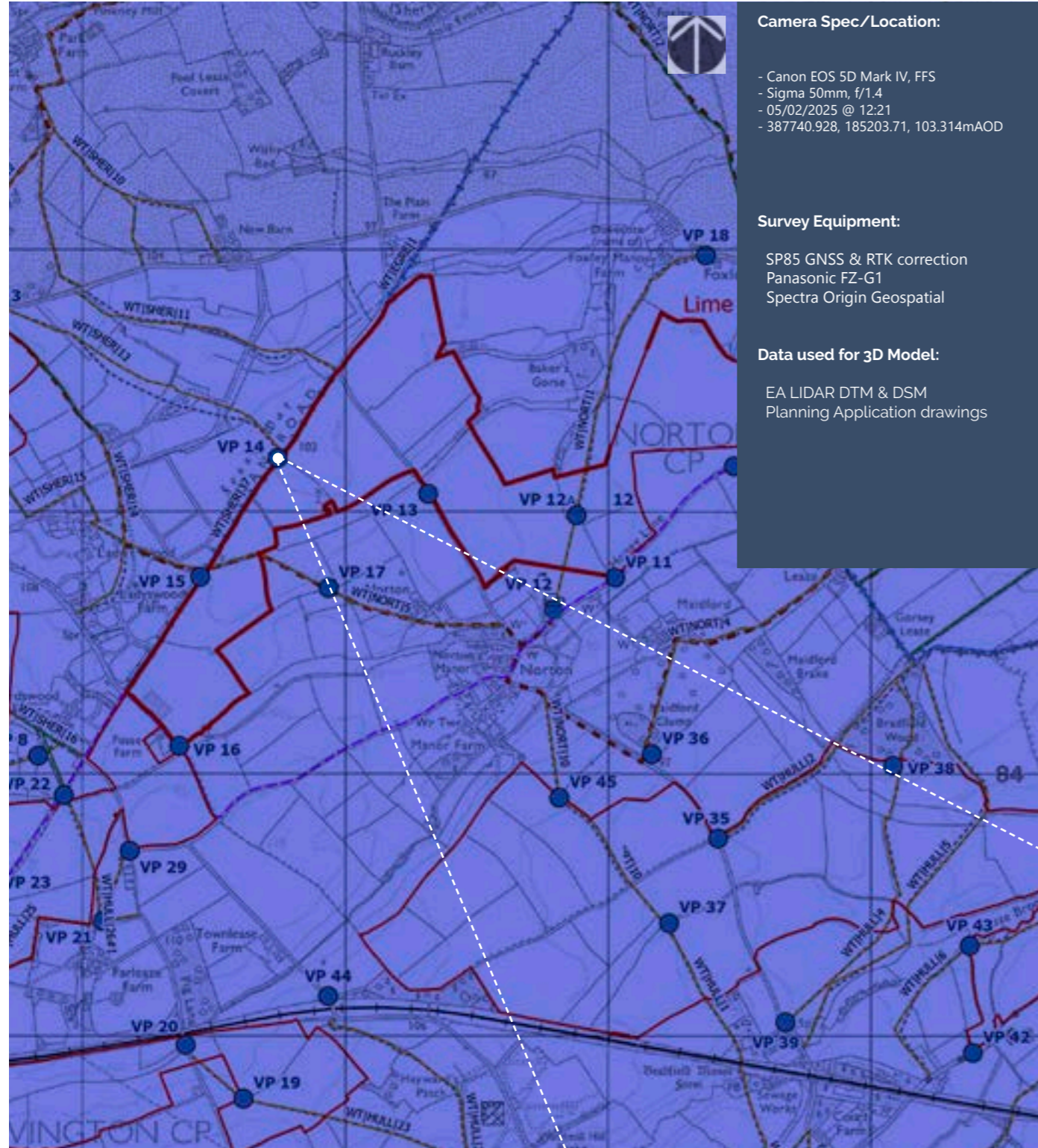

Ordnance Survey 0100031673

Tripod:



50mm Lens Planar Projection (actual 49.6mm; 39.9 deg HFOV)



Viewpoint 14 Winter Single Frame 50mm Reference image

Camera Location:

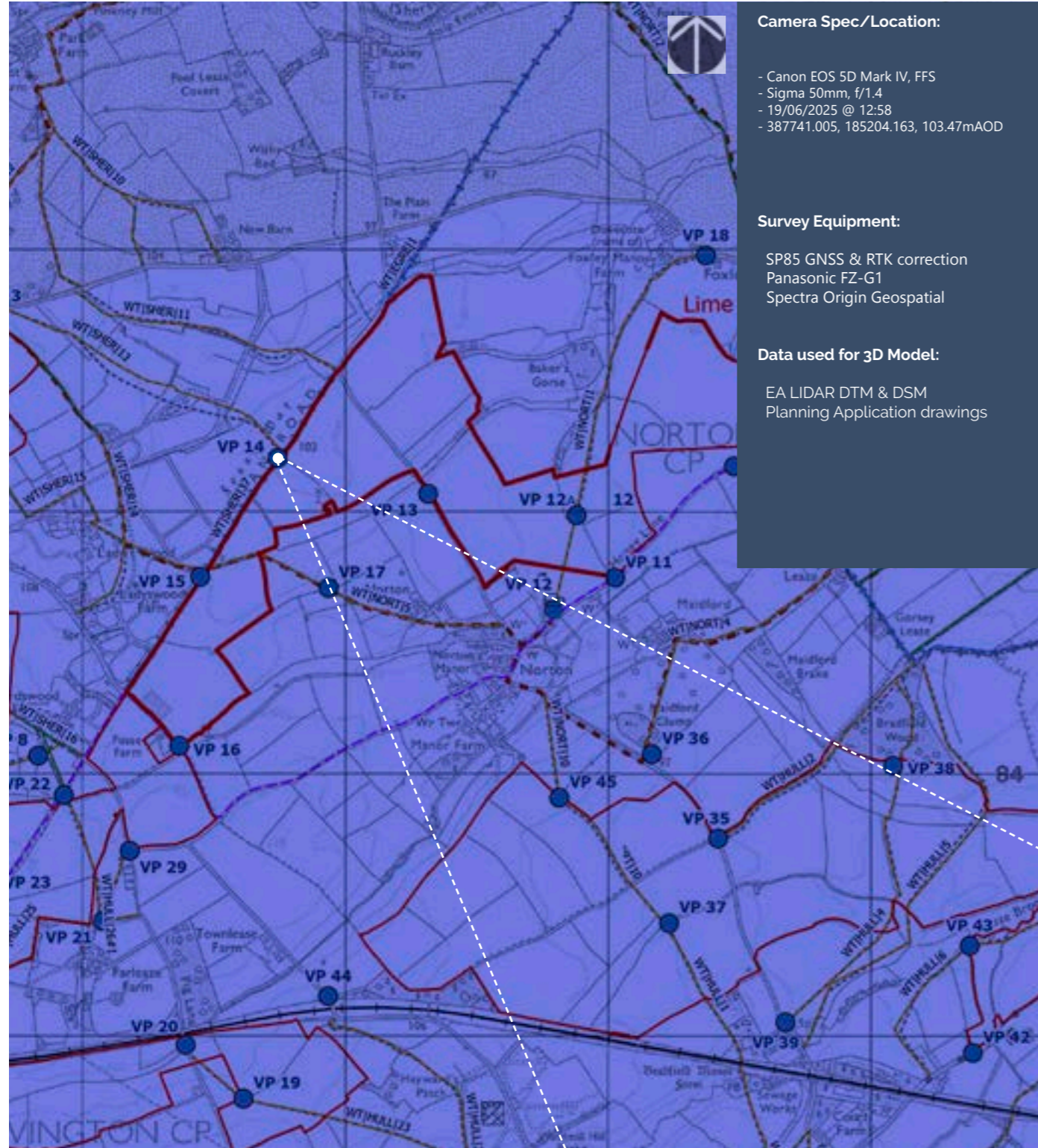

Camera Spec/Location:

- Canon EOS 5D Mark IV, FFS
- Sigma 50mm, f/1.4
- 19/06/2025 @ 12:58
- 387741.005, 185204.163, 103.47mAOD

Survey Equipment:

- SP85 GNSS & RTK correction
- Panasonic FZ-G1
- Spectra Origin Geospatial

Data used for 3D Model:

- EA LIDAR DTM & DSM
- Planning Application drawings

Ordnance Survey 0100031673

Tripod:



50mm Lens Planar Projection (actual 49.6mm; 39.9 deg HFOV)



Point of Perspective

Point of Perspective

Point of Perspective

Point of Perspective

Viewpoint 14 Summer Single Frame 50mm Reference image

Camera Location:

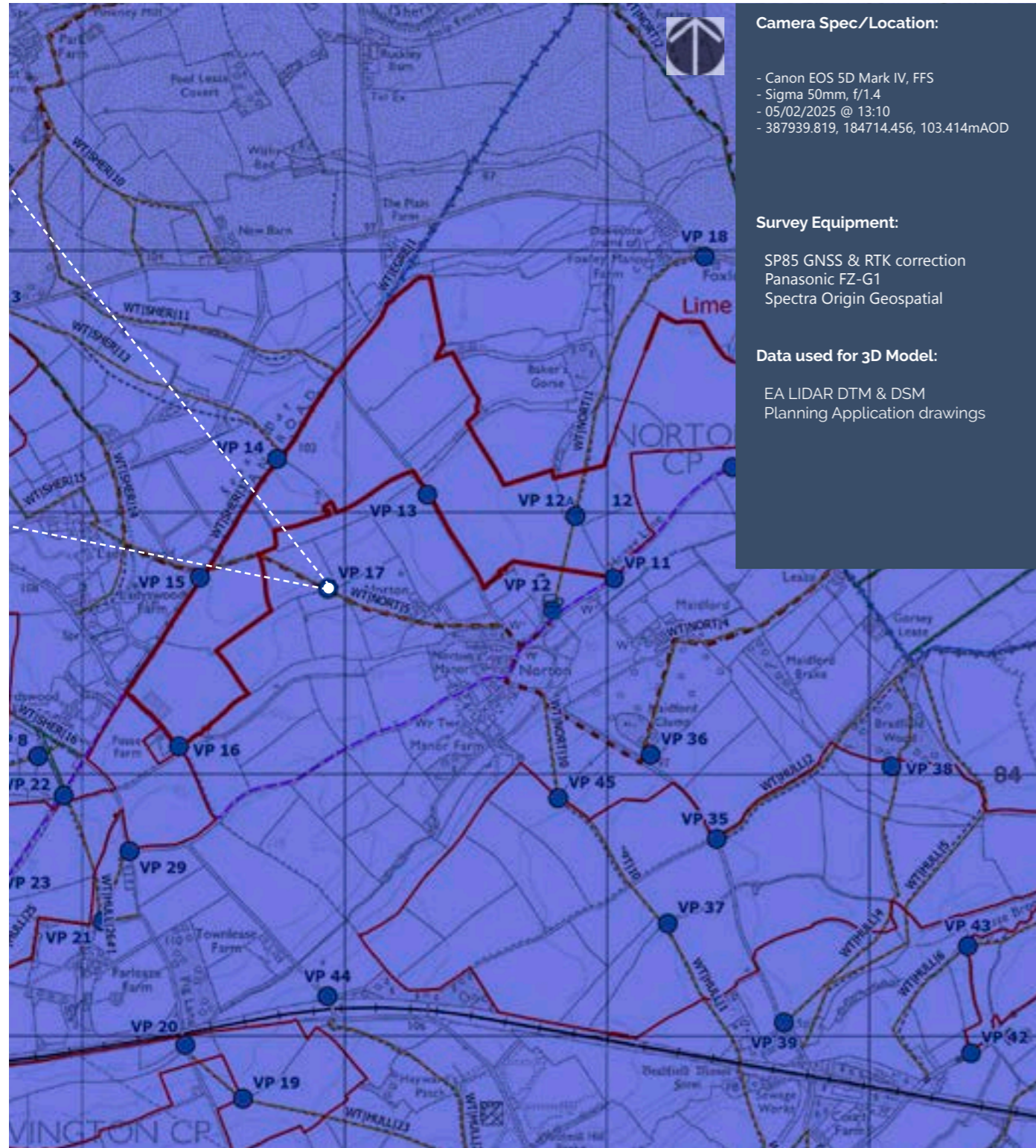

Ordnance Survey Crown Copyright and database rights 2025 Ordnance Survey 0100031673

Tripod:



50mm Lens Planar Projection (actual 49.6mm; 39.9 deg HFOV)



Point of Perspective

Point of Perspective

Point of Perspective

Point of Perspective

Viewpoint 17 Winter Single Frame 50mm Reference image

Camera Location:

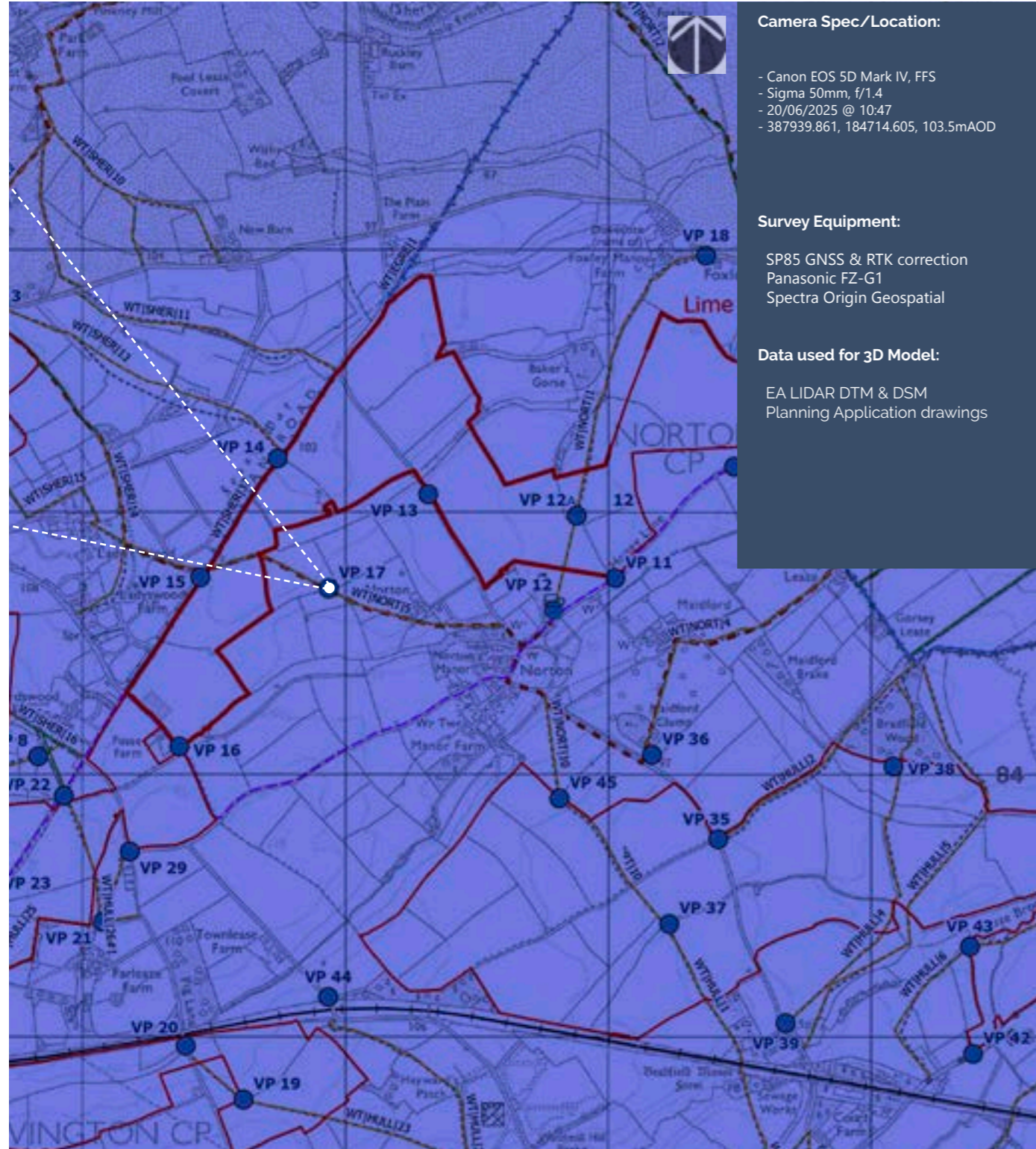

Ordnance Survey Crown Copyright and database rights 2025 Ordnance Survey 0100031673

Tripod:



50mm Lens Planar Projection (actual 49.6mm; 39.9 deg HFOV)



Point of Perspective

Point of Perspective

Point of Perspective

Point of Perspective

Viewpoint 17 Summer Single Frame 50mm Reference image

Camera Location:

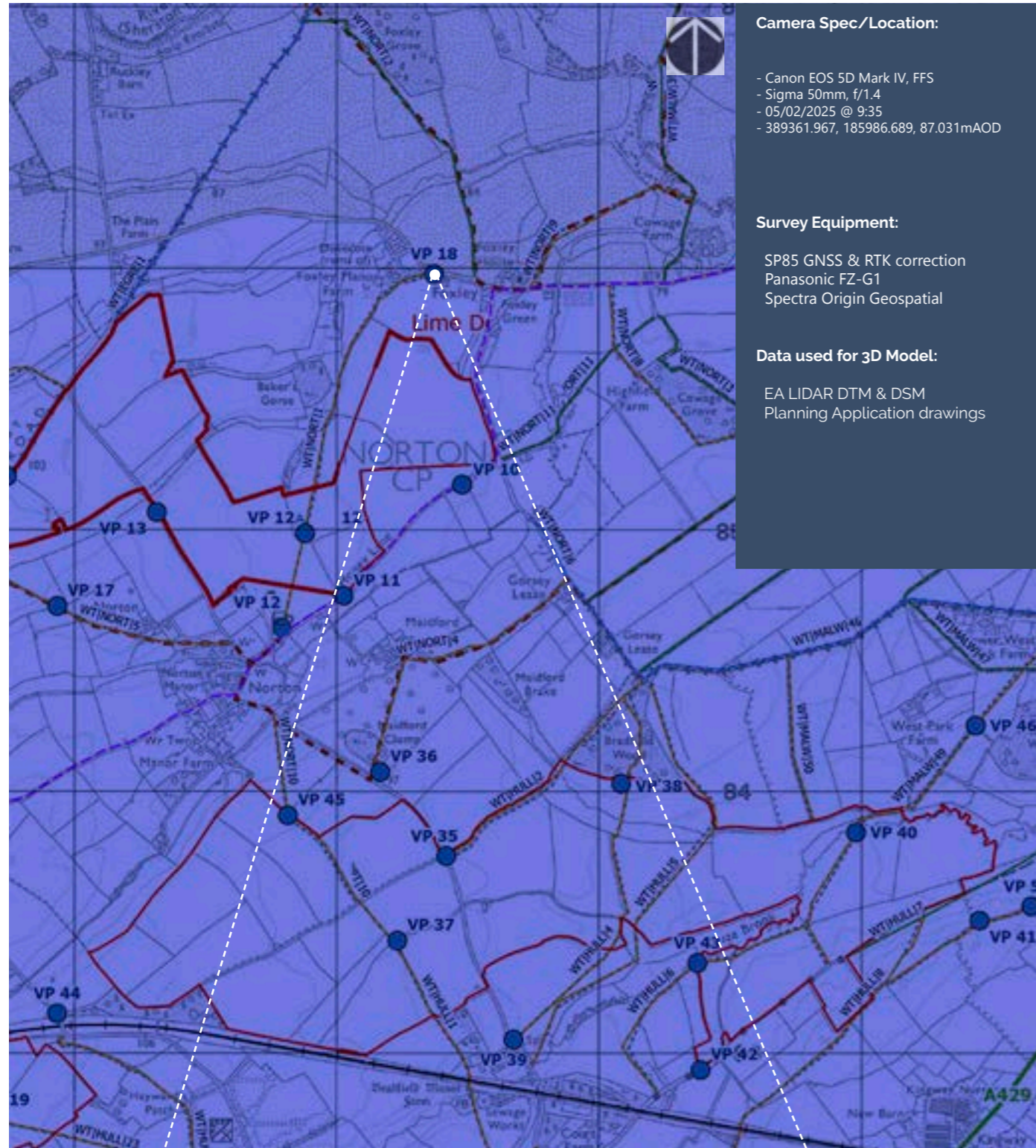

Crown Copyright and database rights 2025 Ordnance Survey 0100031673

Tripod:



50mm Lens Planar Projection (actual 49.6mm; 39.9 deg HFOV)



Point of Perspective

Viewpoint 18 Winter Single Frame 50mm Reference image

Camera Location:

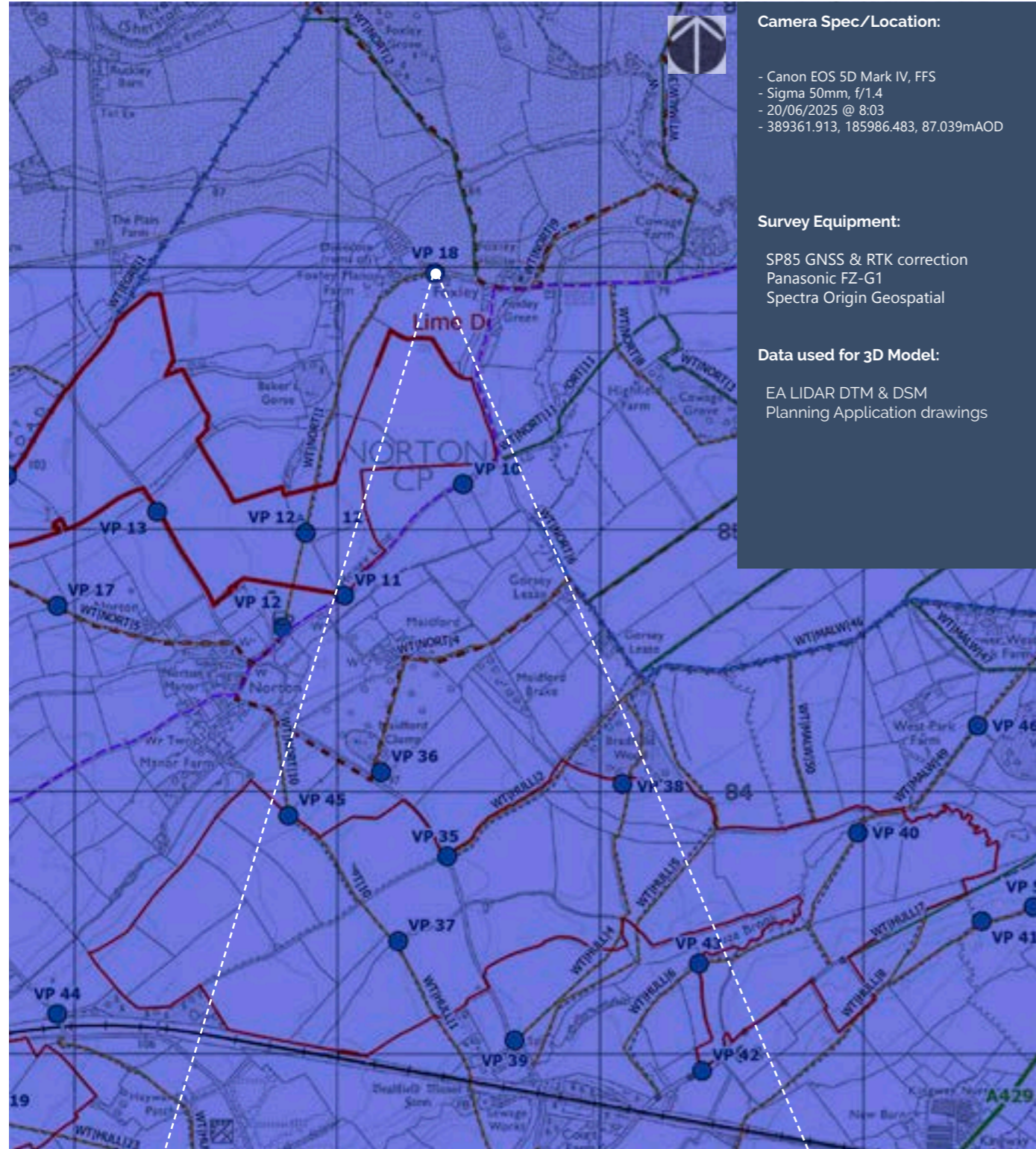

Camera Spec/Location:

- Canon EOS 5D Mark IV, FFS
- Sigma 50mm, f/1.4
- 20/06/2025 @ 8:03
- 389361.913, 185986.483, 87.039mAOD

Survey Equipment:

- SP85 GNSS & RTK correction
- Panasonic FZ-G1
- Spectra Origin Geospatial

Data used for 3D Model:

- EA LIDAR DTM & DSM
- Planning Application drawings

Crown Copyright and database rights 2025 Ordnance Survey 0100031673

Tripod:



50mm Lens Planar Projection (actual 49.6mm; 39.9 deg HFOV)



Point of Perspective

Viewpoint 18 Summer Single Frame 50mm Reference image

Limedown Solar Park

Camera Location:

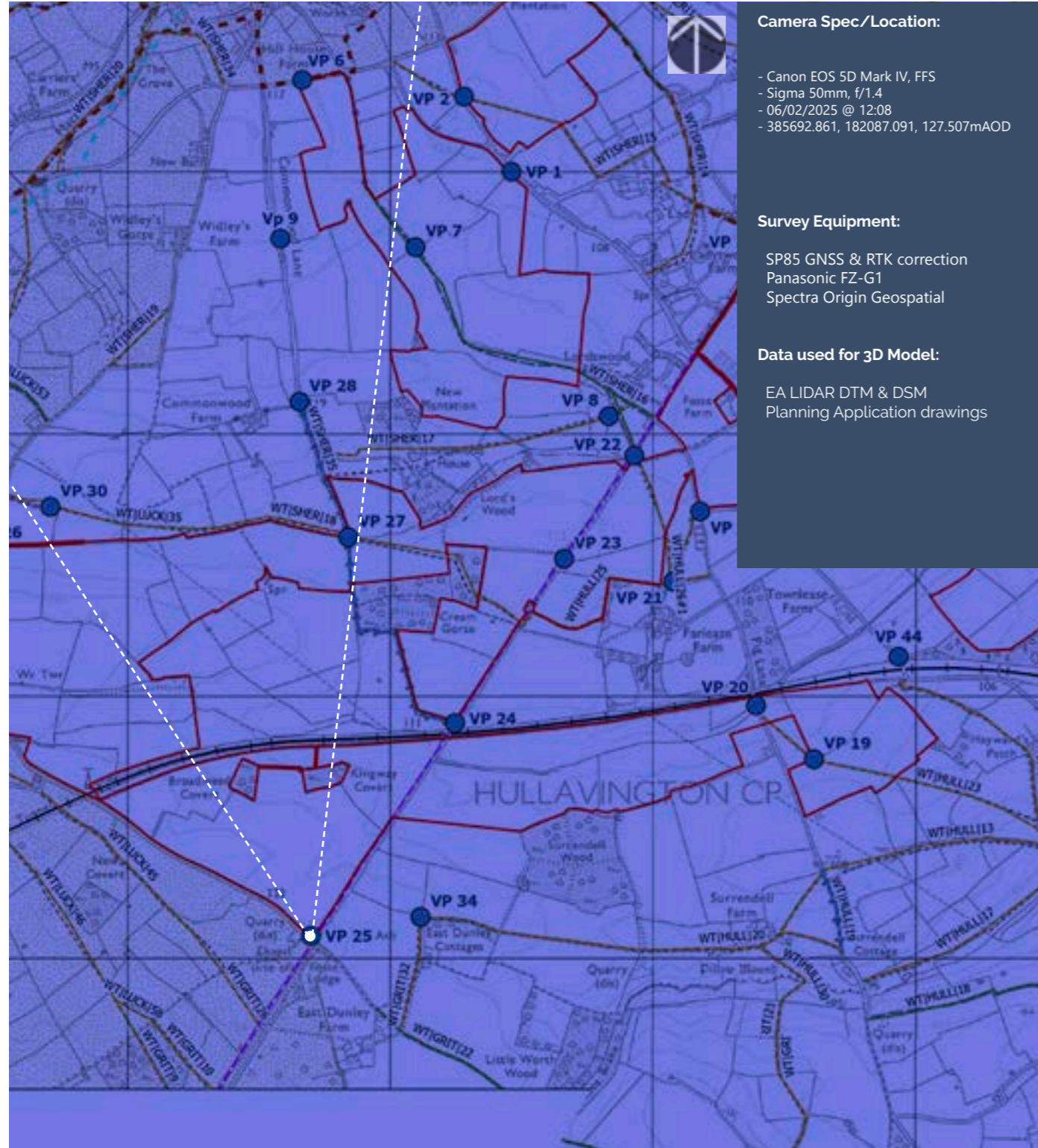

© Crown Copyright and database rights 2025 Ordnance Survey 0100031673

Tripod:



50mm Lens Planar Projection (actual 49.6mm; 39.9 deg HFOV)



Point of Perspective

Point of Perspective

Point of Perspective

Point of Perspective

Viewpoint 25 Winter Single Frame 50mm Reference image

Camera Location:

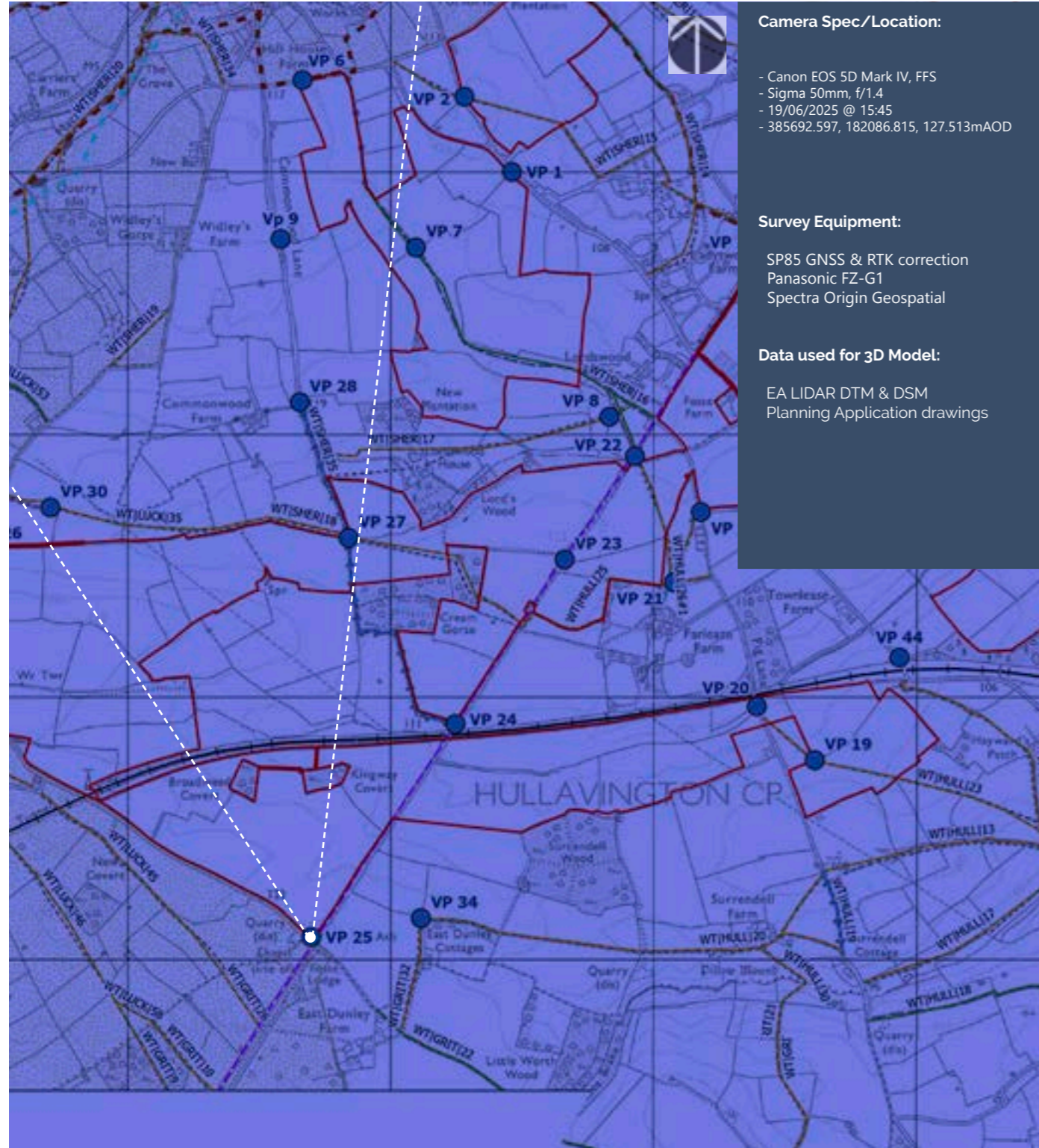

Copyright and database rights 2025 Ordnance Survey 0100031673

Tripod:



50mm Lens Planar Projection (actual 49.6mm; 39.9 deg HFOV)



Point of Perspective

Point of Perspective

Point of Perspective

Point of Perspective

Viewpoint 25 Summer Single Frame 50mm Reference image

Camera Location:

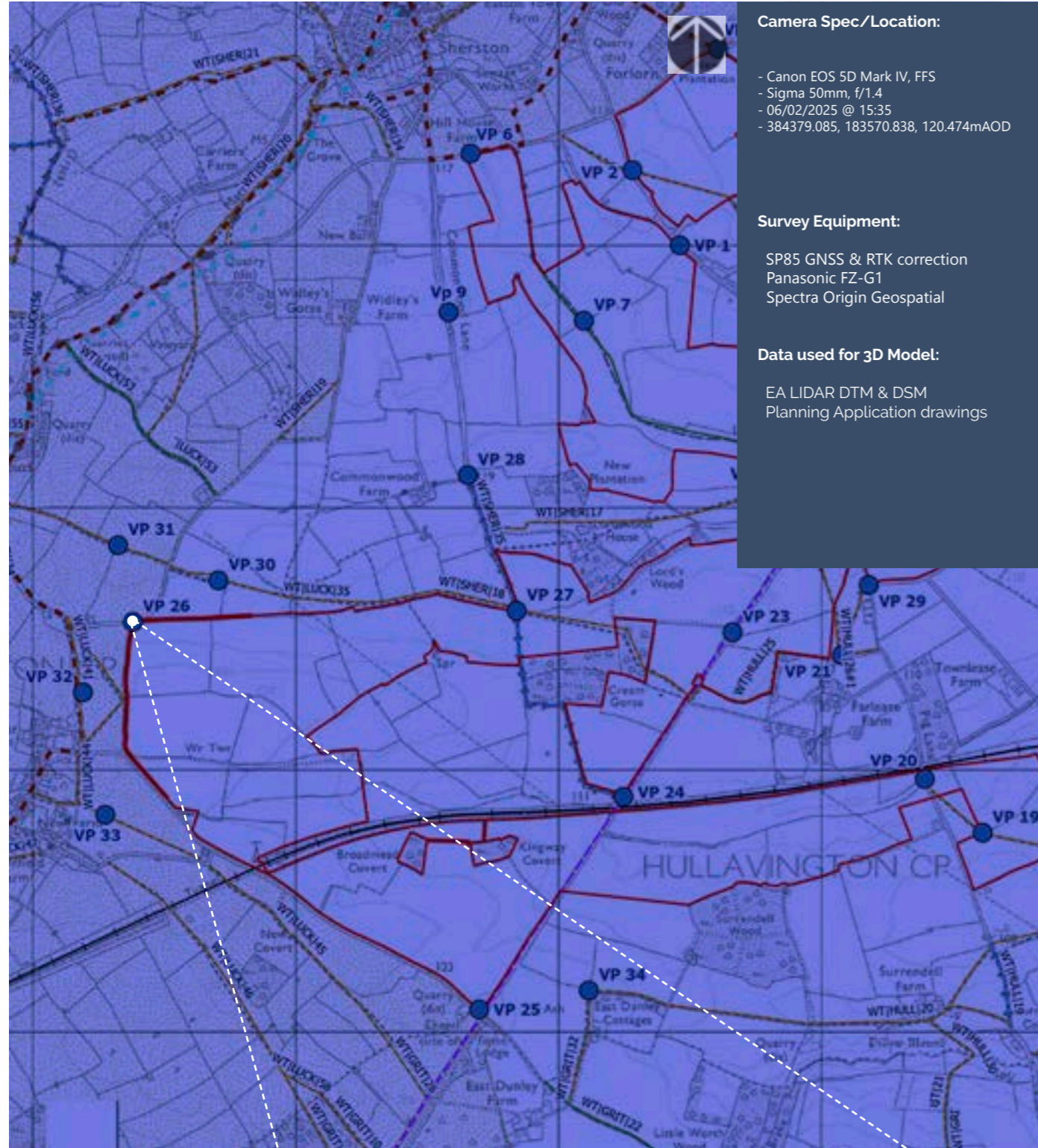

© Crown Copyright and database rights 2025 Ordnance Survey 0100031673

Tripod:



50mm Lens Planar Projection (actual 49.6mm; 39.9 deg HFOV)



Point of Perspective

Point of Perspective

Point of Perspective

Point of Perspective

Viewpoint 26 Winter Single Frame 50mm Reference image

Camera Location:

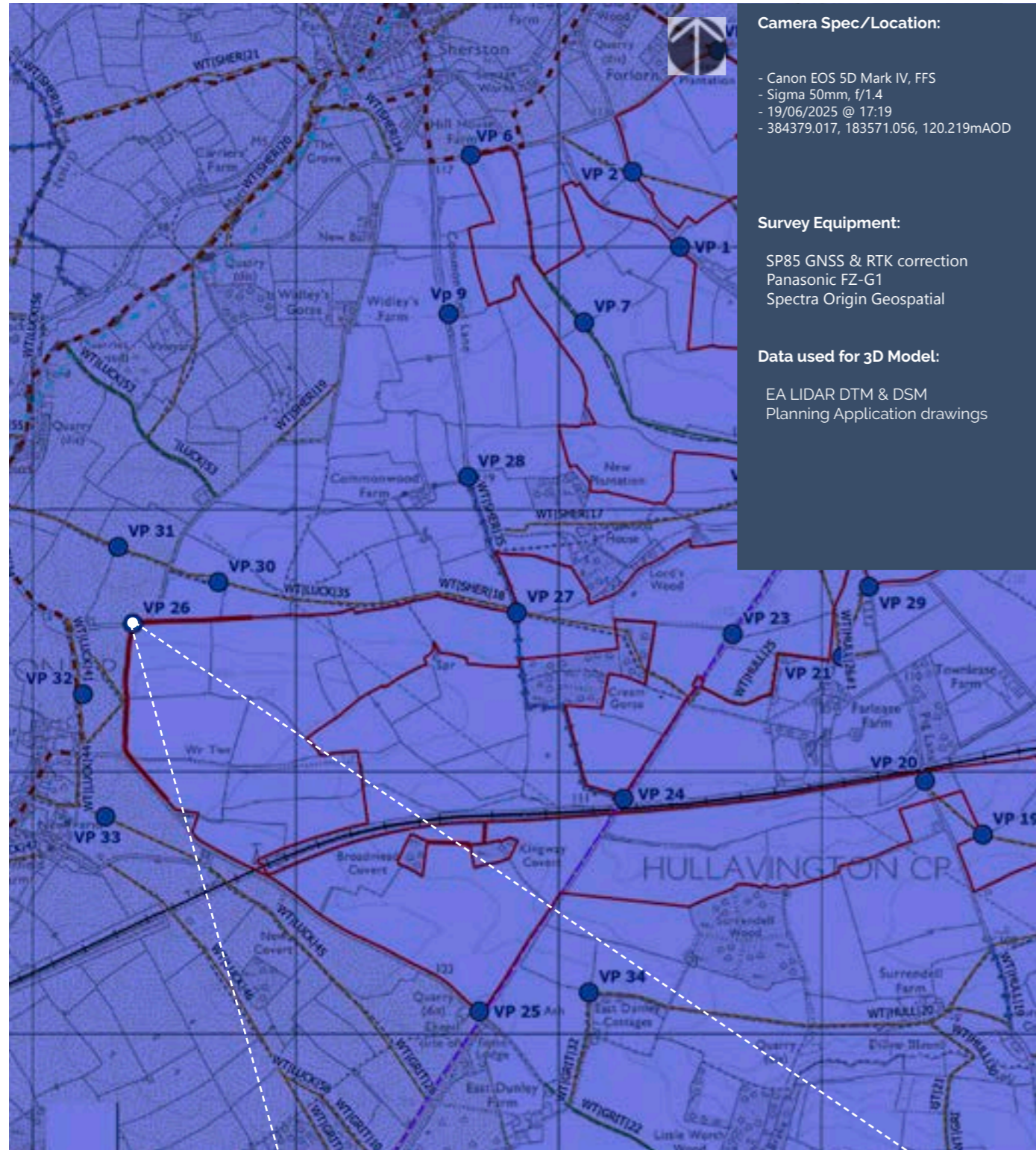

Own Copyright and database rights 2025 Ordnance Survey 0100031673

Tripod:



50mm Lens Planar Projection (actual 49.6mm; 39.9 deg HFOV)



Point of Perspective

Point of Perspective

Point of Perspective

Point of Perspective

Viewpoint 26 Summer Single Frame 50mm Reference image

Camera Location:

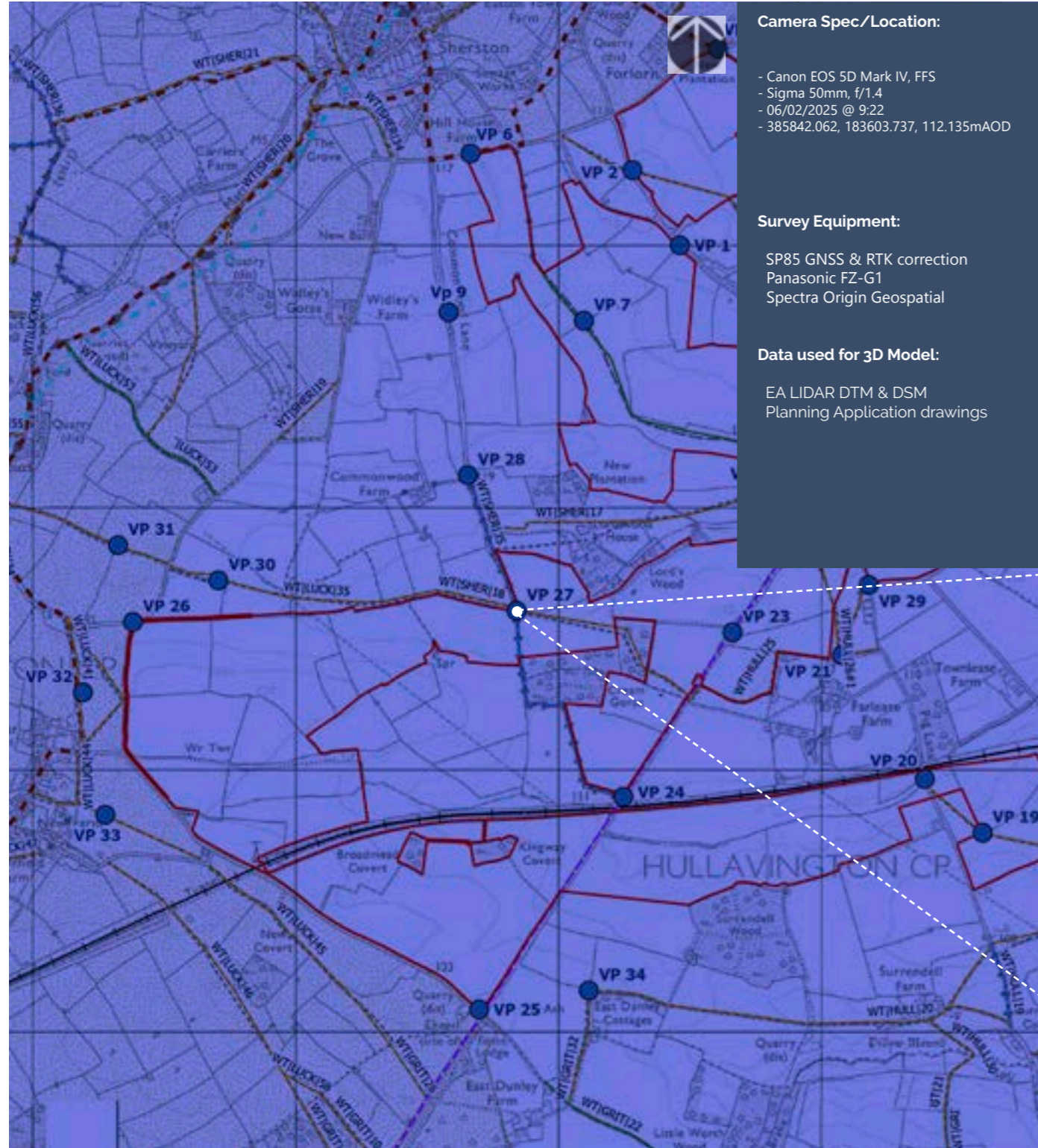

Copyright and database rights 2025 Ordnance Survey 0100031673

Tripod:



50mm Lens Planar Projection (actual 49.6mm; 39.9 deg HFOV)



Point of Perspective

Point of Perspective

Point of Perspective

Point of Perspective

Viewpoint 27 Winter Single Frame 50mm Reference image

Camera Location:

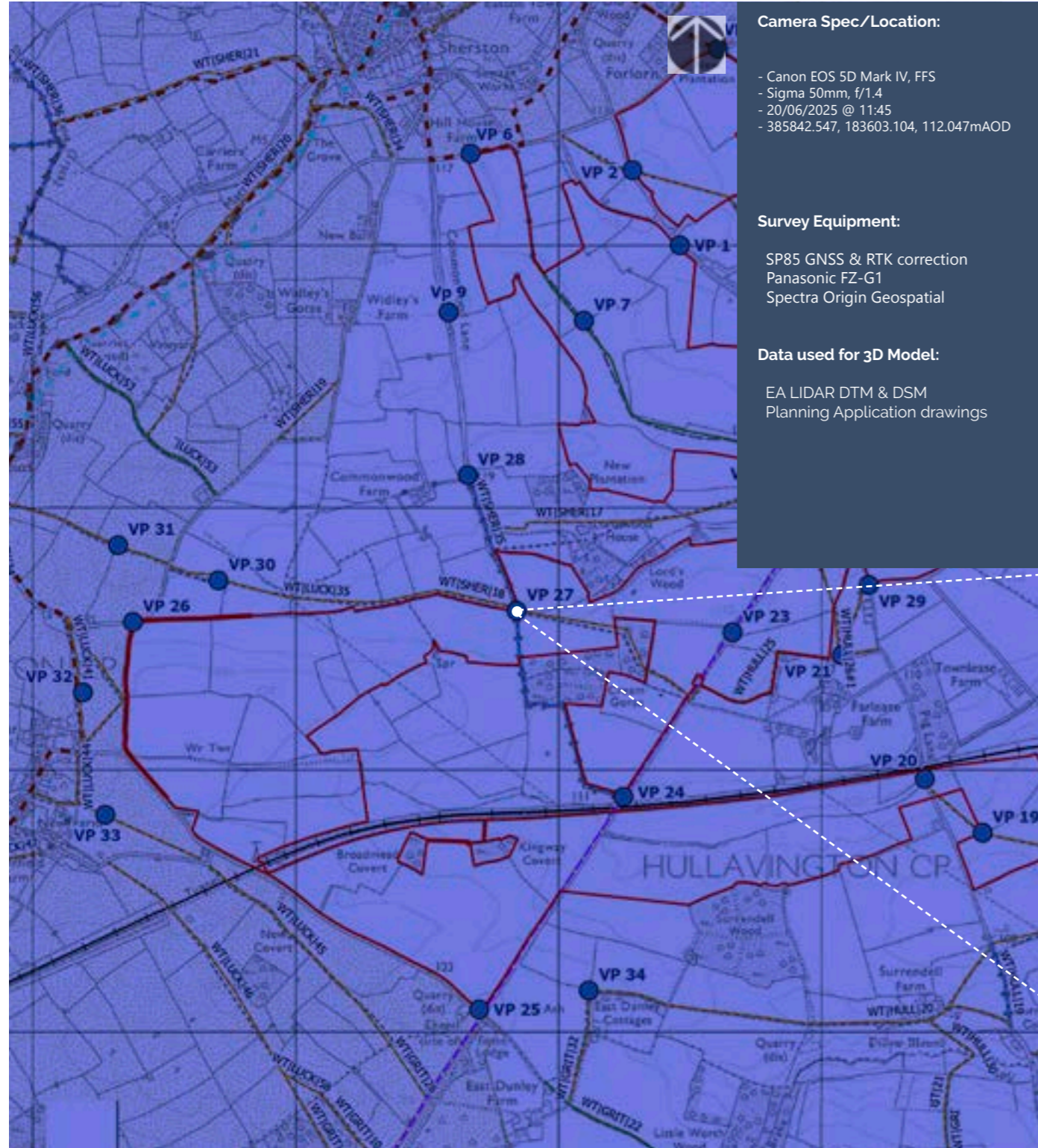

Ordnance Survey 0100031673

Tripod:



50mm Lens Planar Projection (actual 49.6mm; 39.9 deg HFOV)



Point of Perspective

Point of Perspective

Point of Perspective

Point of Perspective

Viewpoint 27 Summer Single Frame 50mm Reference image

Camera Location:

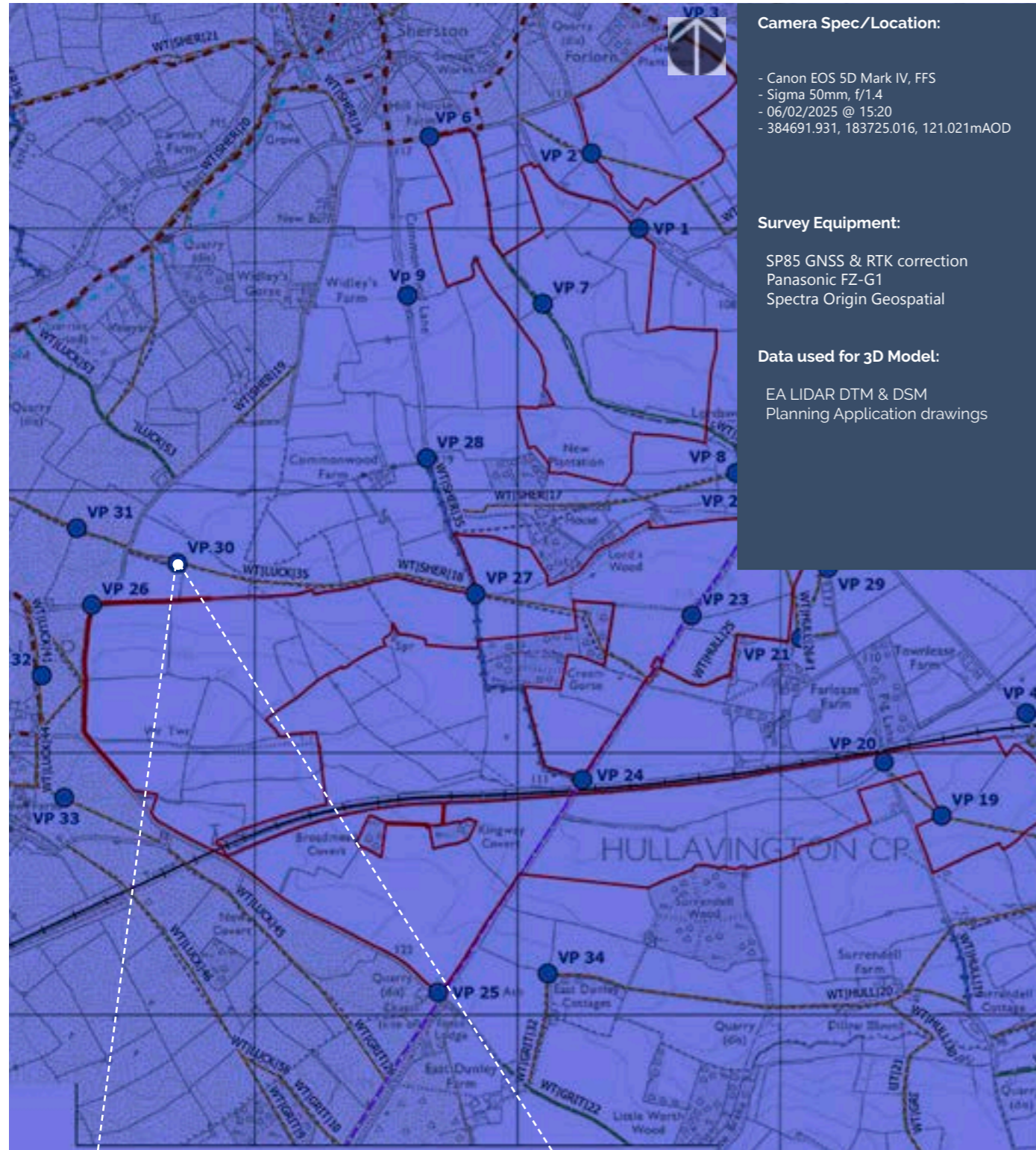

Crown Copyright and database rights 2025 Ordnance Survey 0100031673

Tripod:



50mm Lens Planar Projection (actual 49.6mm; 39.9 deg HFOV)



Point of Perspective

Point of Perspective

Point of Perspective

Point of Perspective

Viewpoint 30 Winter Single Frame 50mm Reference image

Camera Location:

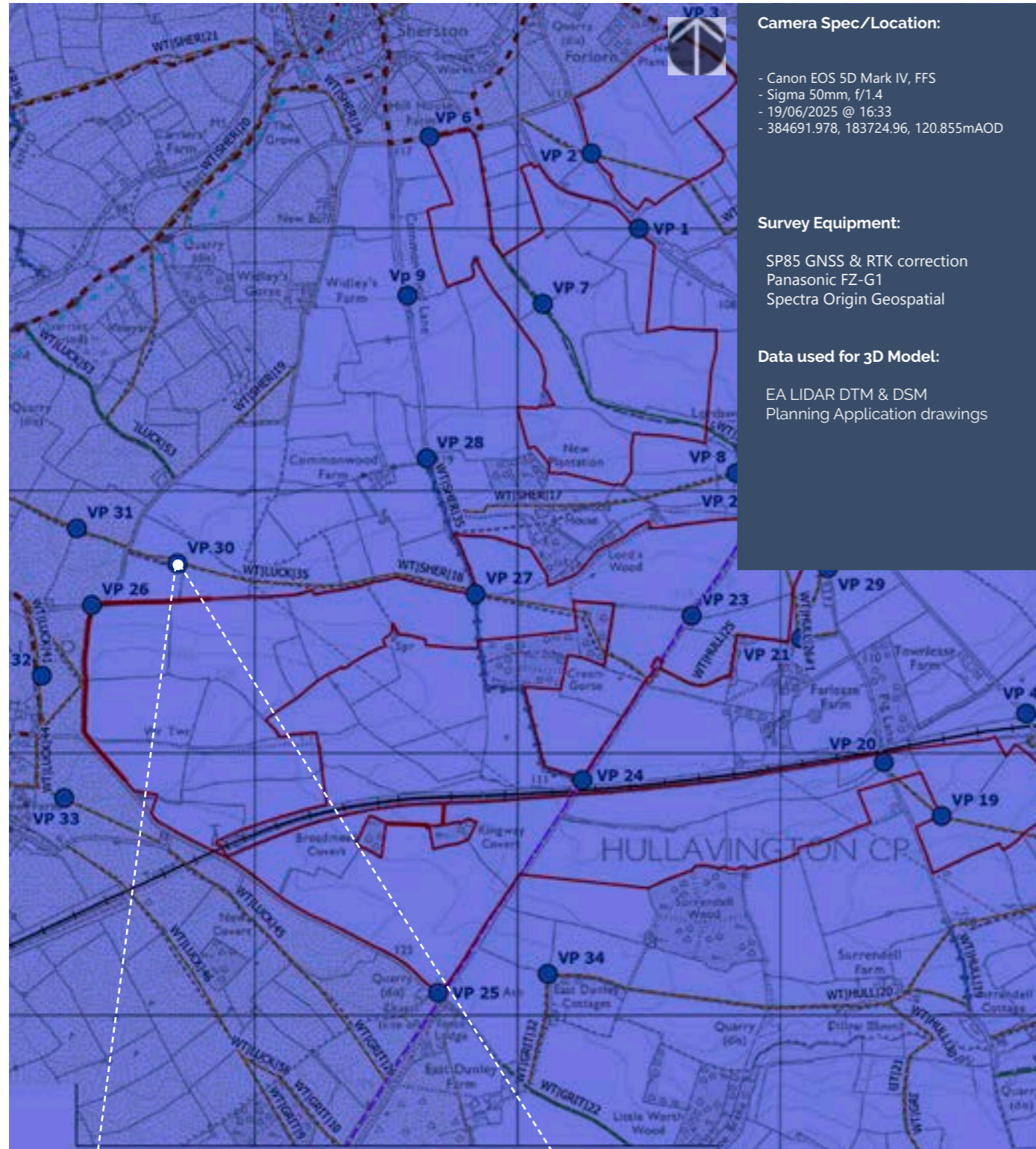

Crown Copyright and database rights 2025 Ordnance Survey 0100031673

Tripod:



50mm Lens Planar Projection (actual 49.6mm; 39.9 deg HFOV)



Point of Perspective

Point of Perspective

Point of Perspective

Point of Perspective

Viewpoint 30 Summer Single Frame 50mm Reference image

Limedown Solar Park

Camera Location:

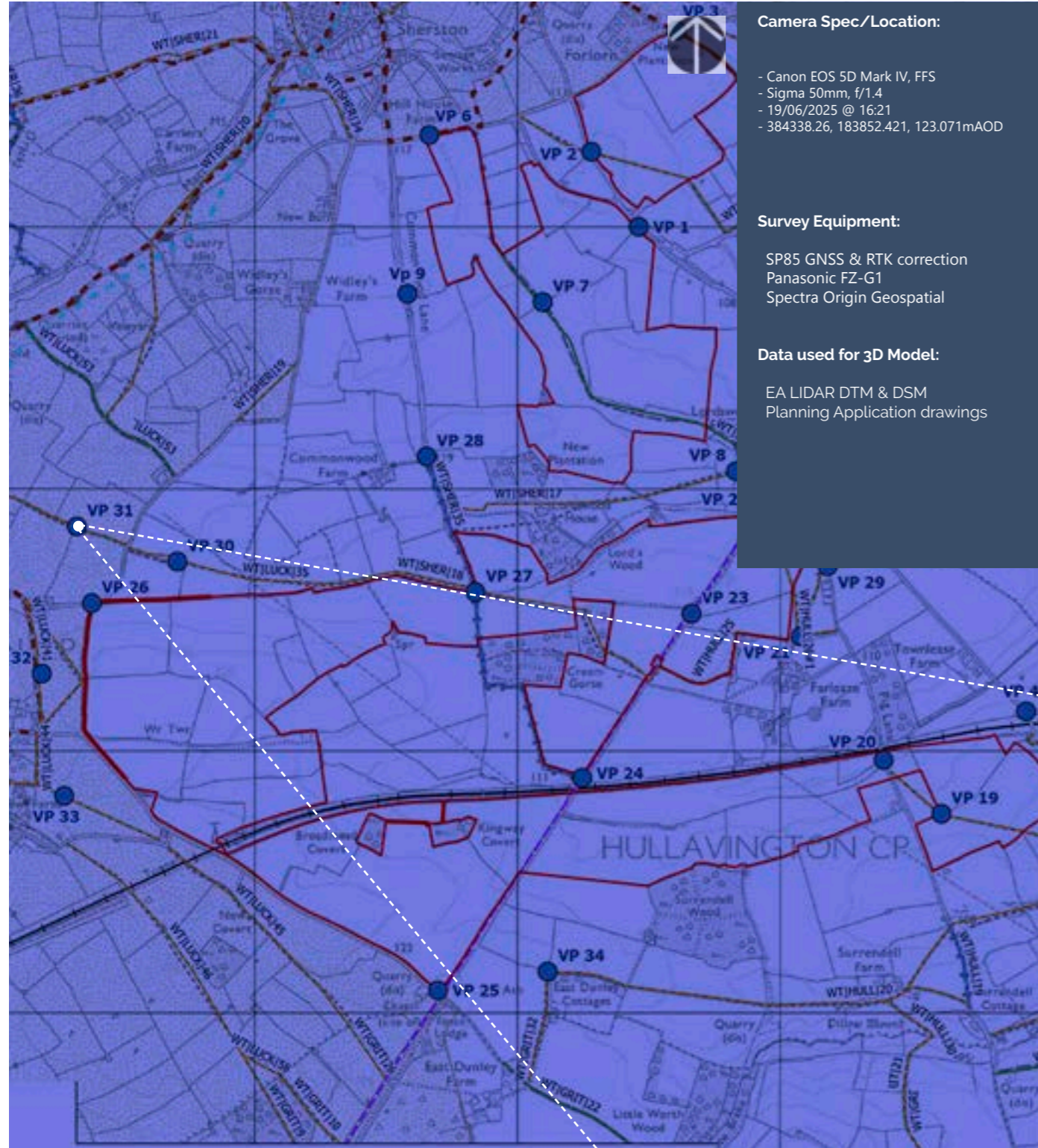

© Crown Copyright and database rights 2025 Ordnance Survey 0100031673

Tripod:



50mm Lens Planar Projection (actual 49.6mm; 39.9 deg HFOV)



Point of Perspective

Viewpoint 31 Winter Single Frame 50mm Reference image

Limedown Solar Park

Camera Location:

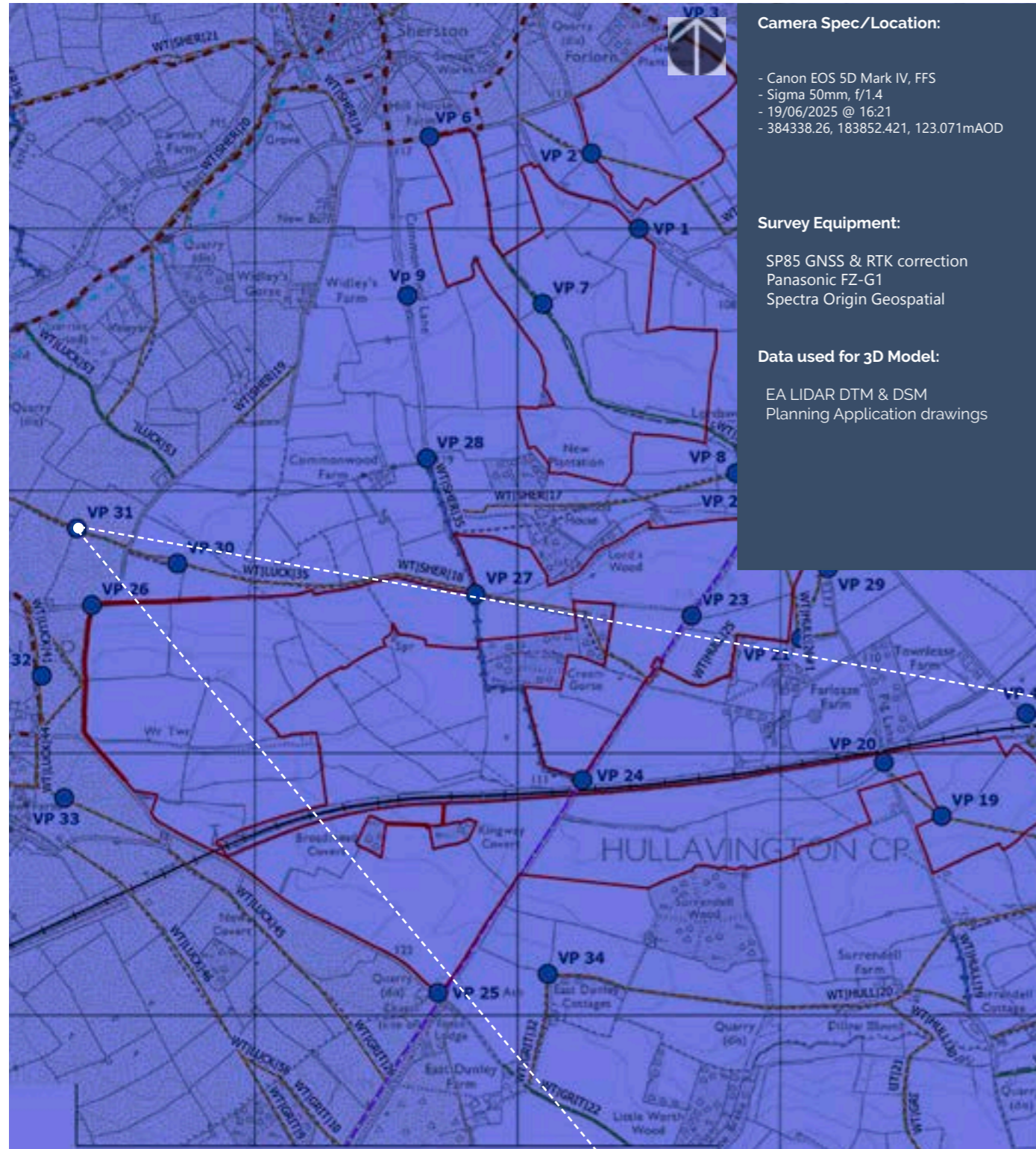

Crown Copyright and database rights 2025 Ordnance Survey 0100031673

Tripod:



50mm Lens Planar Projection (actual 49.6mm; 39.9 deg HFOV)



Point of Perspective

Point of Perspective

Point of Perspective

Point of Perspective

Viewpoint 31 Summer Single Frame 50mm Reference image

Camera Location:

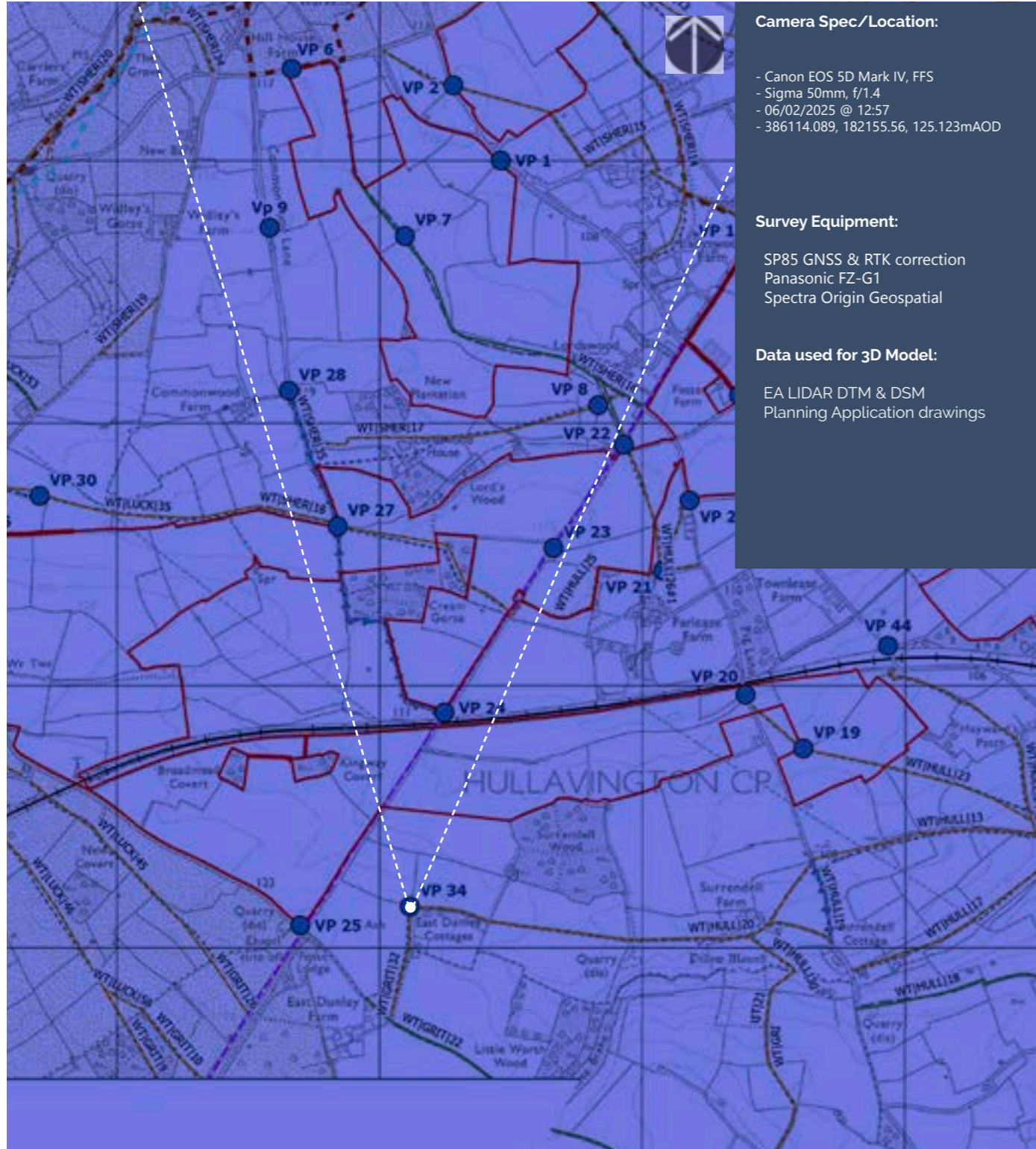

Copyright and database rights 2025 Ordnance Survey 0100031673

Tripod:



50mm Lens Planar Projection (actual 49.6mm; 39.9 deg HFOV)

Point of Perspective



Point of Perspective

Point of Perspective

Point of Perspective

Viewpoint 34 Winter Single Frame 50mm Reference image

Limedown Solar Park

Camera Location:

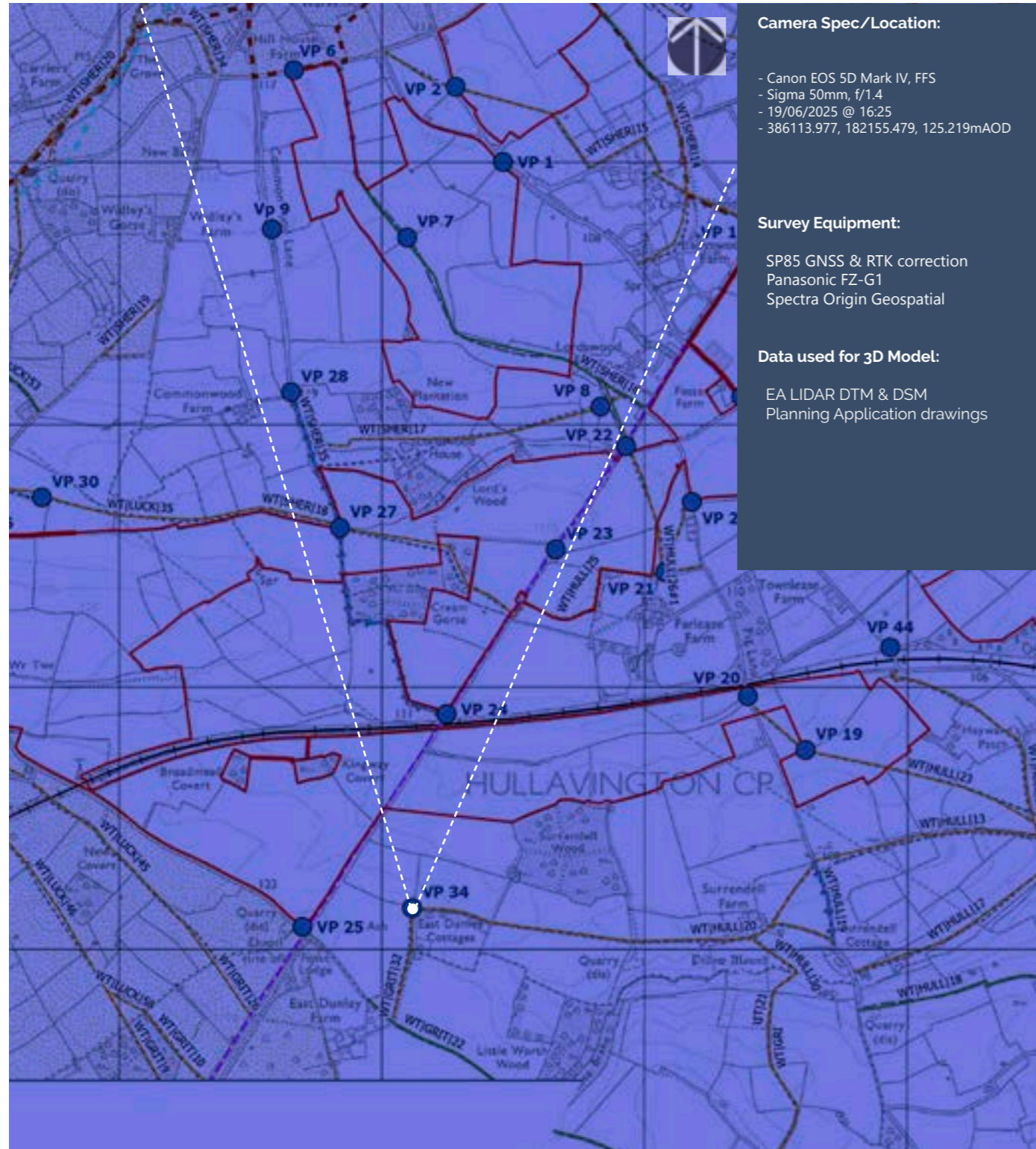

Copyright and database rights 2025 Ordnance Survey 0100031673

Tripod:



50mm Lens Planar Projection (actual 49.6mm; 39.9 deg HFOV)



Point of Perspective

Point of Perspective

Point of Perspective

Point of Perspective

Viewpoint 34 Summer Single Frame 50mm Reference image

Camera Location:

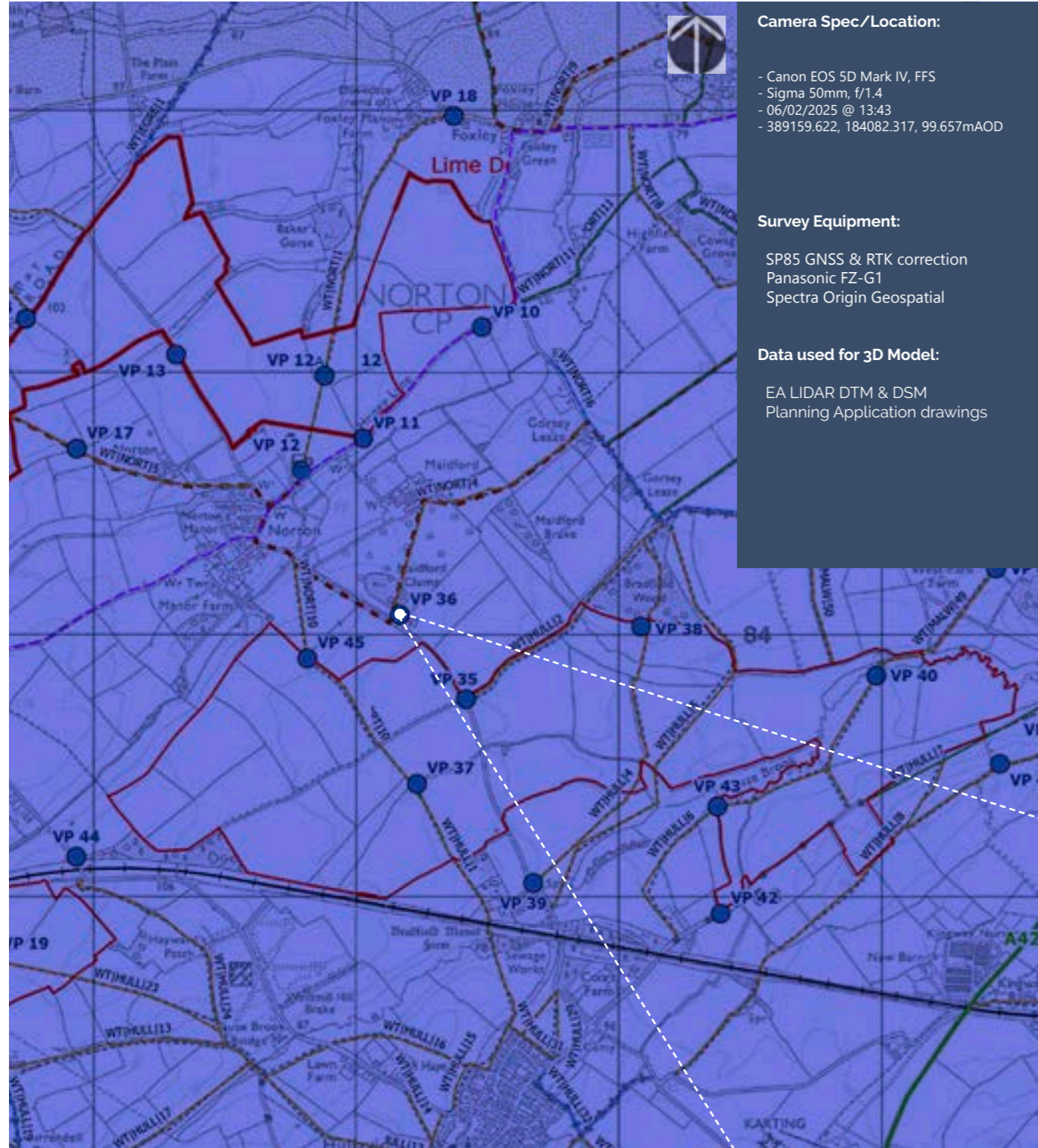

Ordnance Survey 2025 Copyright and database rights 0100031673

Tripod:



50mm Lens Planar Projection (actual 49.6mm; 39.9 deg HFOV)



Point of Perspective

Point of Perspective

Point of Perspective

Point of Perspective

Viewpoint 36 Winter Single Frame 50mm Reference image

Camera Location:

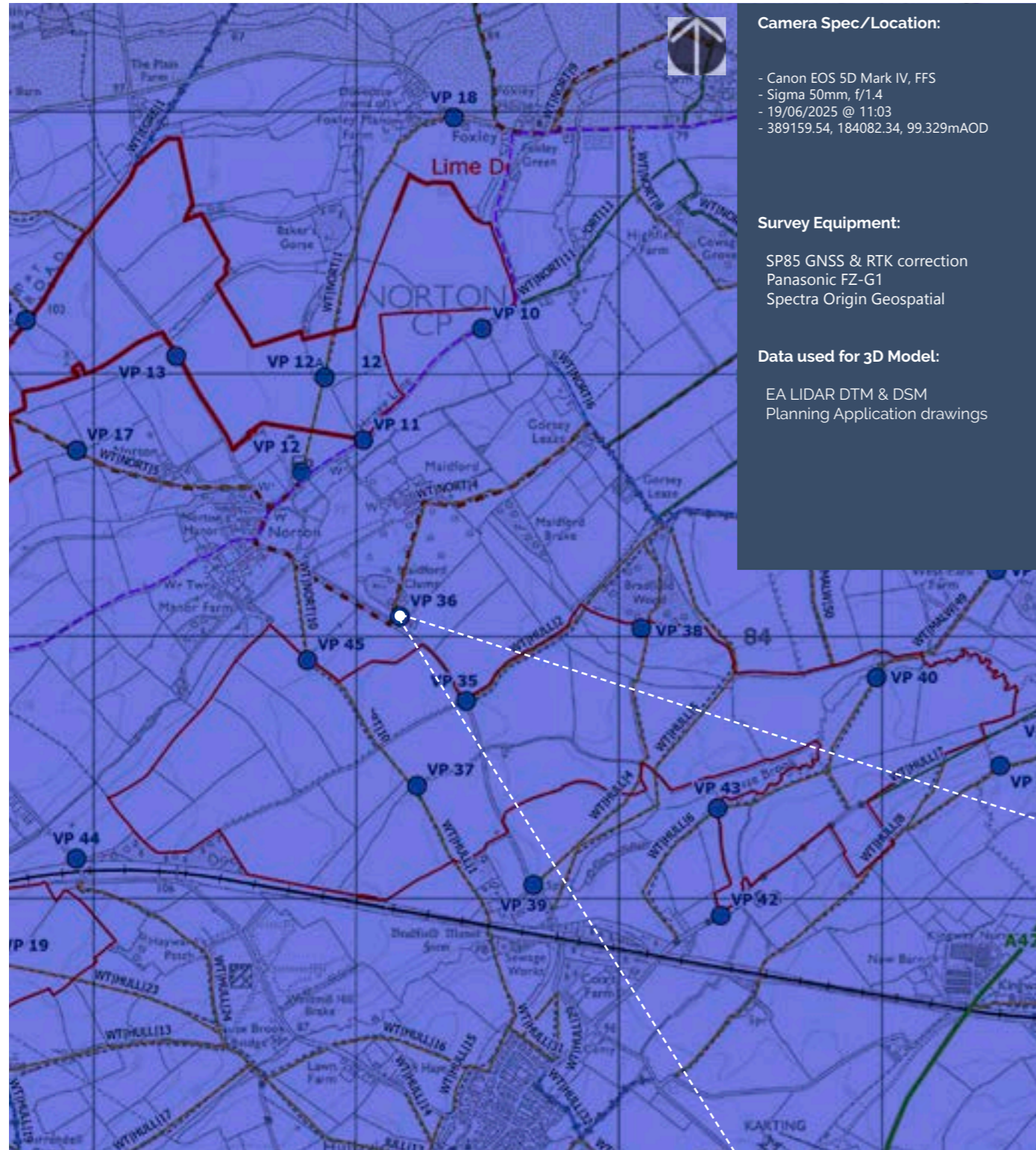

Own Copyright and database rights 2025 Ordnance Survey 0100031673

Tripod:



50mm Lens Planar Projection (actual 49.6mm; 39.9 deg HFOV)

Point of Perspective



Point of Perspective

Point of Perspective

Point of Perspective

Viewpoint 36 Summer Single Frame 50mm Reference image

Camera Location:

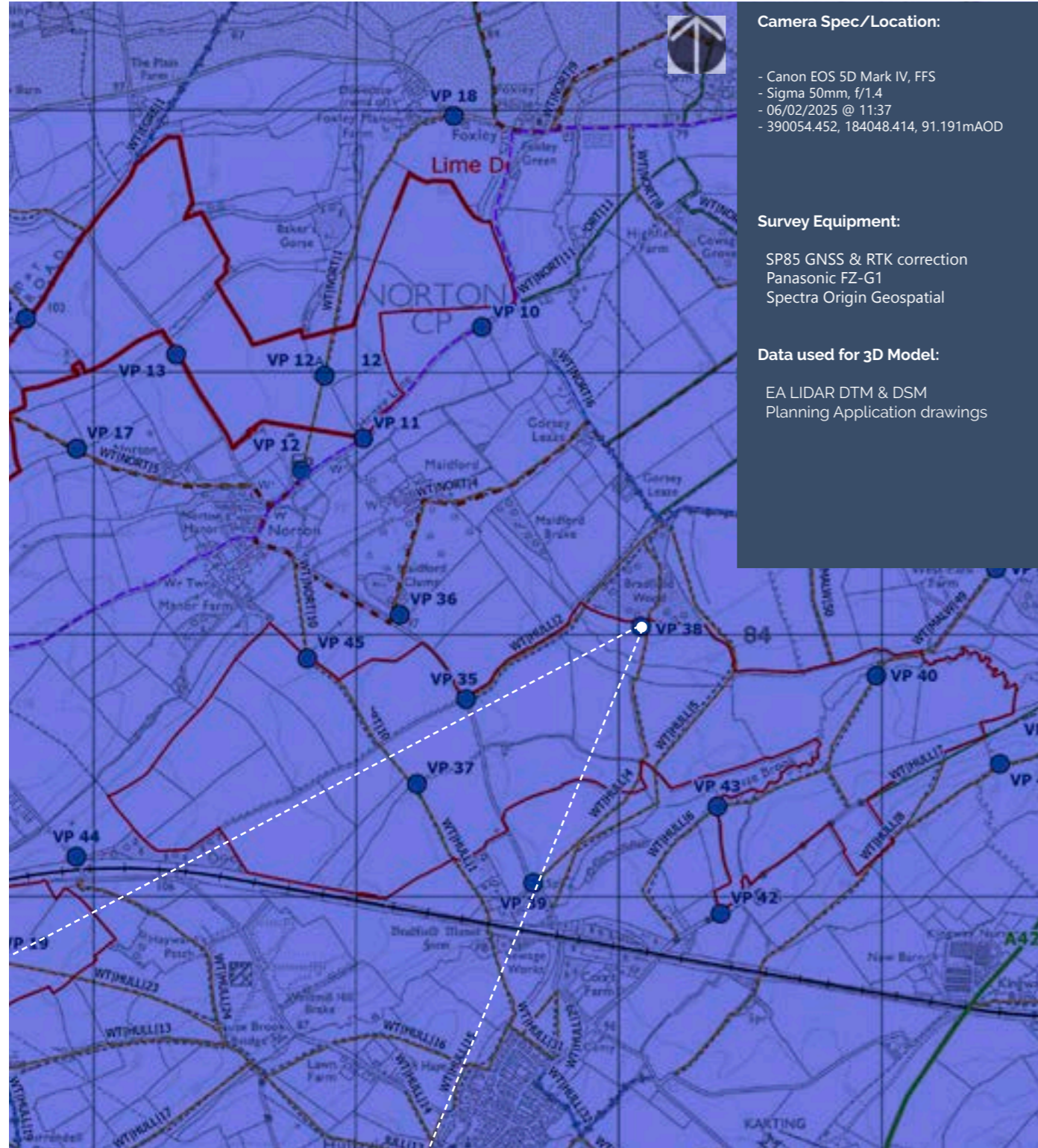

Ordnance Survey Copyright and database rights 2025 Ordnance Survey 0100031673

Tripod:



50mm Lens Planar Projection (actual 49.6mm; 39.9 deg HFOV)



Point of Perspective

Point of Perspective

Point of Perspective

Point of Perspective

Viewpoint 38 Winter Single Frame 50mm Reference image

Camera Location:

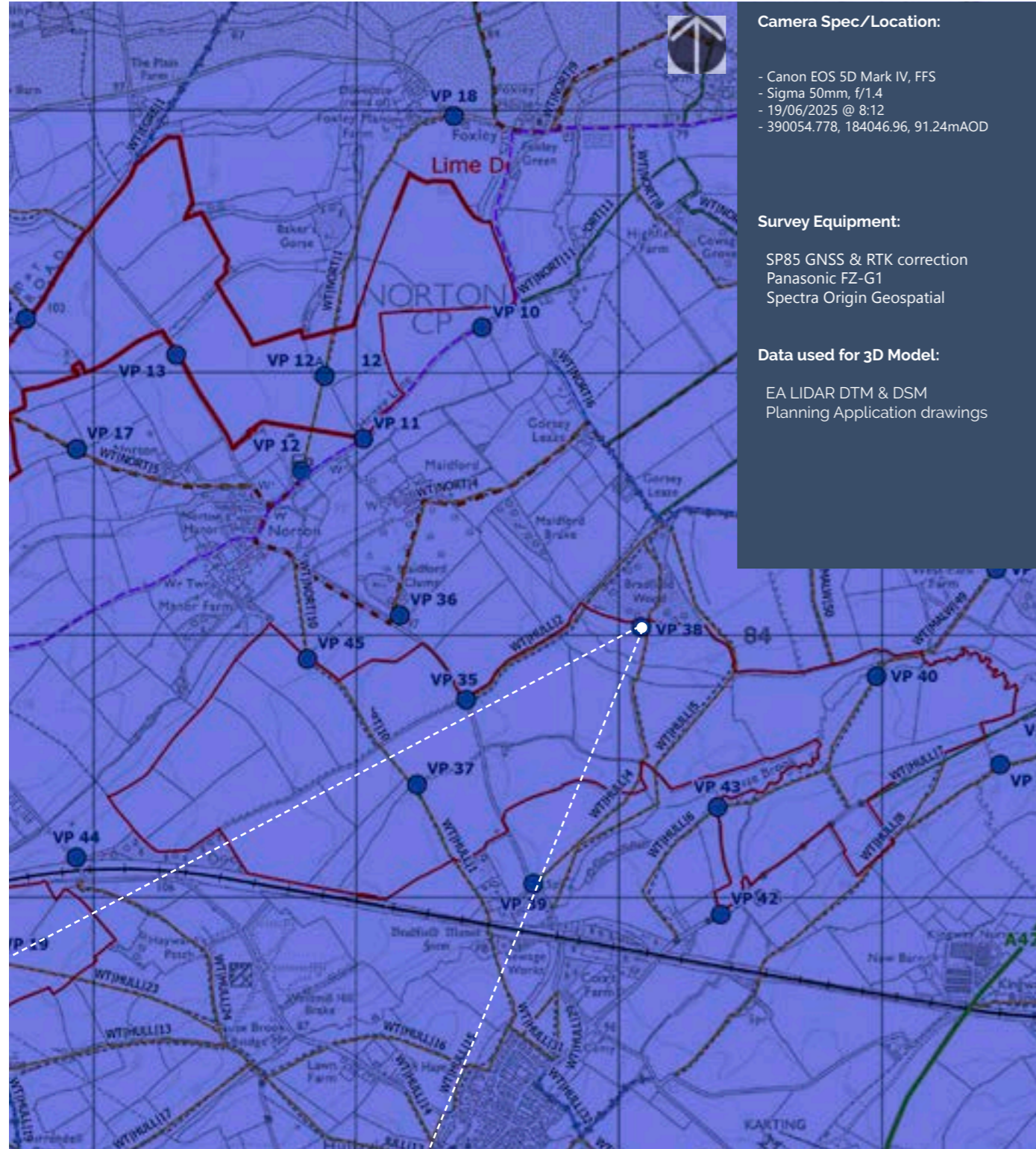

Camera Spec/Location:

- Canon EOS 5D Mark IV, FFS
- Sigma 50mm, f/1.4
- 19/06/2025 @ 8:12
- 390054.778, 184046.96, 91.24mAOD

Survey Equipment:

- SP85 GNSS & RTK correction
- Panasonic FZ-G1
- Spectra Origin Geospatial

Data used for 3D Model:

- EA LIDAR DTM & DSM
- Planning Application drawings

Tripod:



50mm Lens Planar Projection (actual 49.6mm; 39.9 deg HFOV)



Point of Perspective

Point of Perspective

Point of Perspective

Point of Perspective

Viewpoint 38 Summer Single Frame 50mm Reference image

Camera Location:

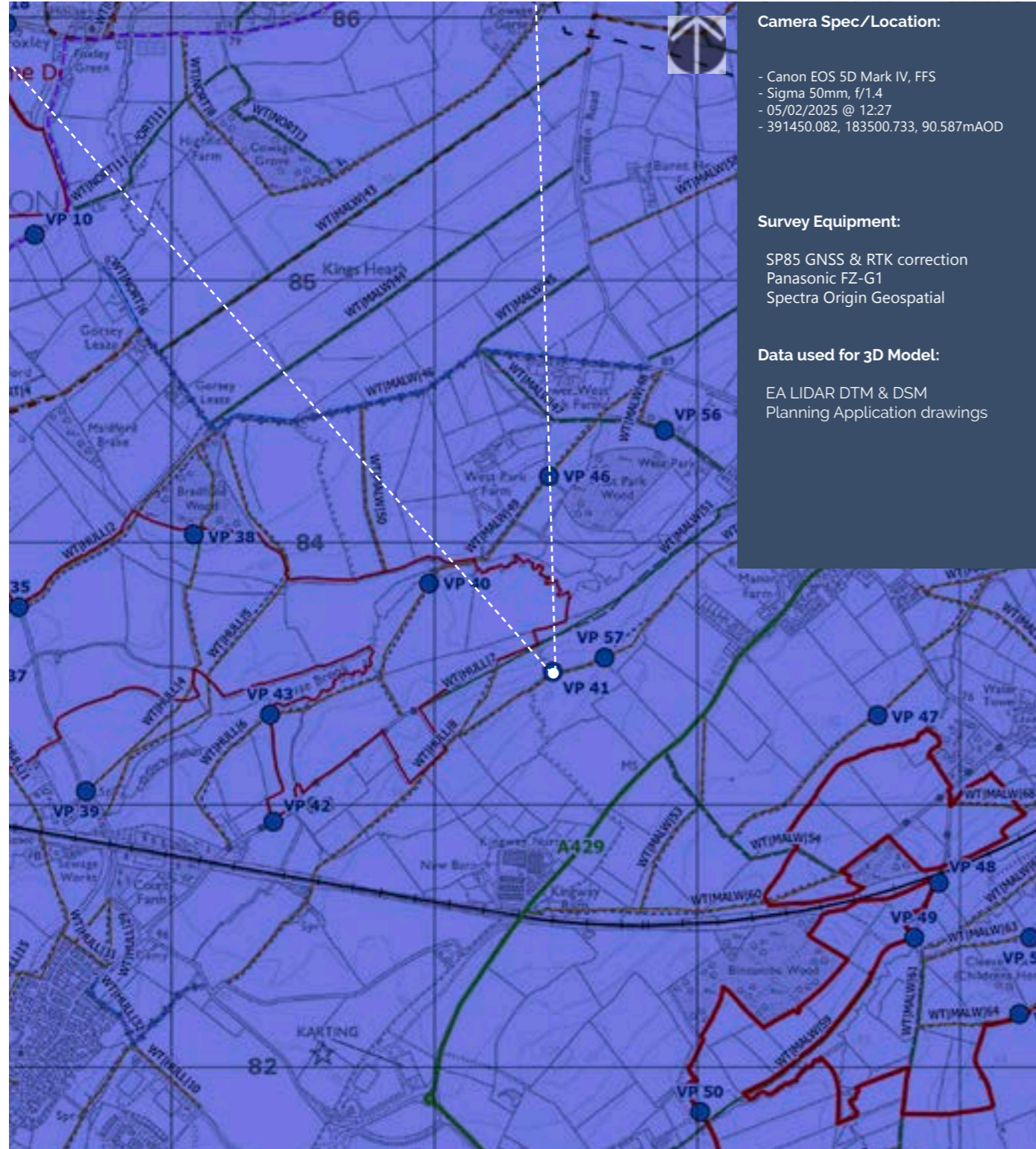

Tripod:



50mm Lens Planar Projection (actual 49.6mm; 39.9 deg HFOV)



Point of Perspective

Point of Perspective

Point of Perspective

Point of Perspective

Viewpoint 41 Winter Single Frame 50mm Reference image

Camera Location:

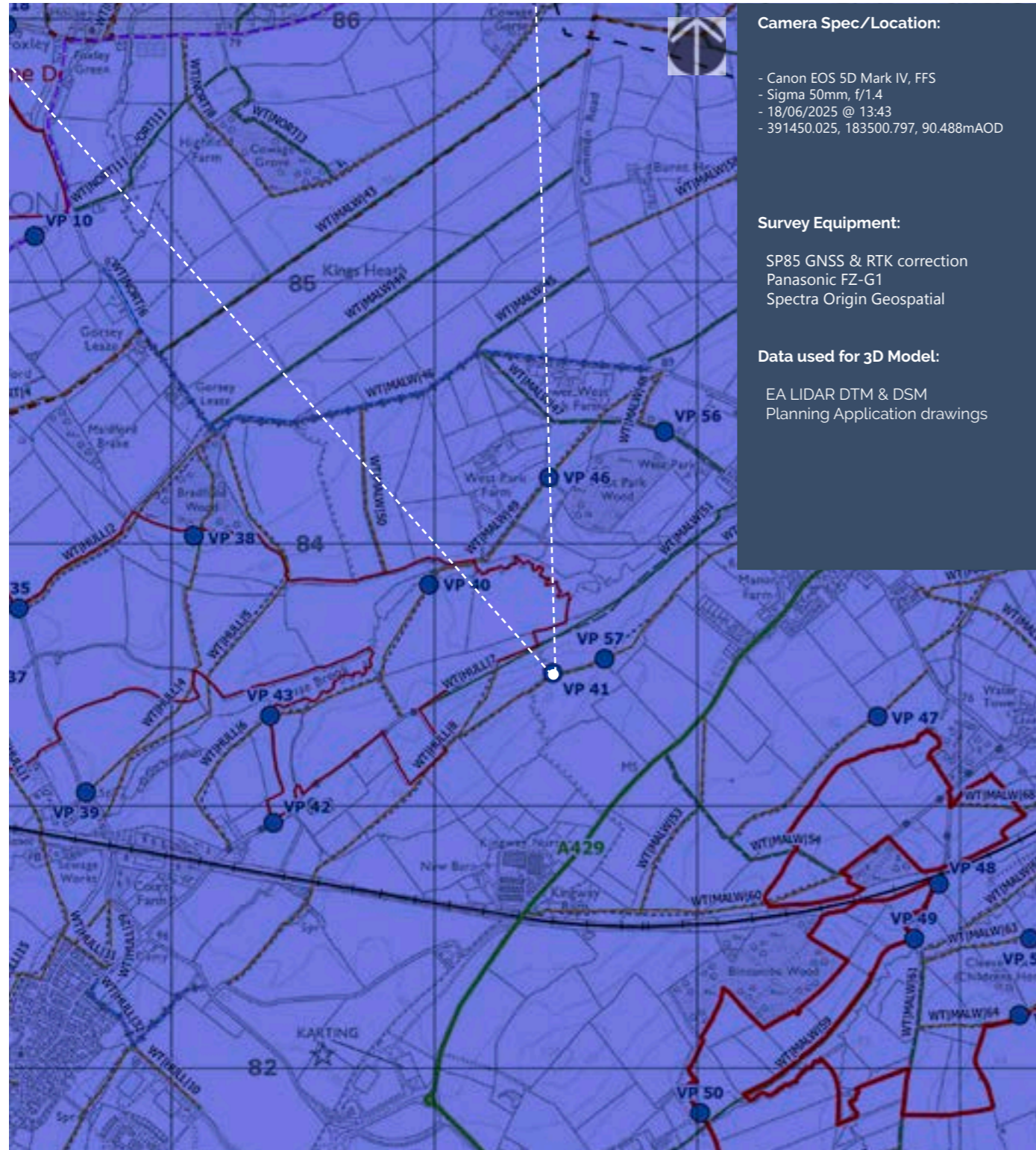

© Crown Copyright and database rights 2025 Ordnance Survey 0100031673

Tripod:



50mm Lens Planar Projection (actual 49.6mm; 39.9 deg HFOV)



Point of Perspective

Viewpoint 41 Summer Single Frame 50mm Reference image

Limedown Solar Park

Camera Location:

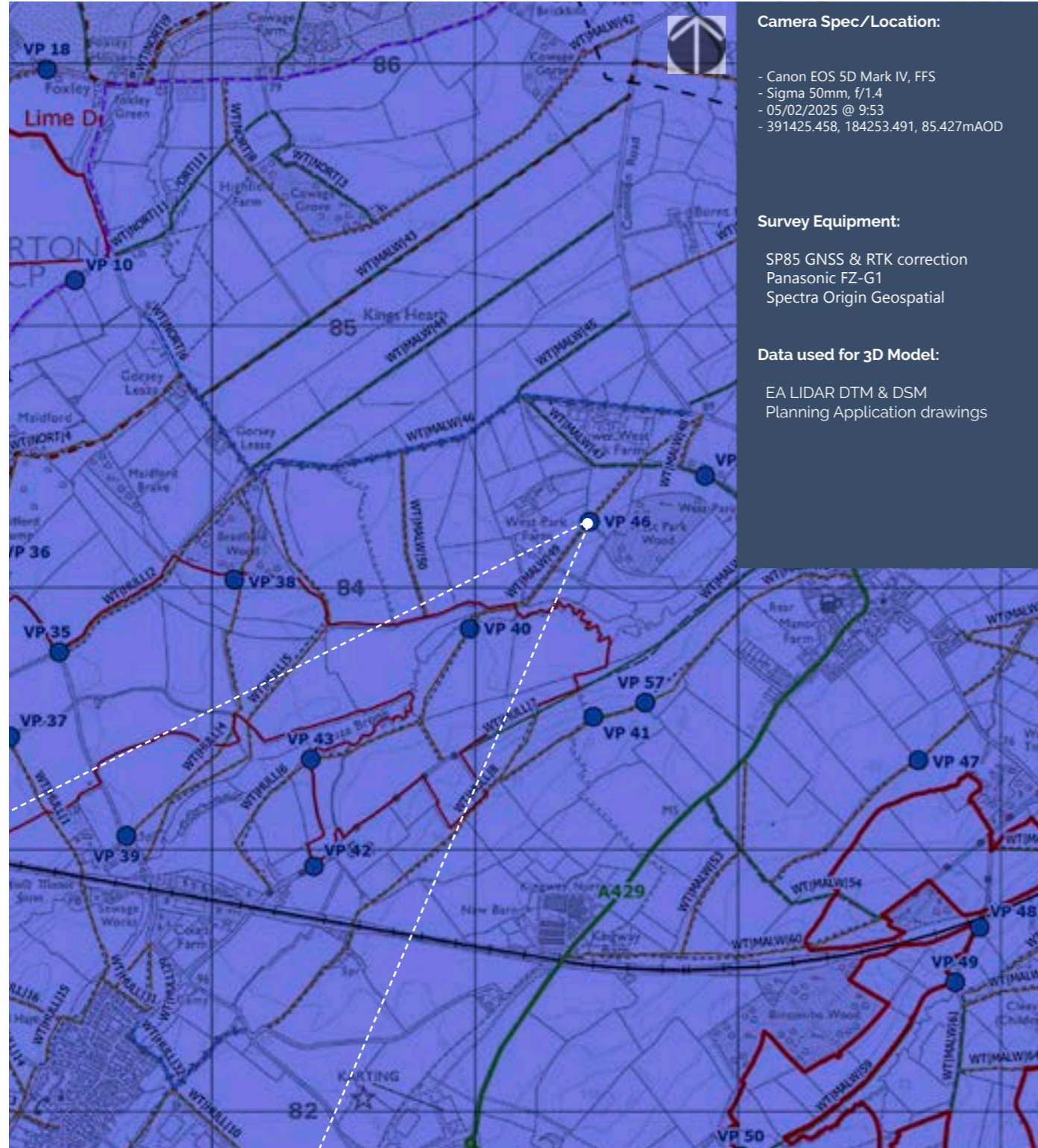

Crown Copyright and database rights 2025 Ordnance Survey 0100031673

Tripod:



50mm Lens Planar Projection (actual 49.6mm; 39.9 deg HFOV)



Point of Perspective

Point of Perspective

Point of Perspective

Point of Perspective

Viewpoint 46 Winter Single Frame 50mm Reference image

Camera Location:

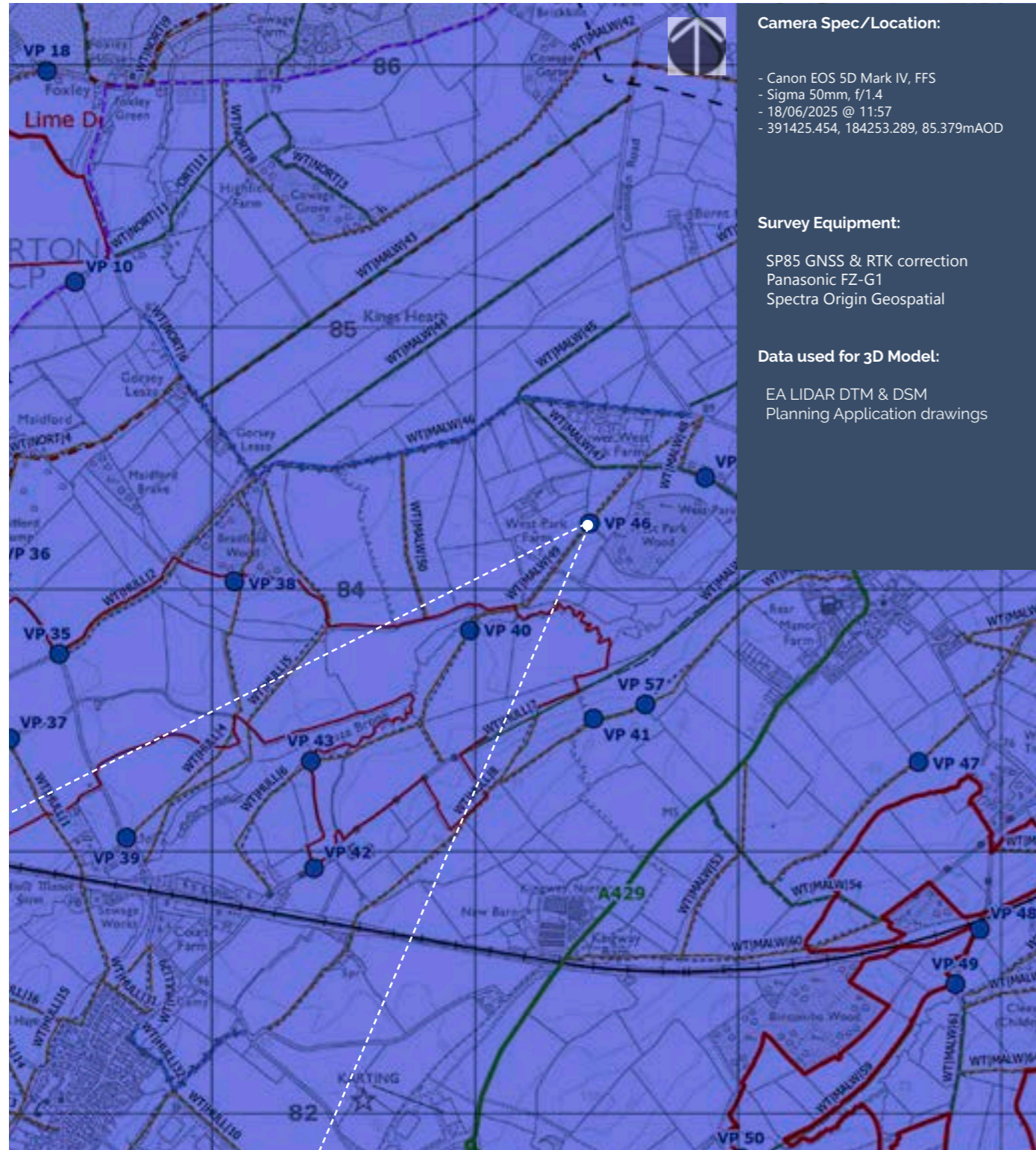

Crown Copyright and database rights 2025 Ordnance Survey 0100031673

Tripod:



50mm Lens Planar Projection (actual 49.6mm; 39.9 deg HFOV)



Point of Perspective

Point of Perspective

Point of Perspective

Point of Perspective

Viewpoint 46 Summer Single Frame 50mm Reference image

Camera Location:

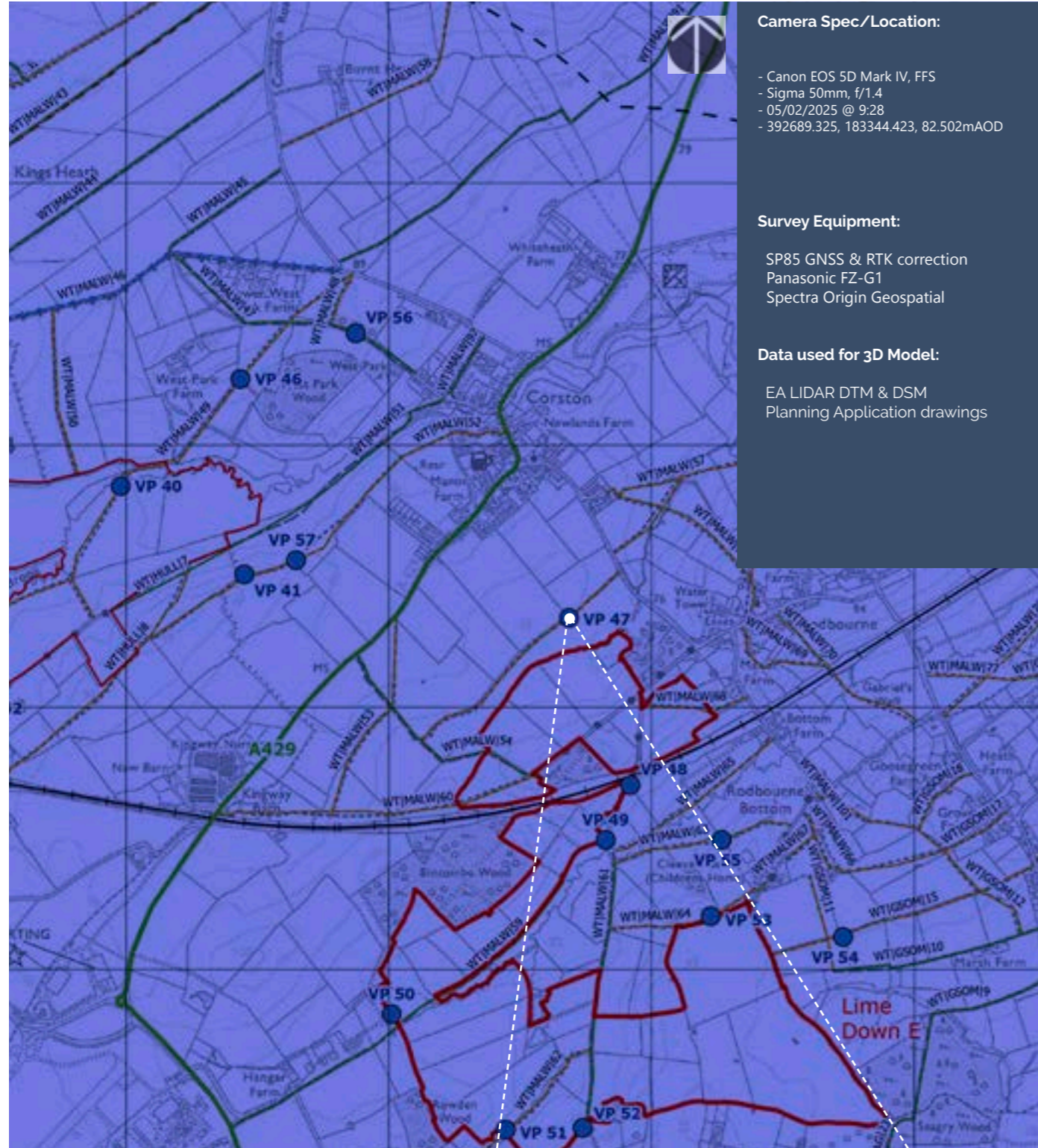

Camera Spec/Location:

- Canon EOS 5D Mark IV, FFS
- Sigma 50mm, f/1.4
- 05/02/2025 @ 9:28
- 392689.325, 183344.423, 82.502mAOD

Survey Equipment:

- SP85 GNSS & RTK correction
- Panasonic FZ-G1
- Spectra Origin Geospatial

Data used for 3D Model:

- EA LIDAR DTM & DSM
- Planning Application drawings

Ordnance Survey Crown Copyright and database rights 2025 0100031673

Tripod:



50mm Lens Planar Projection (actual 49.6mm; 39.9 deg HFOV)

Point of Perspective



Point of Perspective

Point of Perspective

Point of Perspective

Viewpoint 47A Winter Single Frame 50mm Reference image

Camera Location:

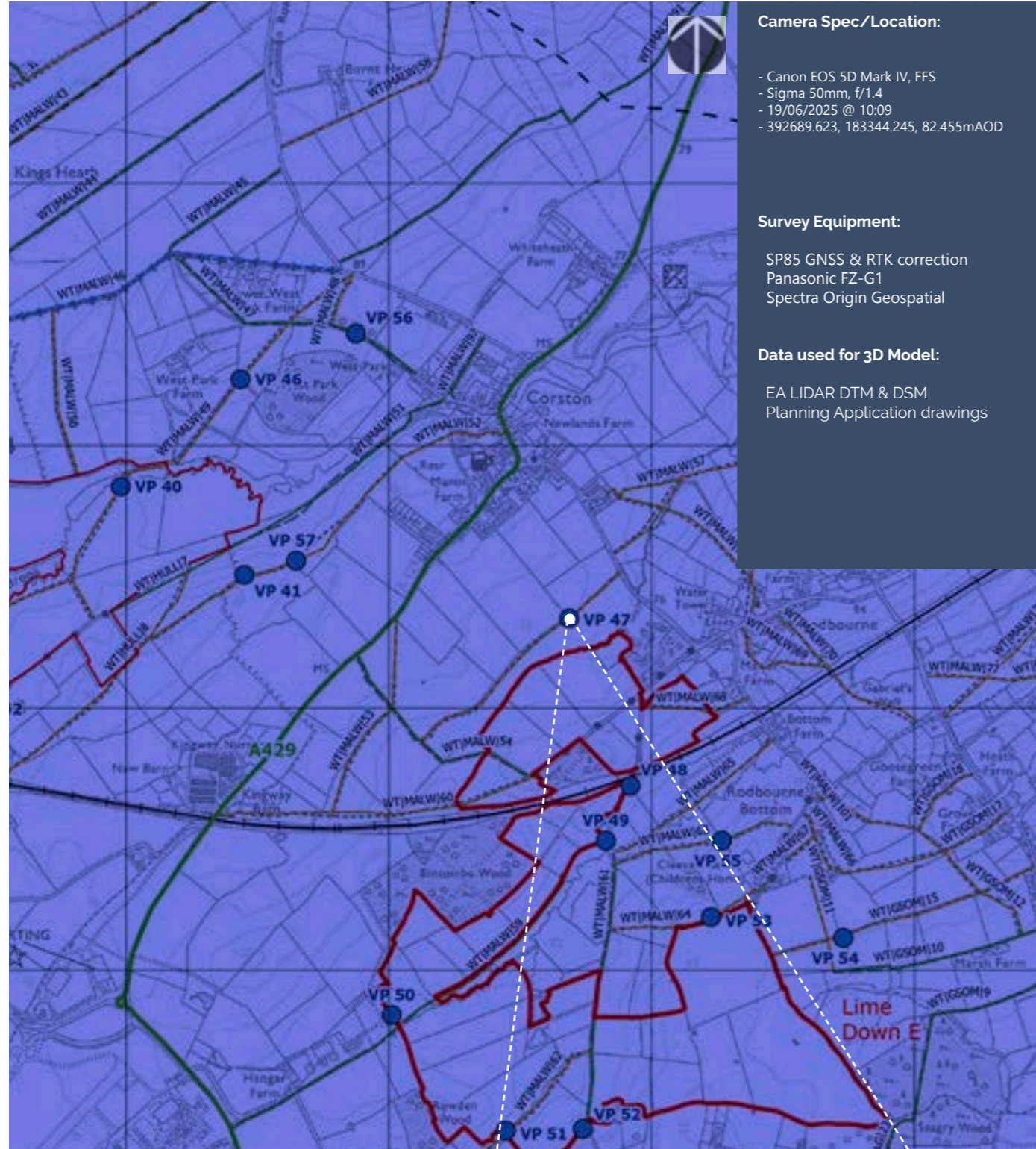

Camera Spec/Location:

- Canon EOS 5D Mark IV, FFS
- Sigma 50mm, f/1.4
- 19/06/2025 @ 10:09
- 392689.623, 183344.245, 82.455mAOD

Survey Equipment:

- SP85 GNSS & RTK correction
- Panasonic FZ-G1
- Spectra Origin Geospatial

Data used for 3D Model:

- EA LIDAR DTM & DSM
- Planning Application drawings

© Crown Copyright and database rights 2025 Ordnance Survey 0100031673

Tripod:



50mm Lens Planar Projection (actual 49.6mm; 39.9 deg HFOV)



Point of Perspective

Point of Perspective

Point of Perspective

Point of Perspective

Viewpoint 47A Summer Single Frame 50mm Reference image

Camera Location:

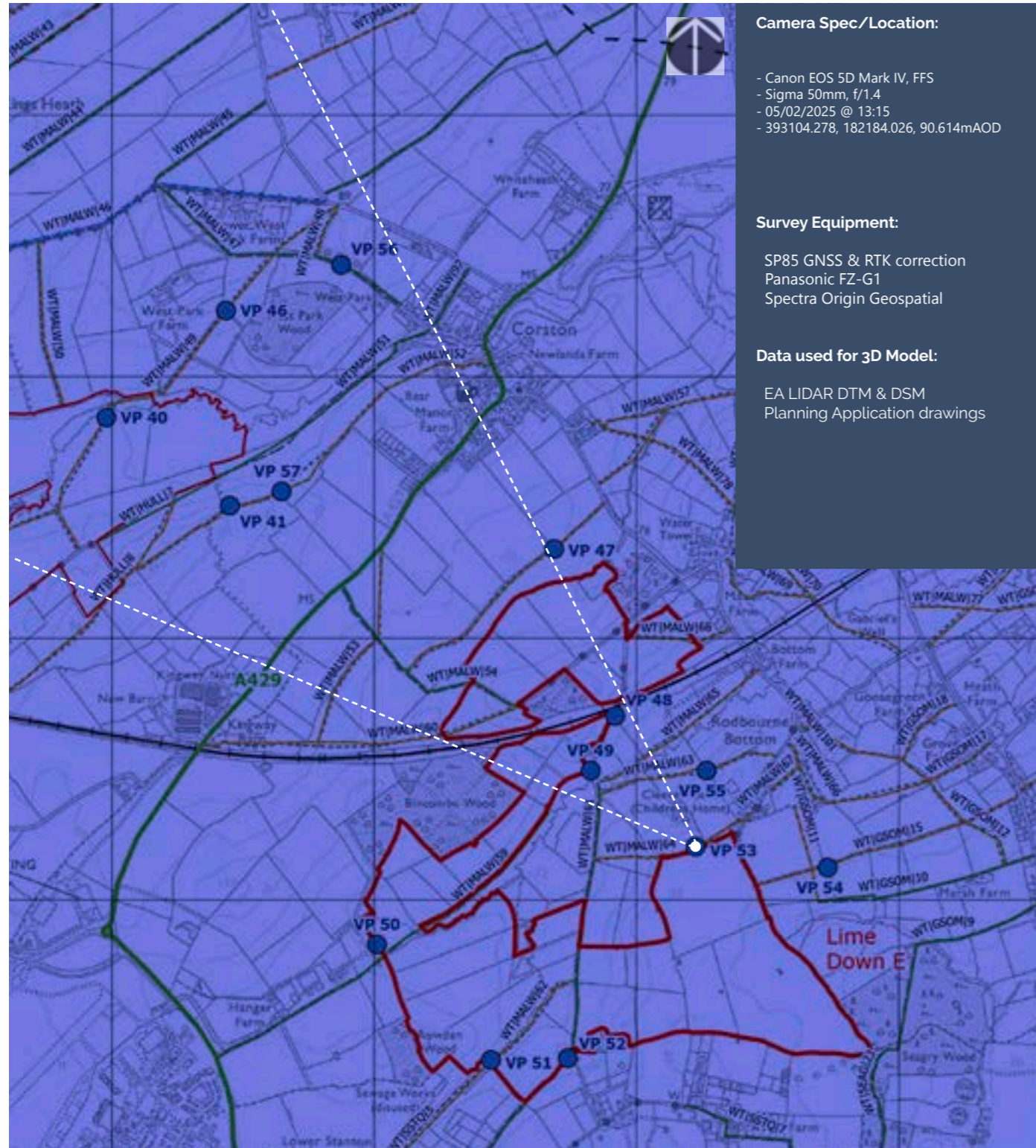

Crown Copyright and database rights 2025 Ordnance Survey 0100031673

Tripod:



50mm Lens Planar Projection (actual 49.6mm; 39.9 deg HFOV)



Point of Perspective

Point of Perspective

Point of Perspective

Point of Perspective

Viewpoint 53A Winter Single Frame 50mm Reference image

Camera Location:

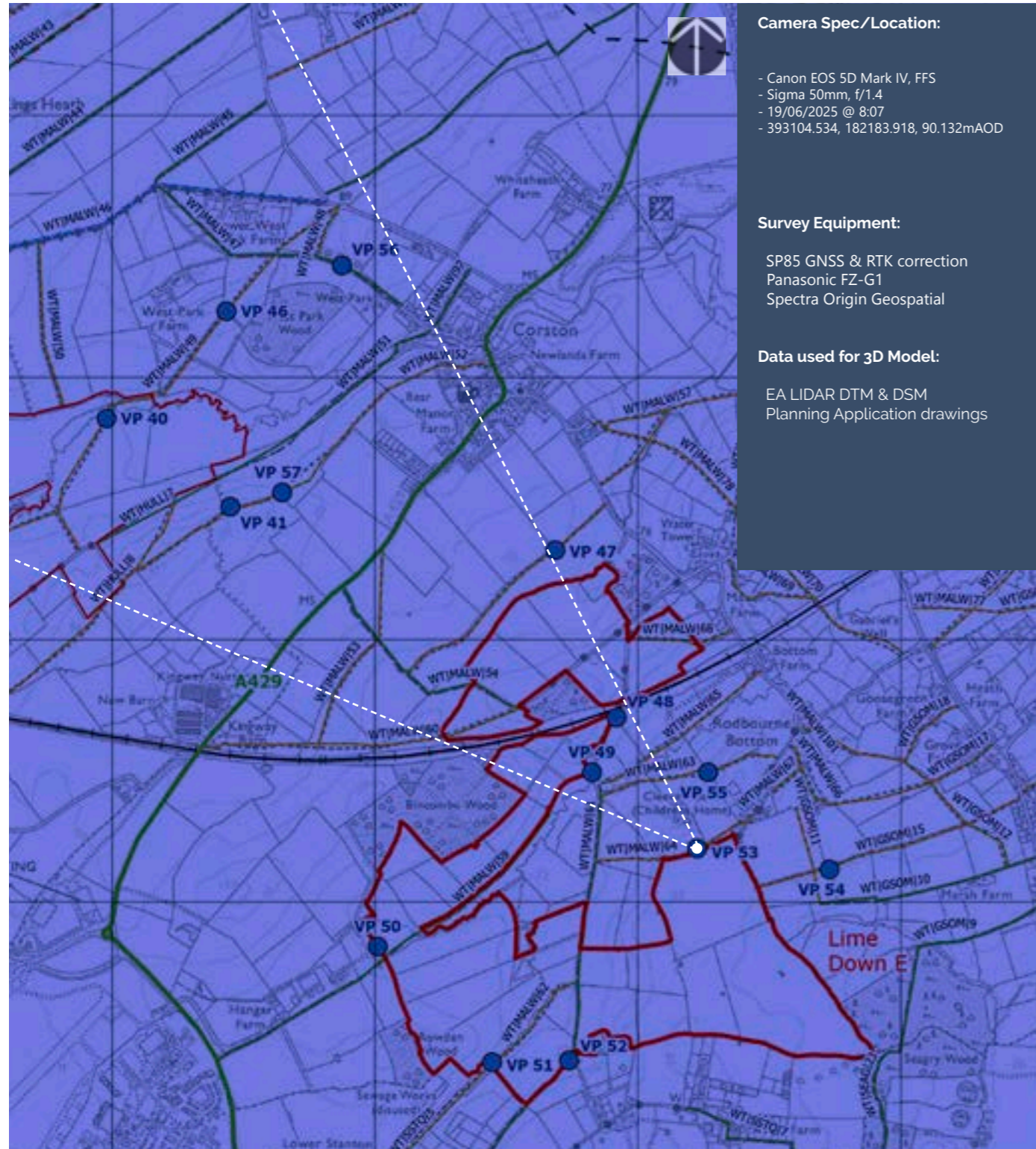

Camera Spec/Location:

- Canon EOS 5D Mark IV, FFS
- Sigma 50mm, f/1.4
- 19/06/2025 @ 8:07
- 393104.534, 182183.918, 90.132mAOD

Survey Equipment:

- SP85 GNSS & RTK correction
- Panasonic FZ-G1
- Spectra Origin Geospatial

Data used for 3D Model:

- EA LIDAR DTM & DSM
- Planning Application drawings

Ordnance Survey 2025 Copyright and database rights 0100031673

Tripod:



50mm Lens Planar Projection (actual 49.6mm; 39.9 deg HFOV)



Point of Perspective

Point of Perspective

Point of Perspective

Point of Perspective

Viewpoint 53A Summer Single Frame 50mm Reference image

Camera Location:

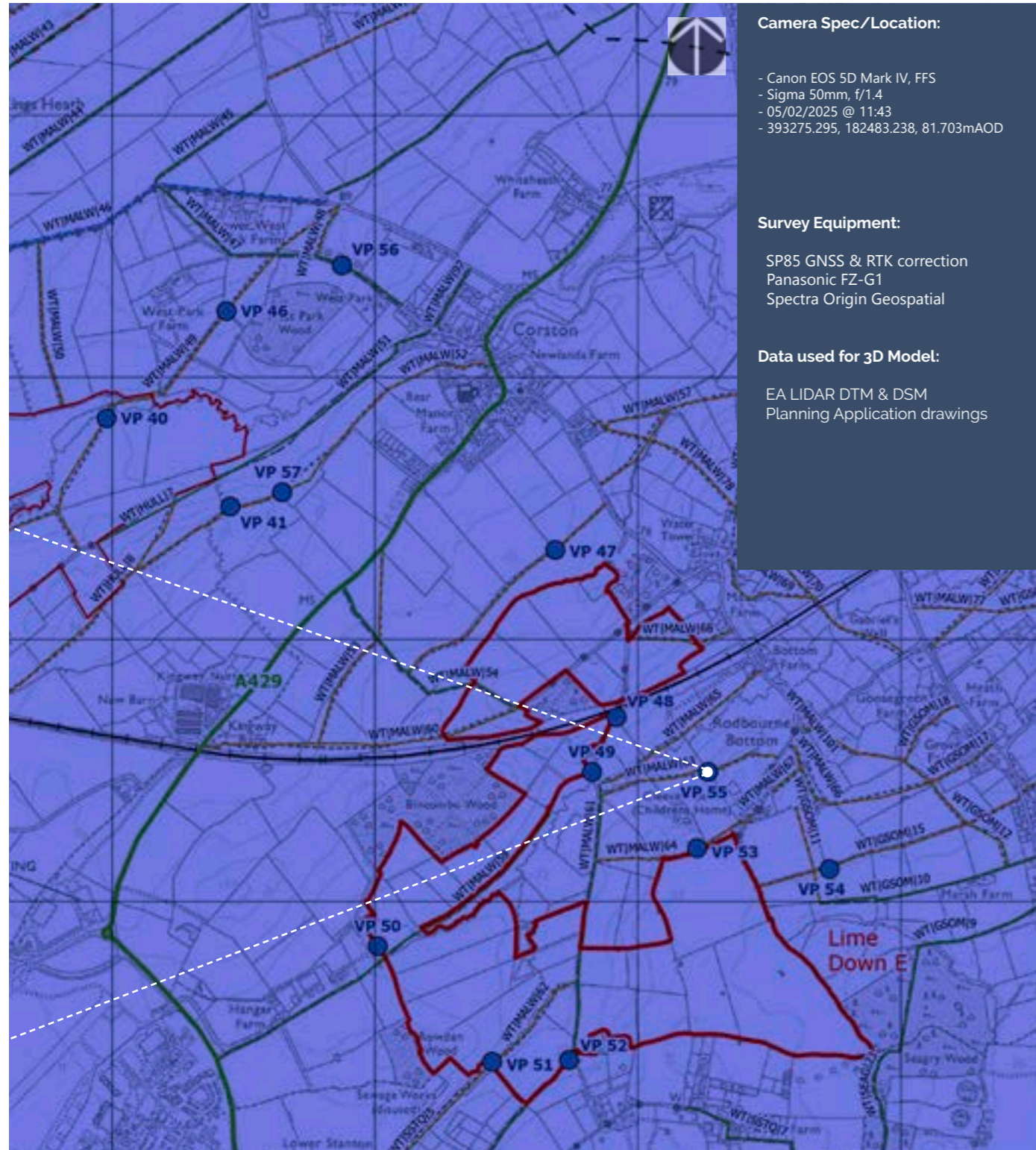

Camera Spec/Location:

- Canon EOS 5D Mark IV, FFS
- Sigma 50mm, f/1.4
- 05/02/2025 @ 11:43
- 393275.295, 182483.238, 81.703mAOD

Survey Equipment:

- SP85 GNSS & RTK correction
- Panasonic FZ-G1
- Spectra Origin Geospatial

Data used for 3D Model:

- EA LIDAR DTM & DSM
- Planning Application drawings

Crown Copyright and database rights 2025 Ordnance Survey 0100031673

Tripod:



50mm Lens Planar Projection (actual 49.6mm; 39.9 deg HFOV)



Point of Perspective

Point of Perspective

Point of Perspective

Point of Perspective

Viewpoint 55 Winter Single Frame 50mm Reference image

Camera Location:

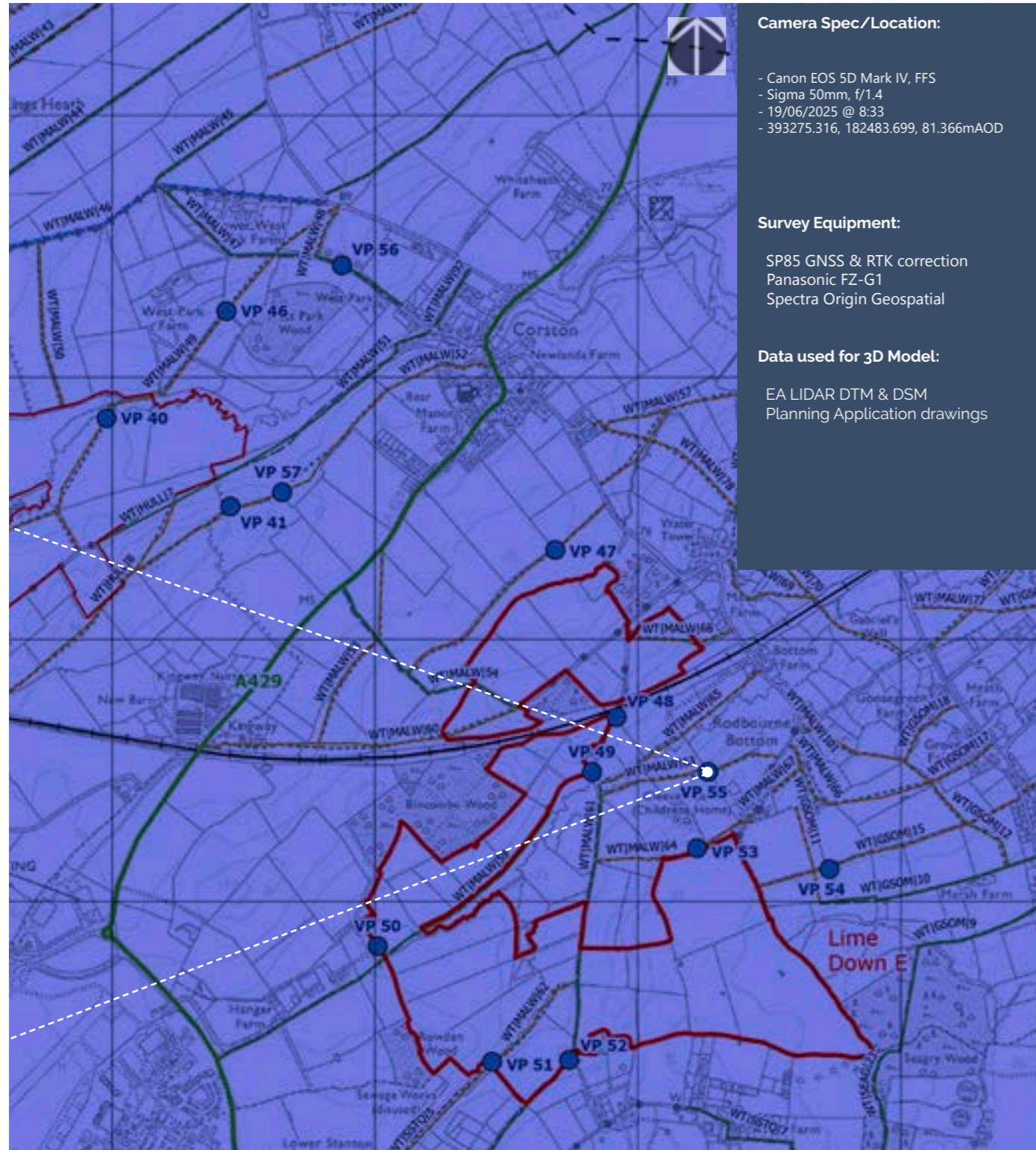

Own Copyright and database rights 2025 Ordnance Survey 0100031673

Tripod:



50mm Lens Planar Projection (actual 49.6mm; 39.9 deg HFOV)



Point of Perspective

Point of Perspective

Point of Perspective

Point of Perspective

Viewpoint 55 Summer Single Frame 50mm Reference image

Camera Location:

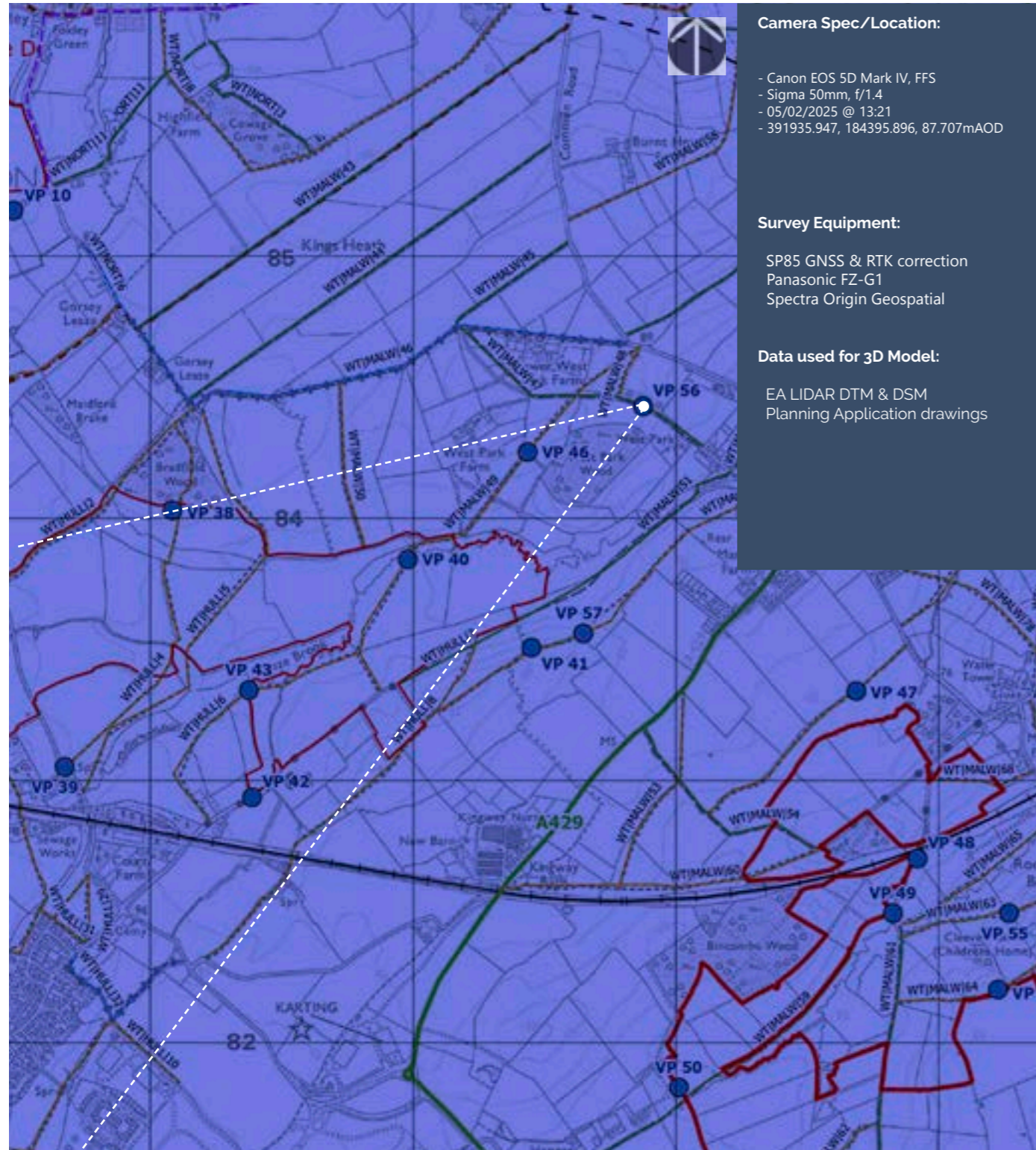

Camera Spec/Location:

- Canon EOS 5D Mark IV, FFS
- Sigma 50mm, f/1.4
- 05/02/2025 @ 13:21
- 391935.947, 184395.896, 87.707mAOD

Survey Equipment:

- SP85 GNSS & RTK correction
- Panasonic FZ-G1
- Spectra Origin Geospatial

Data used for 3D Model:

- EA LIDAR DTM & DSM
- Planning Application drawings

Corn Copyright and database rights 2025 Ordnance Survey 0100031673

Tripod:



50mm Lens Planar Projection (actual 49.6mm; 39.9 deg HFOV)



Point of Perspective

Point of Perspective

Point of Perspective

Point of Perspective

Viewpoint 56 Winter Single Frame 50mm Reference image

Camera Location:

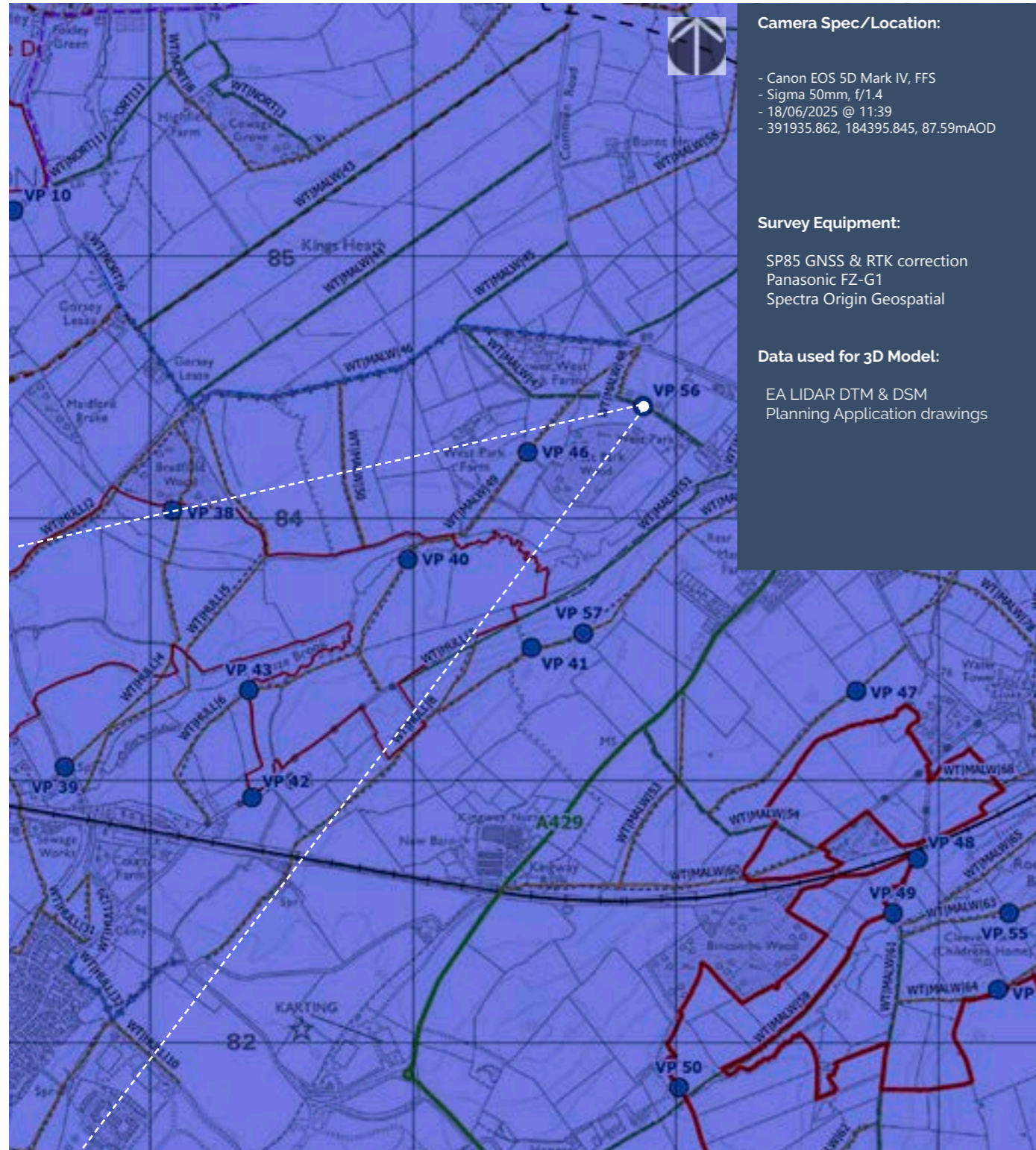

Corn Copyright and database rights 2025 Ordnance Survey 0100031673

Tripod:



50mm Lens Planar Projection (actual 49.6mm; 39.9 deg HFOV)

Point of Perspective



Point of Perspective

Point of Perspective

Point of Perspective

Viewpoint 56 Summer Single Frame 50mm Reference image

Camera Location:

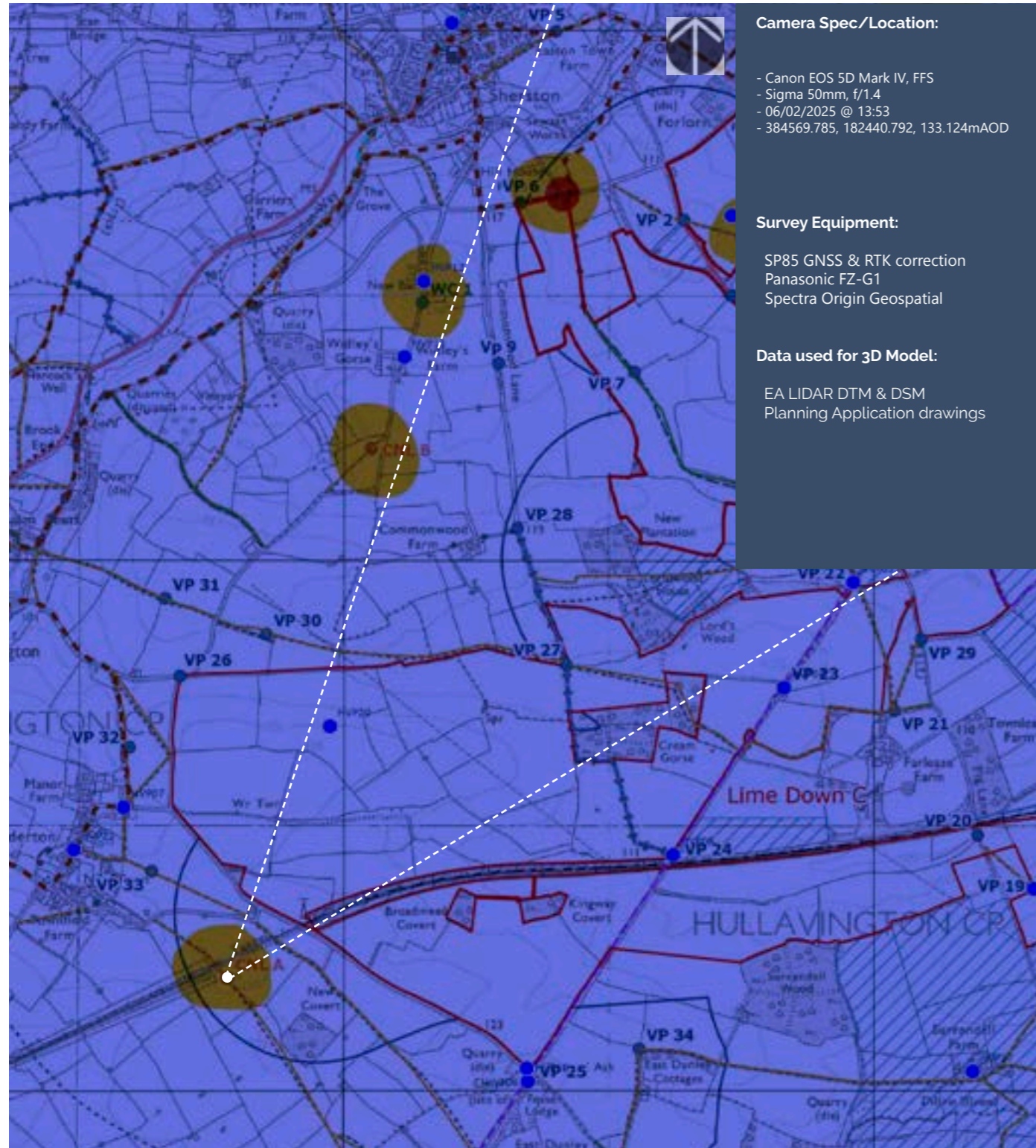

Crown Copyright and database rights 2025 Ordnance Survey 0100031673

Tripod:

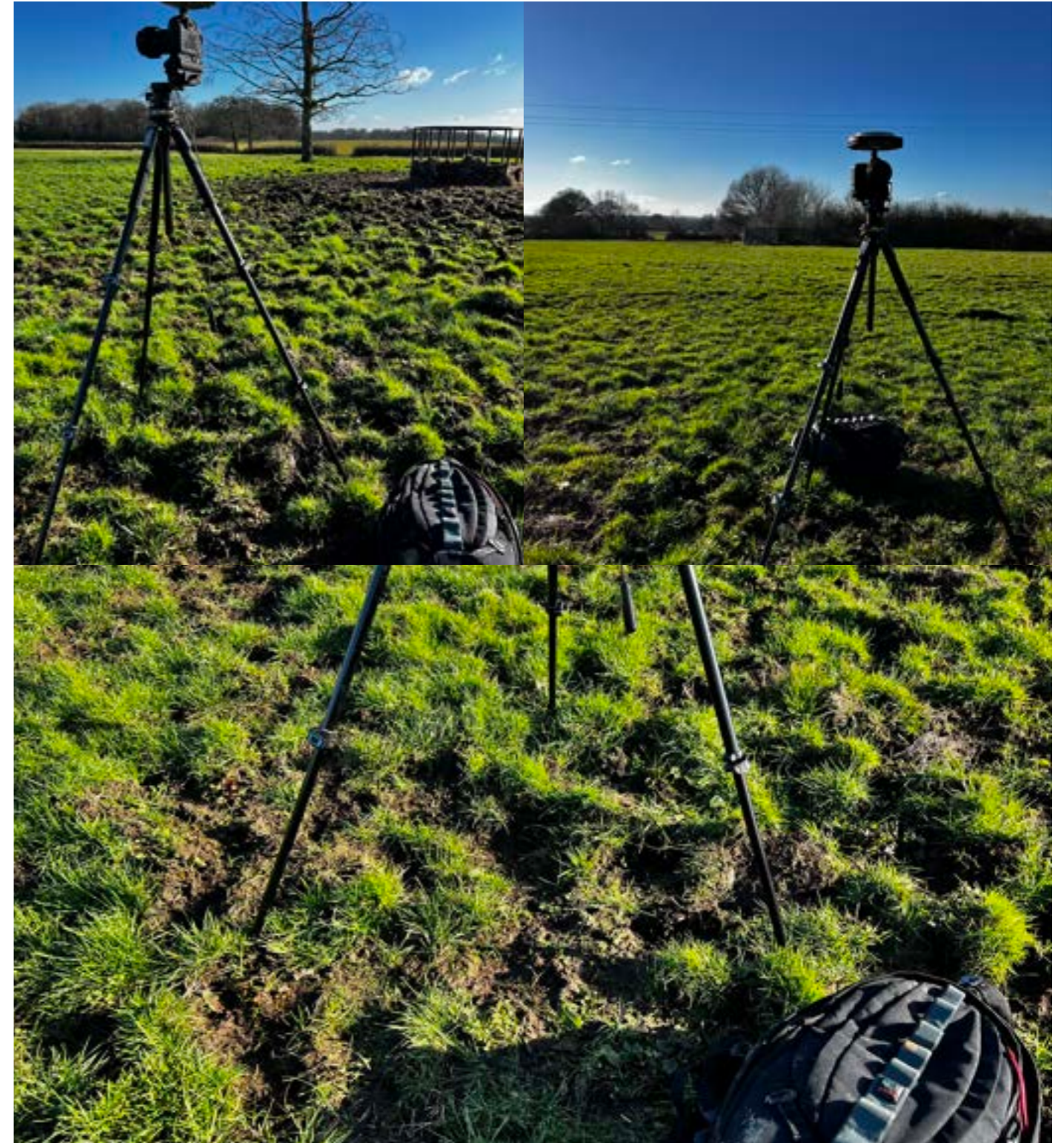

50mm Lens Planar Projection (actual 49.6mm; 39.9 deg HFOV)



Point of Perspective

Point of Perspective

Point of Perspective

Point of Perspective

Viewpoint CNL A Winter Single Frame 50mm Reference image

Limedown Solar Park

Camera Location:

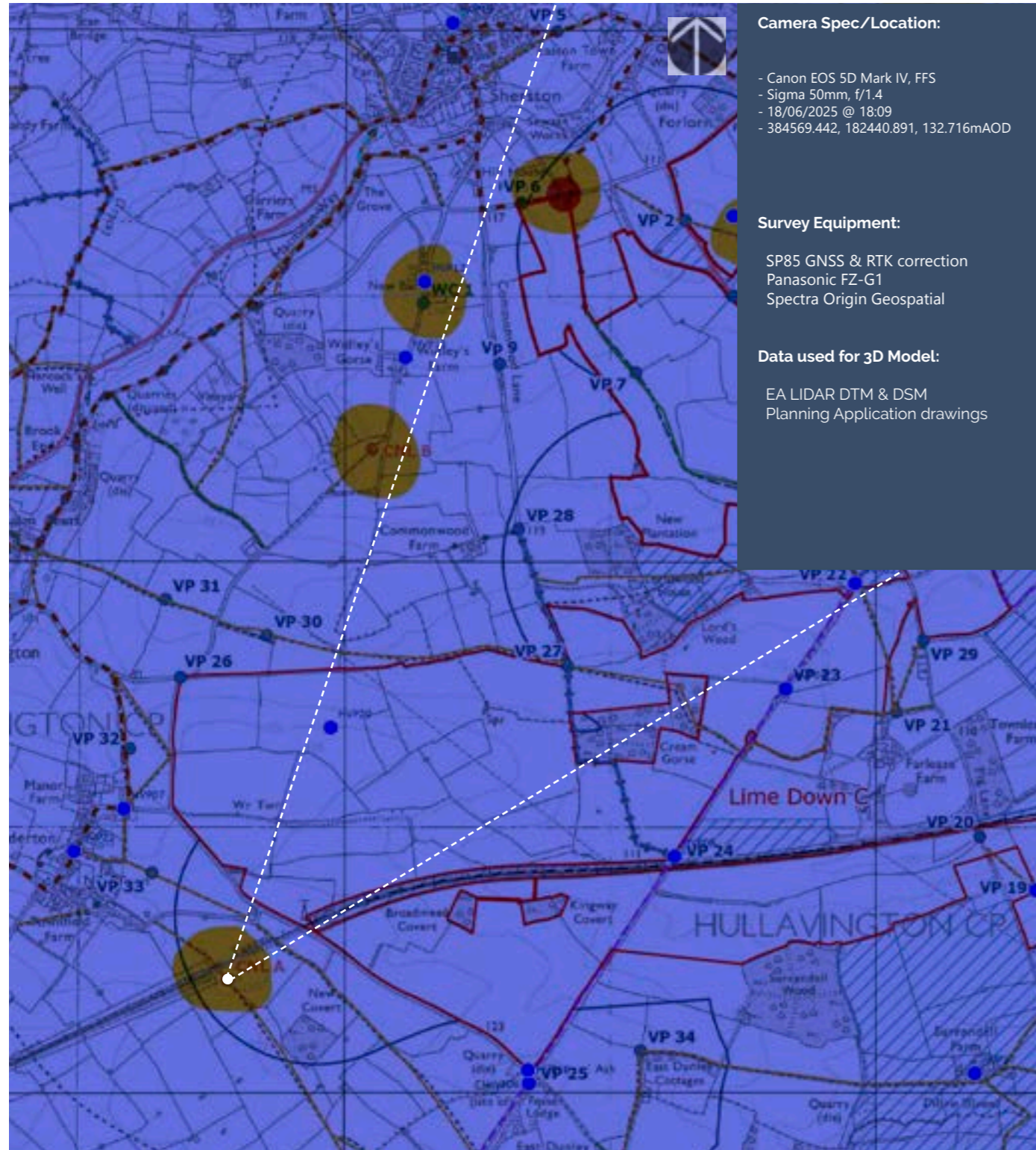

Crown Copyright and database rights 2025 Ordnance Survey 0100031673

Tripod:



50mm Lens Planar Projection (actual 49.6mm; 39.9 deg HFOV)



Point of Perspective

Point of Perspective

Point of Perspective

Point of Perspective

Viewpoint CNL A Summer Single Frame 50mm Reference image

Limedown Solar Park

Camera Location:

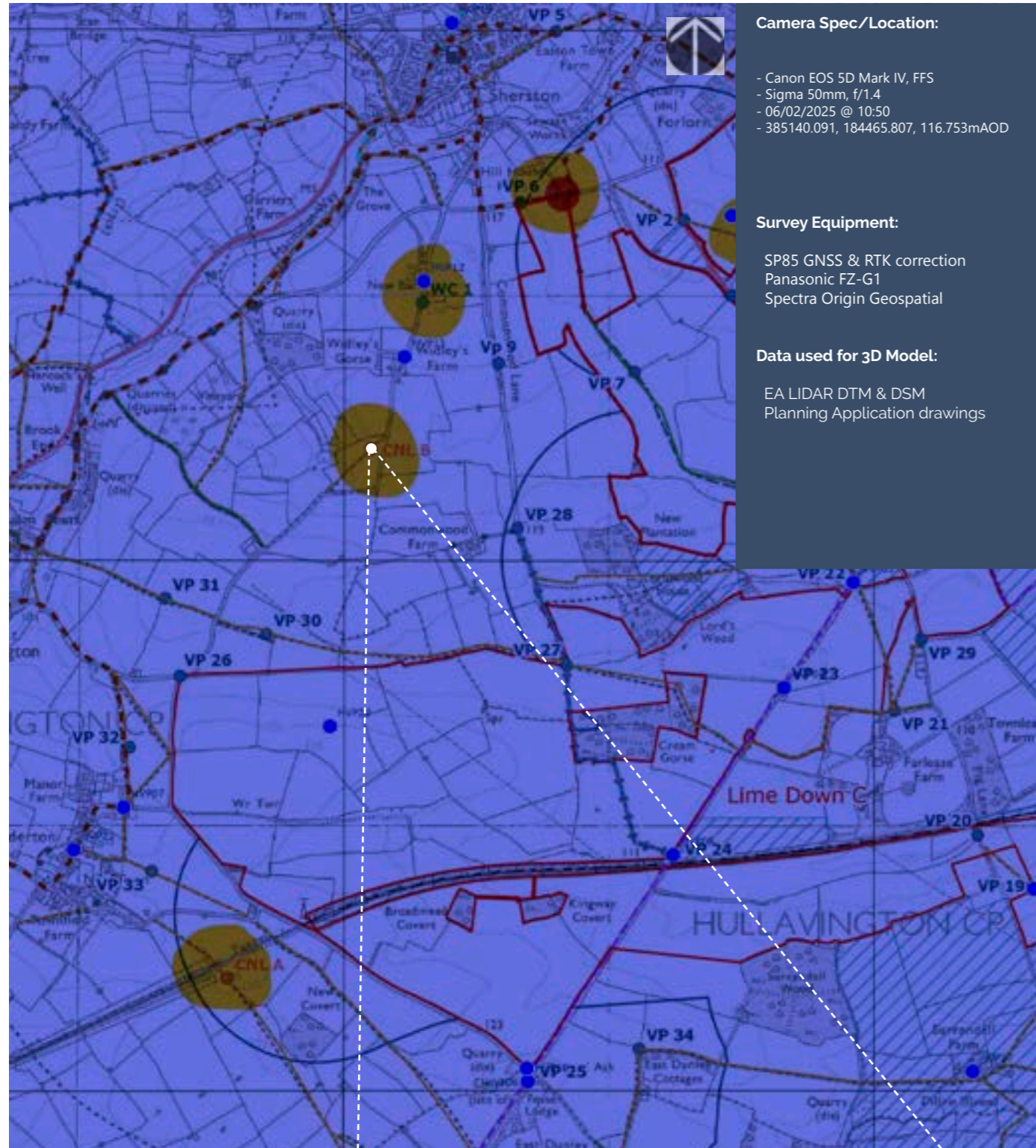

Own Copyright and database rights 2025 Ordnance Survey 0100031673

Tripod:



50mm Lens Planar Projection (actual 49.6mm; 39.9 deg HFOV)



Point of Perspective

Point of Perspective

Point of Perspective

Point of Perspective

Viewpoint CNL B Winter Single Frame 50mm Reference image

Camera Location:

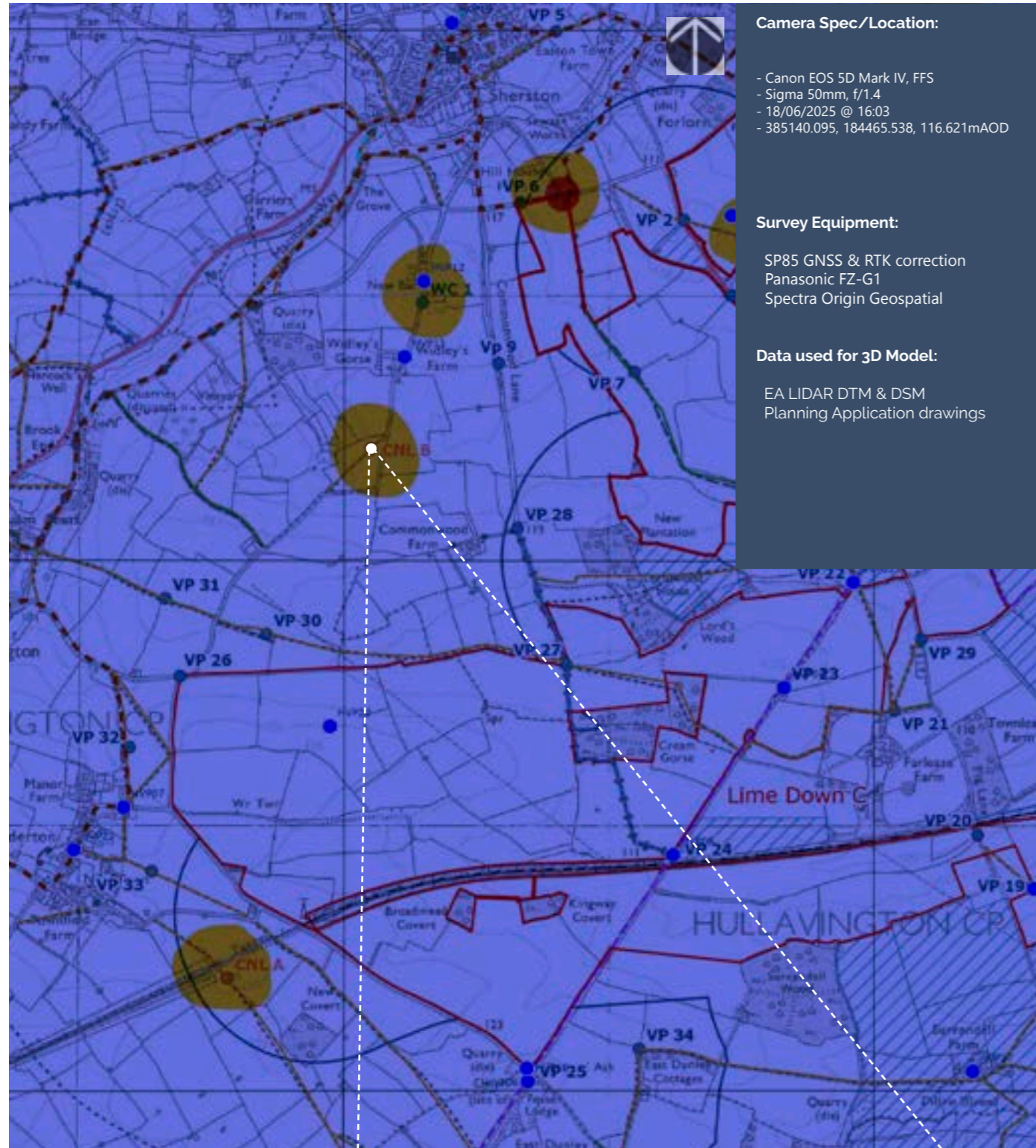

Camera Spec/Location:

- Canon EOS 5D Mark IV, FFS
- Sigma 50mm, f/1.4
- 18/06/2025 @ 16:03
- 385140.095, 184465.538, 116.621m AOD

Survey Equipment:

- SP85 GNSS & RTK correction
- Panasonic FZ-G1
- Spectra Origin Geospatial

Data used for 3D Model:

- EA LIDAR DTM & DSM
- Planning Application drawings

Tripod:



50mm Lens Planar Projection (actual 49.6mm; 39.9 deg HFOV)



Point of Perspective

Point of Perspective

Point of Perspective

Point of Perspective

Viewpoint CNL B Summer Single Frame 50mm Reference image

Camera Location:

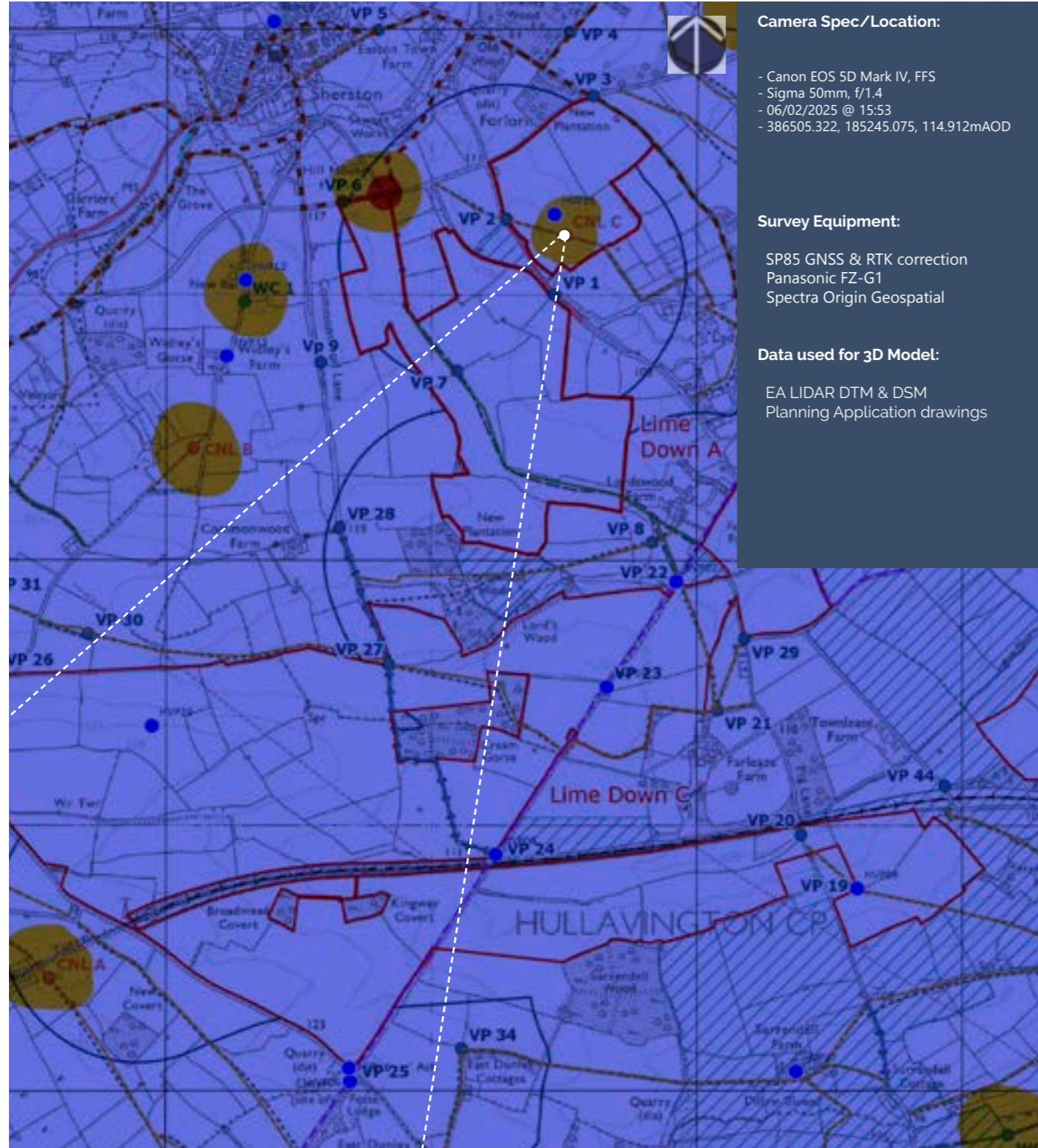

Own Copyright and database rights 2025 Ordnance Survey 0100031673

Tripod:



50mm Lens Planar Projection (actual 49.6mm; 39.9 deg HFOV)



Point of Perspective

Point of Perspective

Point of Perspective

Point of Perspective

Viewpoint CNL C Winter Single Frame 50mm Reference image

Camera Location:

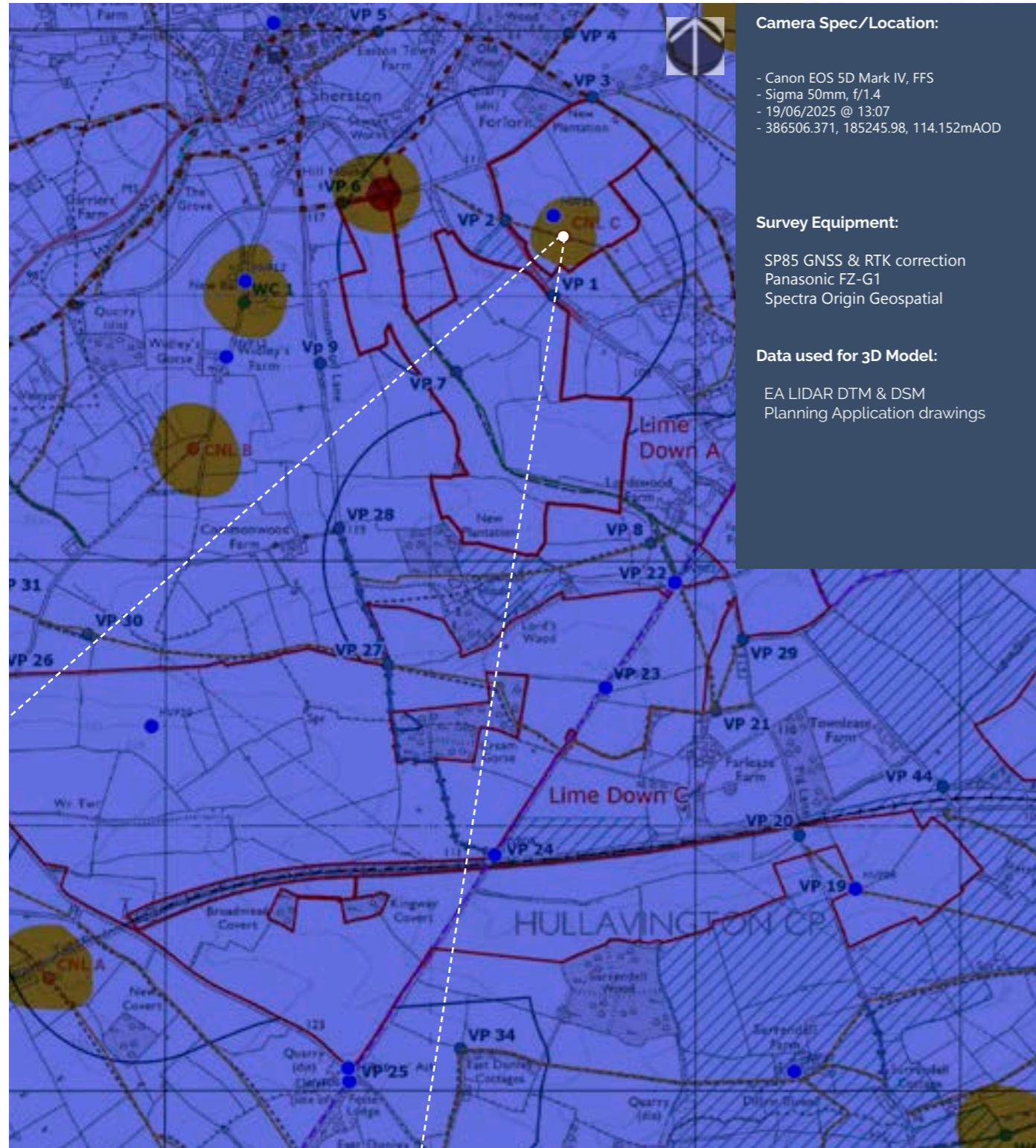

Own Copyright and database rights 2025 Ordnance Survey 0100031673

Tripod:



50mm Lens Planar Projection (actual 49.6mm; 39.9 deg HFOV)



Point of Perspective

Point of Perspective

Point of Perspective

Point of Perspective

Viewpoint CNL C Summer Single Frame 50mm Reference image

Limedown Solar Park

Camera Location:

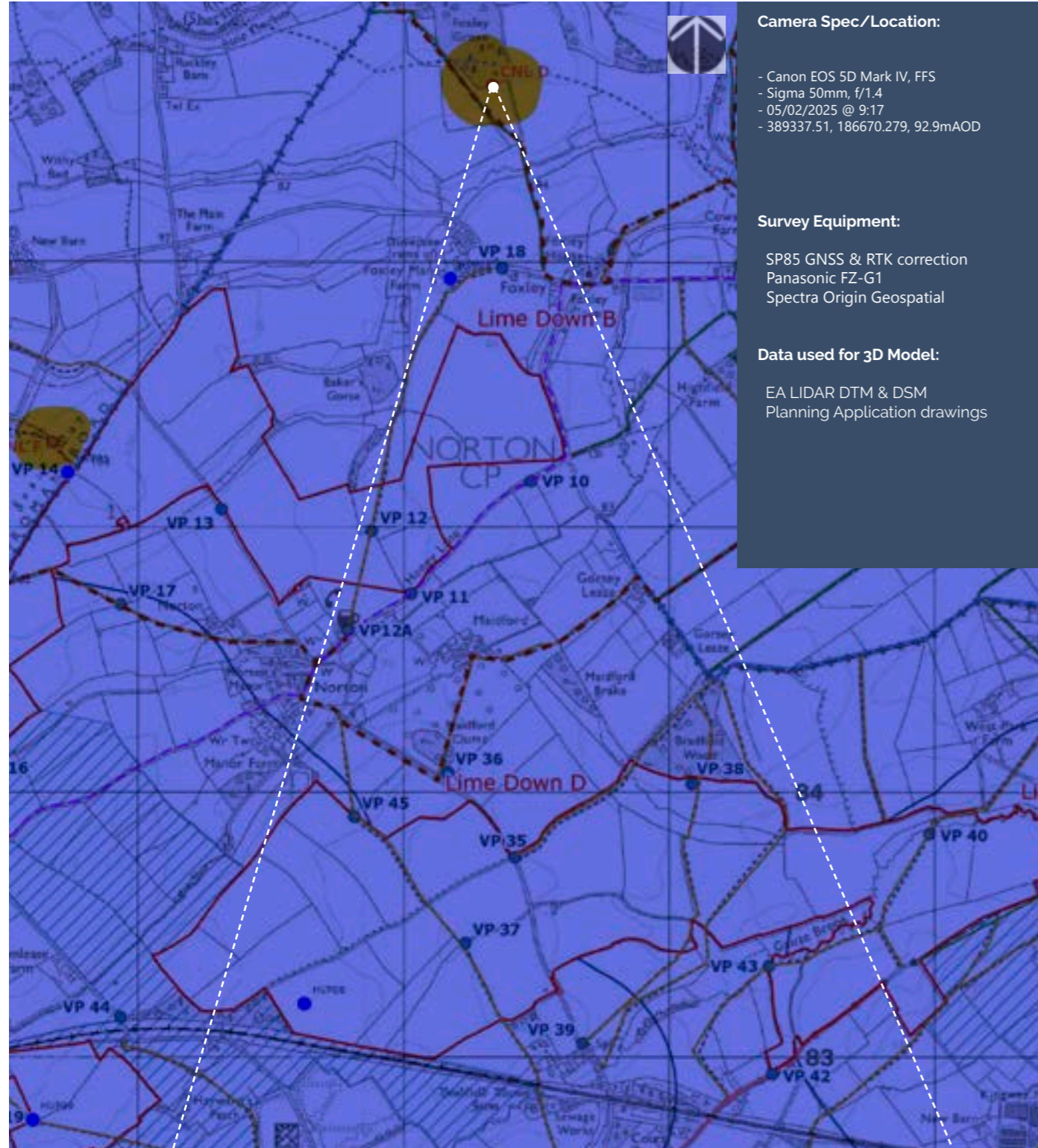

Ordnance Survey Crown Copyright and database rights 2025 Ordnance Survey 0100031673

Tripod:



50mm Lens Planar Projection (actual 49.6mm; 39.9 deg HFOV)



Point of Perspective

Point of Perspective

Point of Perspective

Point of Perspective

Viewpoint CNL D Winter Single Frame 50mm Reference image

Camera Location:

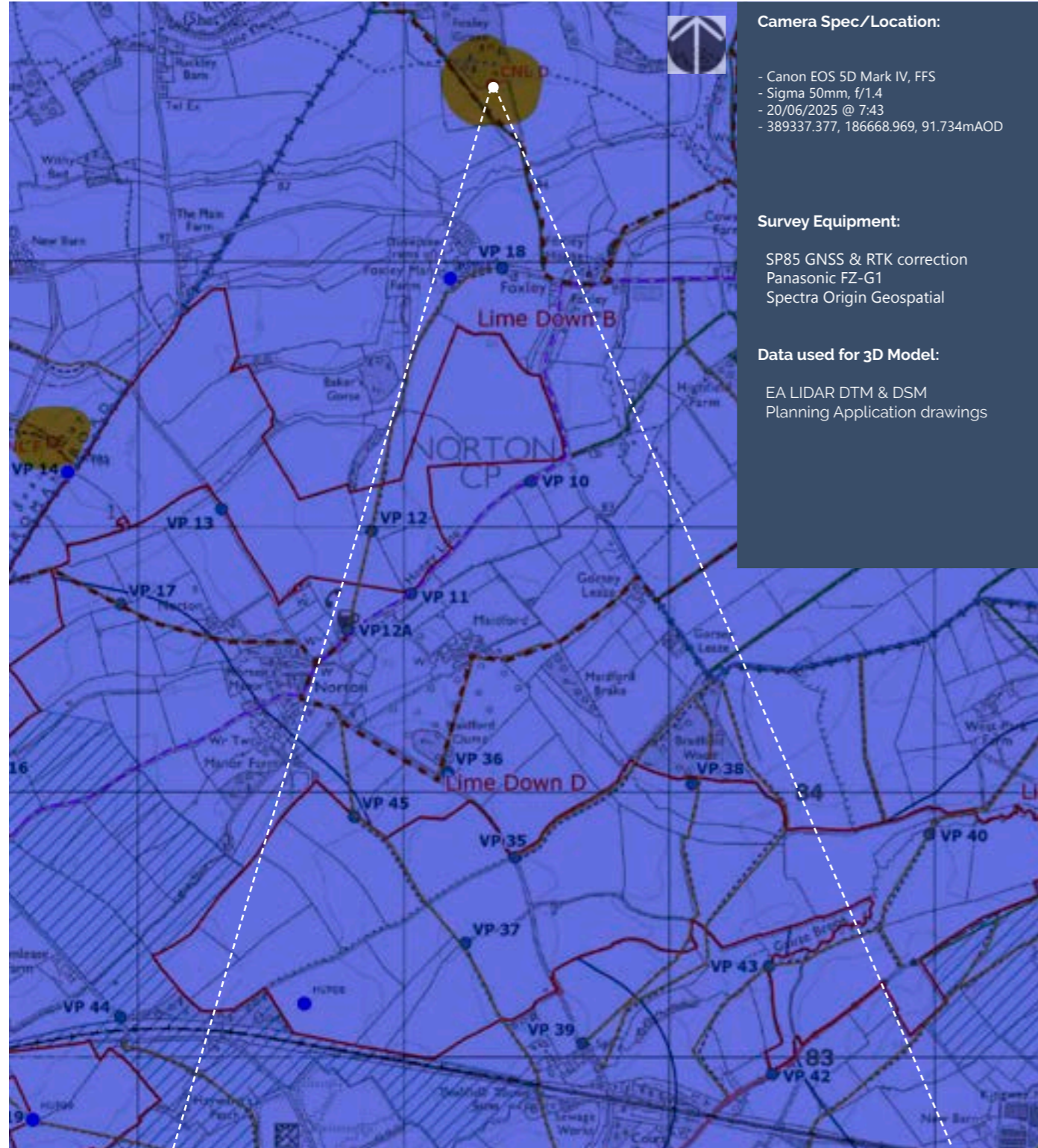

© Crown Copyright and database rights 2025 Ordnance Survey 0100031673

Tripod:



50mm Lens Planar Projection (actual 49.6mm; 39.9 deg HFOV)



Point of Perspective

Point of Perspective

Point of Perspective

Point of Perspective

Viewpoint CNL D Summer Single Frame 50mm Reference image

Limedown Solar Park

Camera Location:

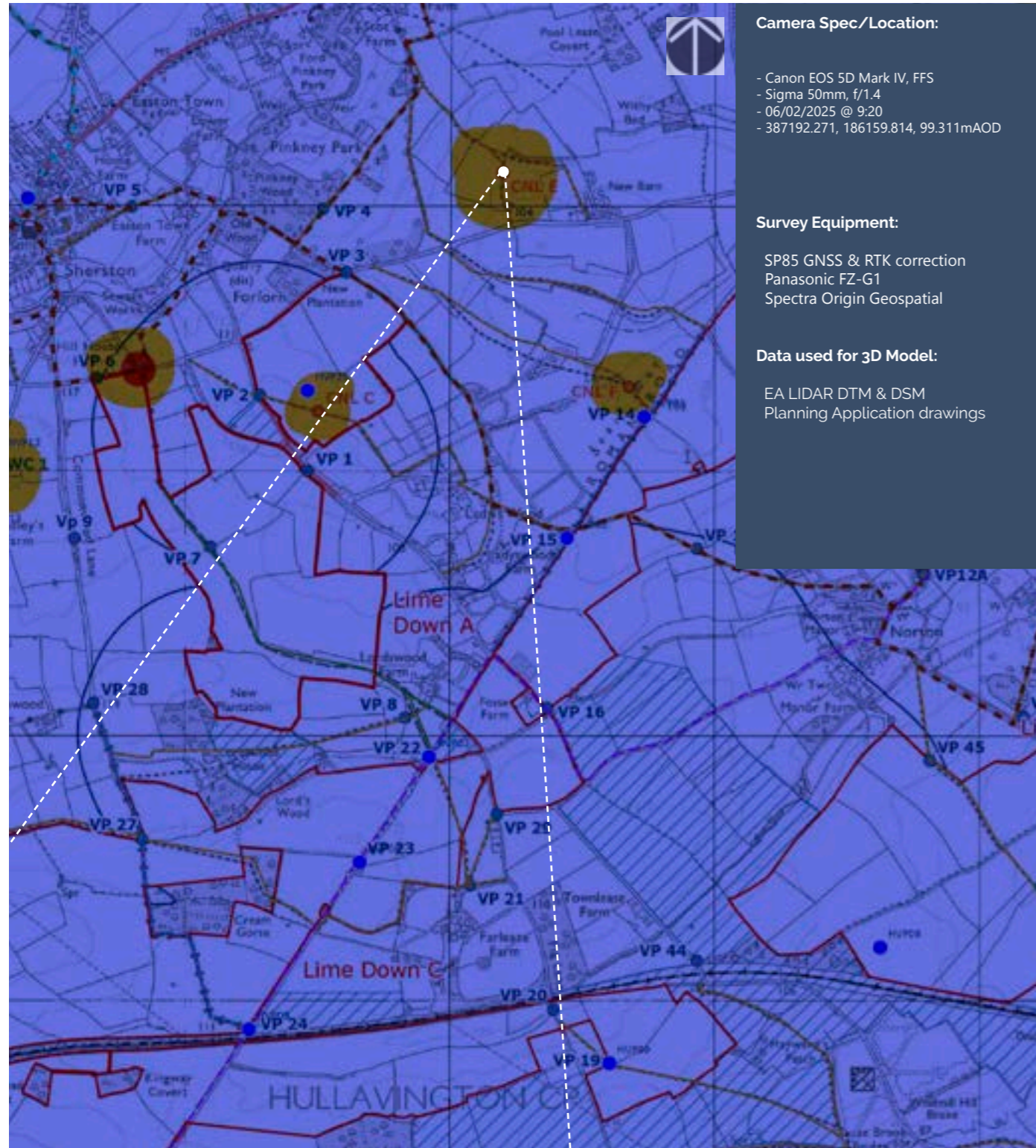

© Crown Copyright and database rights 2025 Ordnance Survey 0100031673

Tripod:



50mm Lens Planar Projection (actual 49.6mm; 39.9 deg HFOV)



Point of Perspective

Point of Perspective

Point of Perspective

Point of Perspective

Viewpoint CNL E Winter Single Frame 50mm Reference image

Camera Location:

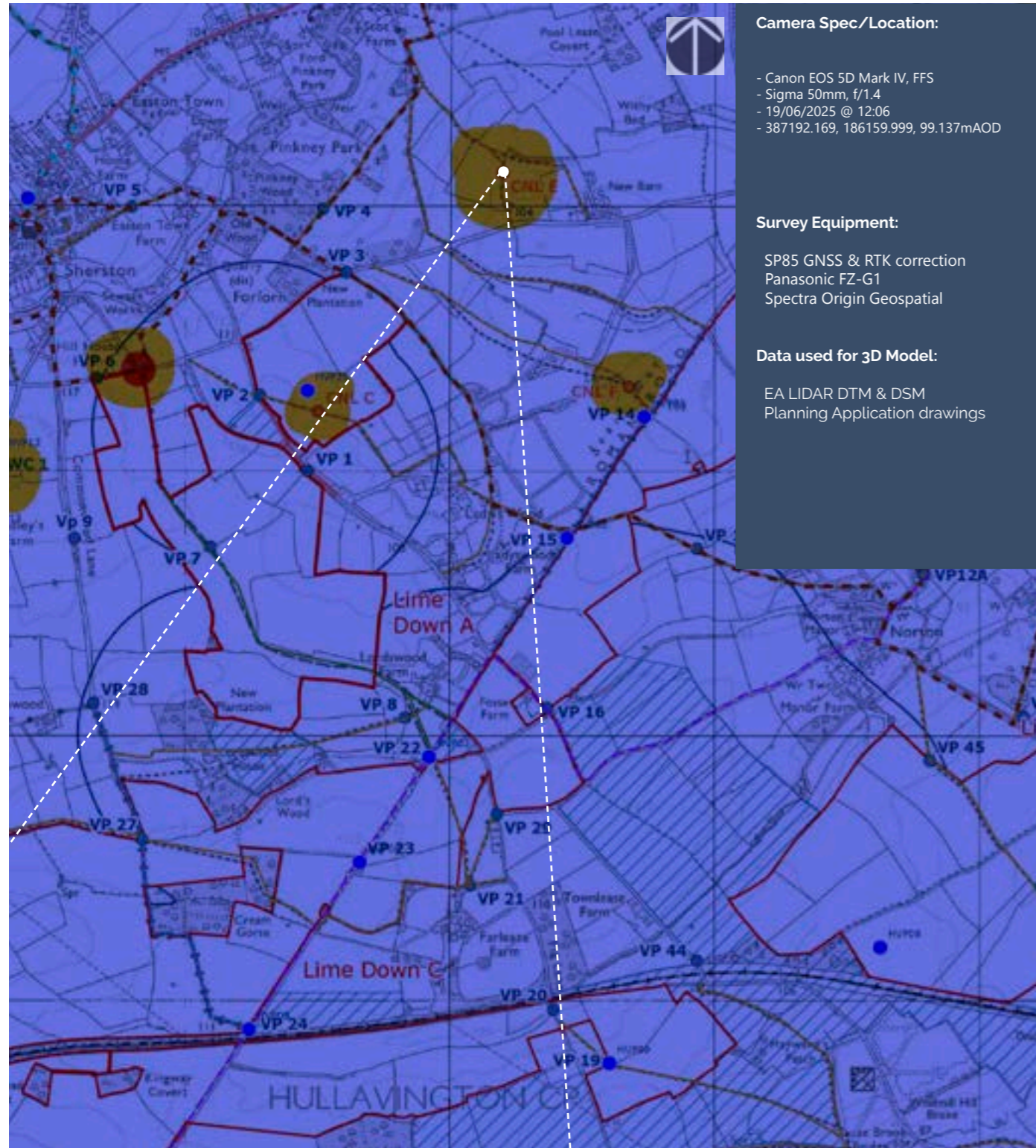

Camera Spec/Location:

- Canon EOS 5D Mark IV, FFS
- Sigma 50mm, f/1.4
- 19/06/2025 @ 12:06
- 387192.169, 186159.999, 99.137mAOD

Survey Equipment:

- SP85 GNSS & RTK correction
- Panasonic FZ-G1
- Spectra Origin Geospatial

Data used for 3D Model:

- EA LIDAR DTM & DSM
- Planning Application drawings

Crown Copyright and database rights 2025 Ordnance Survey 0100031673

Tripod:



50mm Lens Planar Projection (actual 49.6mm; 39.9 deg HFOV)



Point of Perspective

Point of Perspective

Point of Perspective

Point of Perspective

Viewpoint CNL E Summer Single Frame 50mm Reference image

Limedown Solar Park

Camera Location:

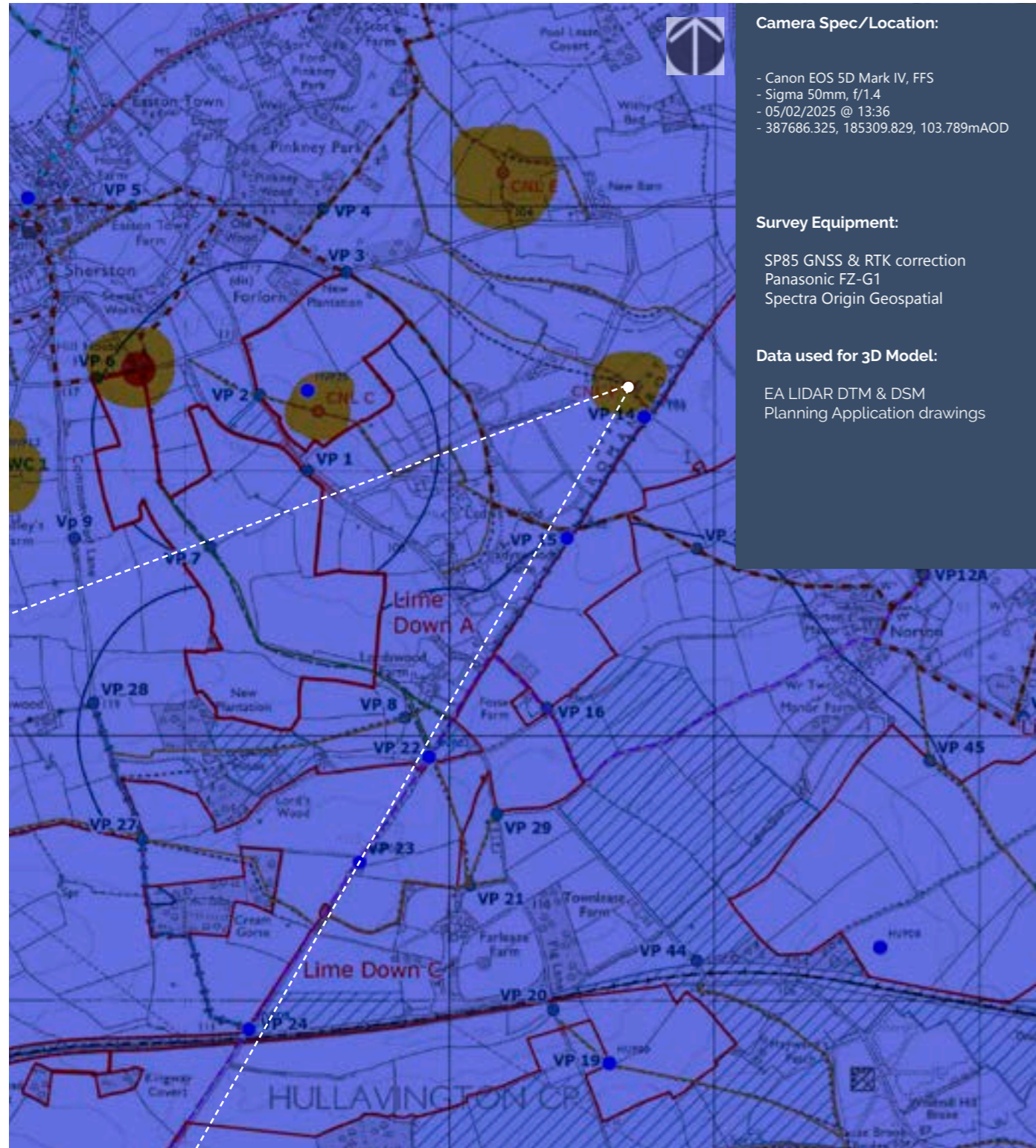

© Crown Copyright and database rights 2025 Ordnance Survey 0100031673

Tripod:



50mm Lens Planar Projection (actual 49.6mm; 39.9 deg HFOV)



Point of Perspective

Point of Perspective

Point of Perspective

Point of Perspective

Viewpoint CNL F Winter Single Frame 50mm Reference image

Camera Location:

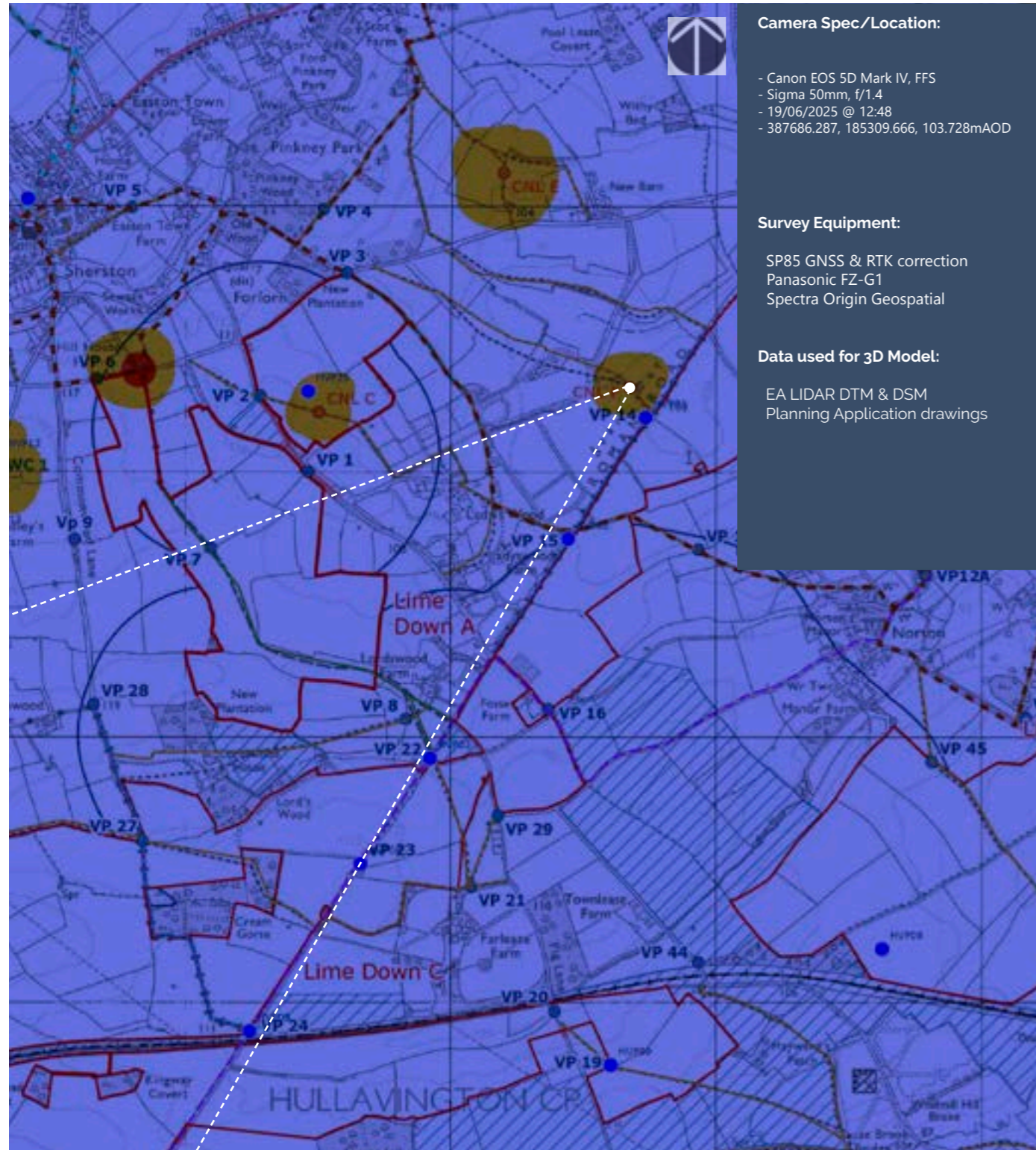

Own Copyright and database rights 2025 Ordnance Survey 0100031673

Tripod:



50mm Lens Planar Projection (actual 49.6mm; 39.9 deg HFOV)



Point of Perspective

Point of Perspective

Point of Perspective

Point of Perspective

Viewpoint CNL F Summer Single Frame 50mm Reference image

Camera Location:

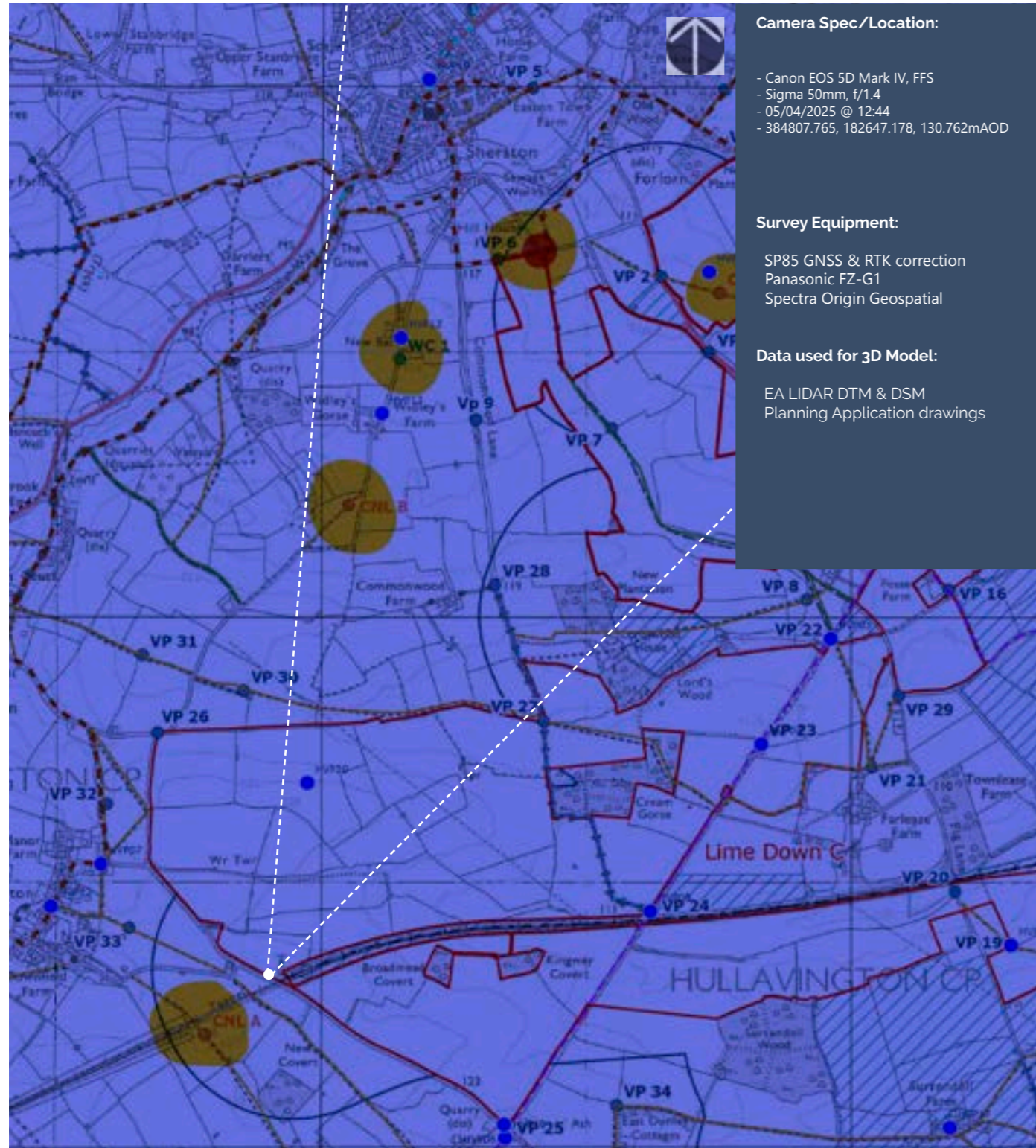

Copyright and database rights 2025 Ordnance Survey 0100031673

Tripod:



50mm Lens Planar Projection (actual 49.6mm; 39.9 deg HFOV)



Point of Perspective

Point of Perspective

Point of Perspective

Point of Perspective

Viewpoint CNL G Winter Single Frame 50mm Reference image

Limedown Solar Park

Camera Location:

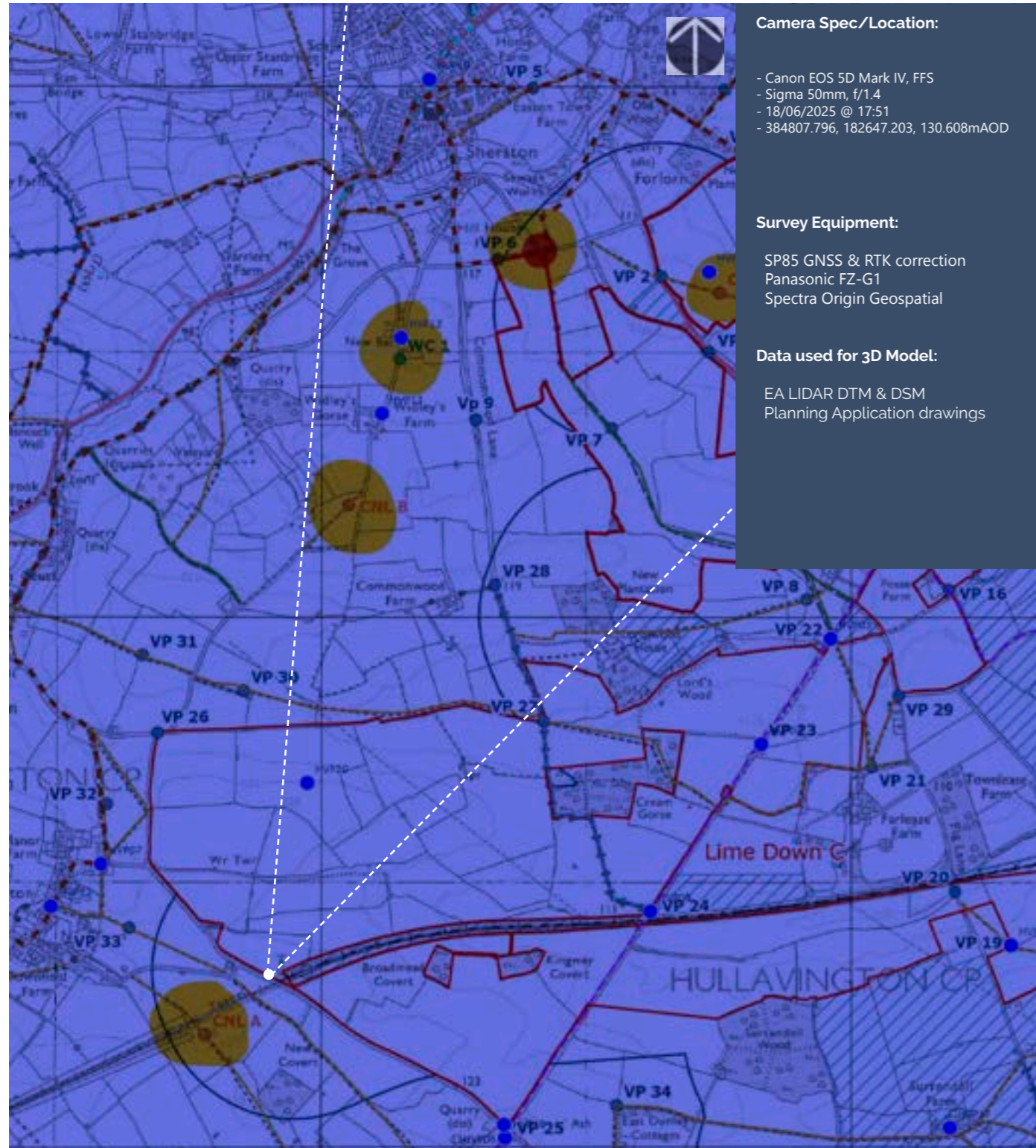

Camera Spec/Location:

- Canon EOS 5D Mark IV, FFS
- Sigma 50mm, f/1.4
- 18/06/2025 @ 17:51
- 384807.796, 182647.203, 130.608mAOD

Survey Equipment:

- SP85 GNSS & RTK correction
- Panasonic FZ-G1
- Spectra Origin Geospatial

Data used for 3D Model:

- EA LIDAR DTM & DSM
- Planning Application drawings

Cown Copyright and database rights 2025 Ordnance Survey 0100031673

Tripod:



50mm Lens Planar Projection (actual 49.6mm; 39.9 deg HFOV)



Point of Perspective

Viewpoint CNL G Summer Single Frame 50mm Reference image

Limedown Solar Park

Camera Location:

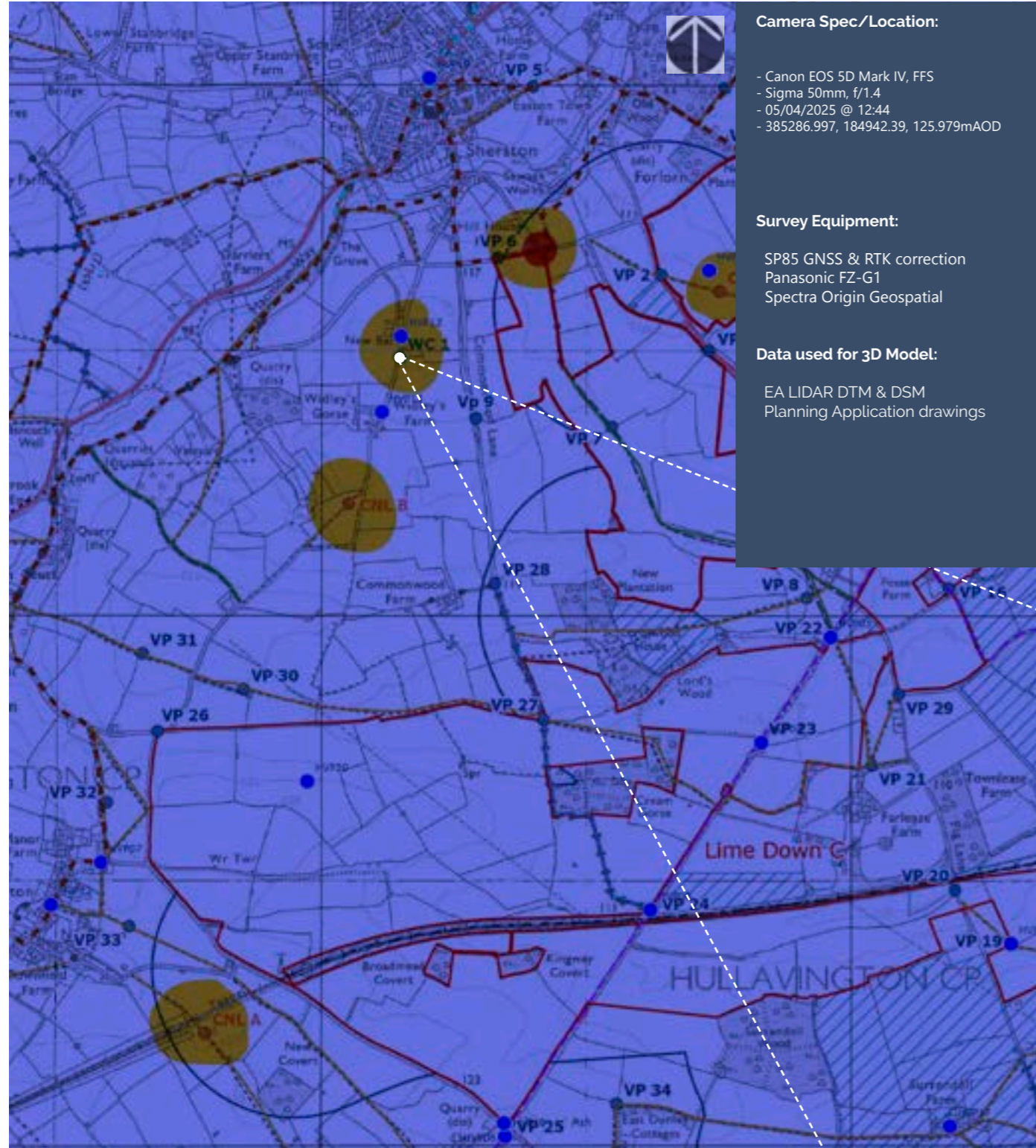

Camera Spec/Location:

- Canon EOS 5D Mark IV, FFS
- Sigma 50mm, f/1.4
- 05/04/2025 @ 12:44
- 385286.997, 184942.39, 125.979mAOD

Survey Equipment:

- SP85 GNSS & RTK correction
- Panasonic FZ-G1
- Spectra Origin Geospatial

Data used for 3D Model:

- EA LIDAR DTM & DSM
- Planning Application drawings

Copyright and database rights 2025 Ordnance Survey 0100031673

Tripod:



50mm Lens Planar Projection (actual 49.6mm; 39.9 deg HFOV)



Point of Perspective

Point of Perspective

Point of Perspective

Point of Perspective

Viewpoint WC1 Winter Single Frame 50mm Reference image

Camera Location:

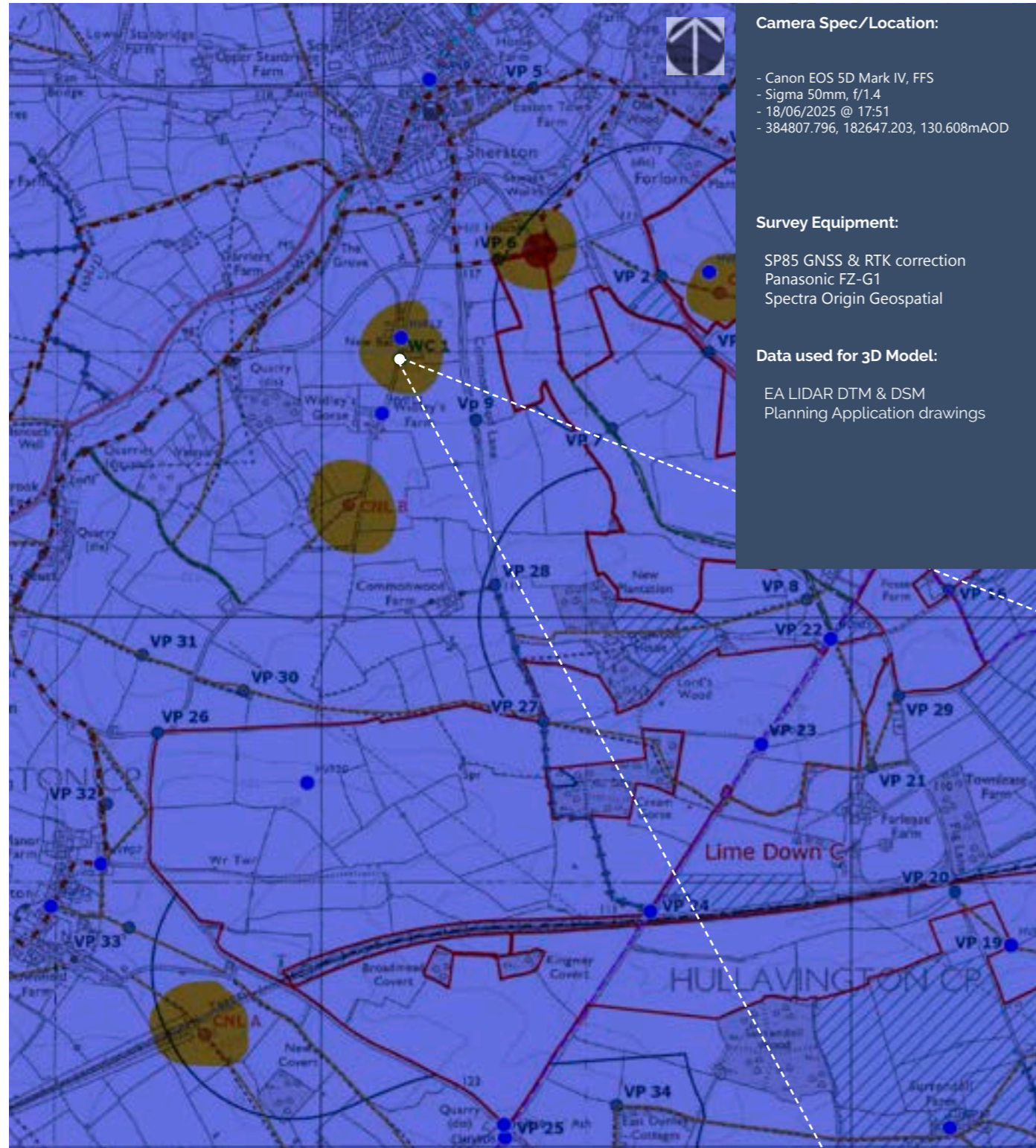

Camera Spec/Location:

- Canon EOS 5D Mark IV, FFS
- Sigma 50mm, f/1.4
- 18/06/2025 @ 17:51
- 384807.796, 182647.203, 130.608mAOD

Survey Equipment:

- SP85 GNSS & RTK correction
- Panasonic FZ-G1
- Spectra Origin Geospatial

Data used for 3D Model:

- EA LIDAR DTM & DSM
- Planning Application drawings

Copyright and database rights 2025 Ordnance Survey 0100031673

Tripod:



50mm Lens Planar Projection (actual 49.6mm; 39.9 deg HFOV)

Point of Perspective



Point of Perspective

Point of Perspective

Point of Perspective

Viewpoint WC1 Summer Single Frame 50mm Reference image

Camera Location:

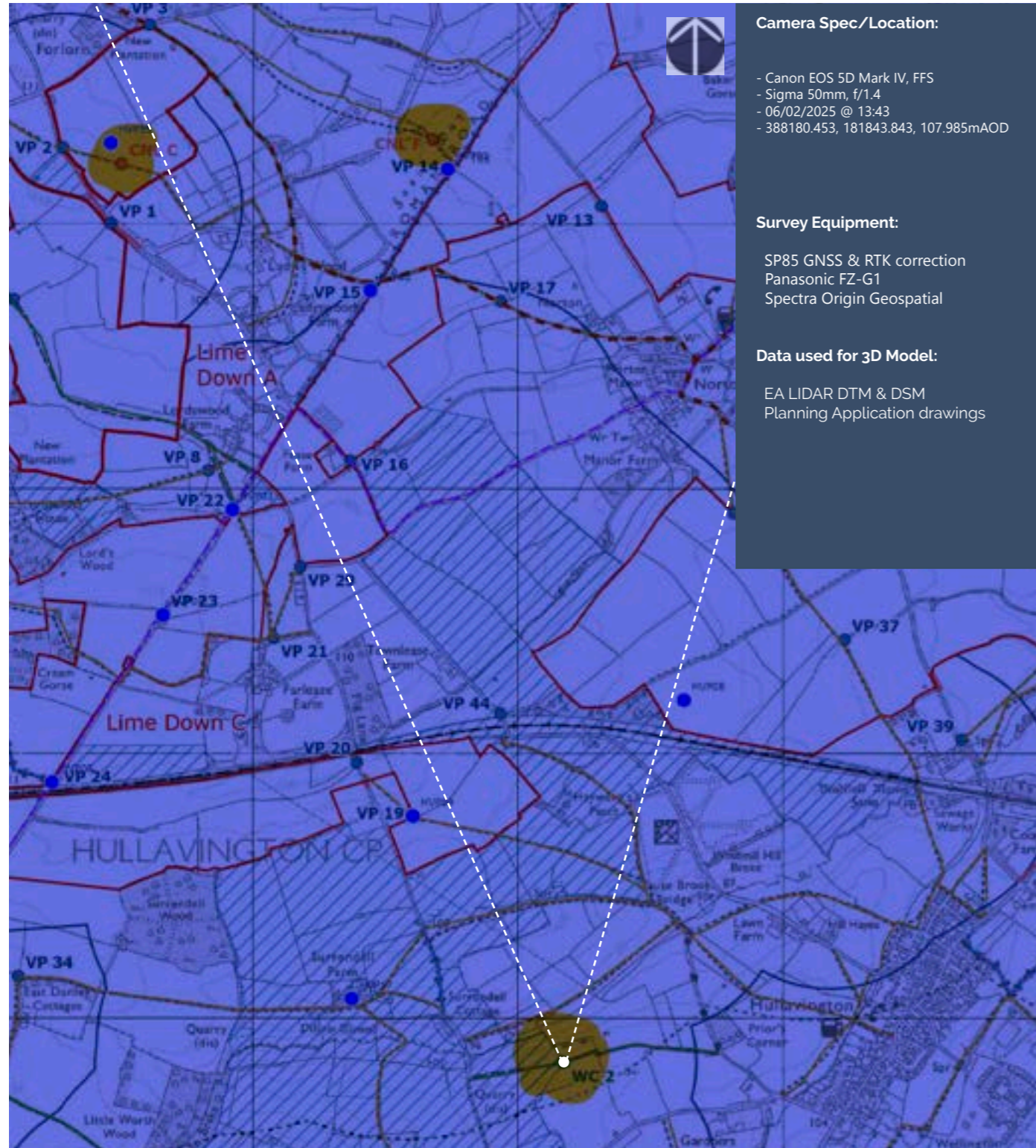

Camera Spec/Location:

- Canon EOS 5D Mark IV, FFS
- Sigma 50mm, f/1.4
- 06/02/2025 @ 13:43
- 388180.453, 181843.843, 107.985mAOD

Survey Equipment:

- SP85 GNSS & RTK correction
- Panasonic FZ-G1
- Spectra Origin Geospatial

Data used for 3D Model:

- EA LIDAR DTM & DSM
- Planning Application drawings

Own Copyright and database rights 2025 Ordnance Survey 0100031673

Tripod:



50mm Lens Planar Projection (actual 49.6mm; 39.9 deg HFOV)



Point of Perspective

Point of Perspective

Point of Perspective

Point of Perspective

Viewpoint WC2 Winter Single Frame 50mm Reference image

Camera Location:

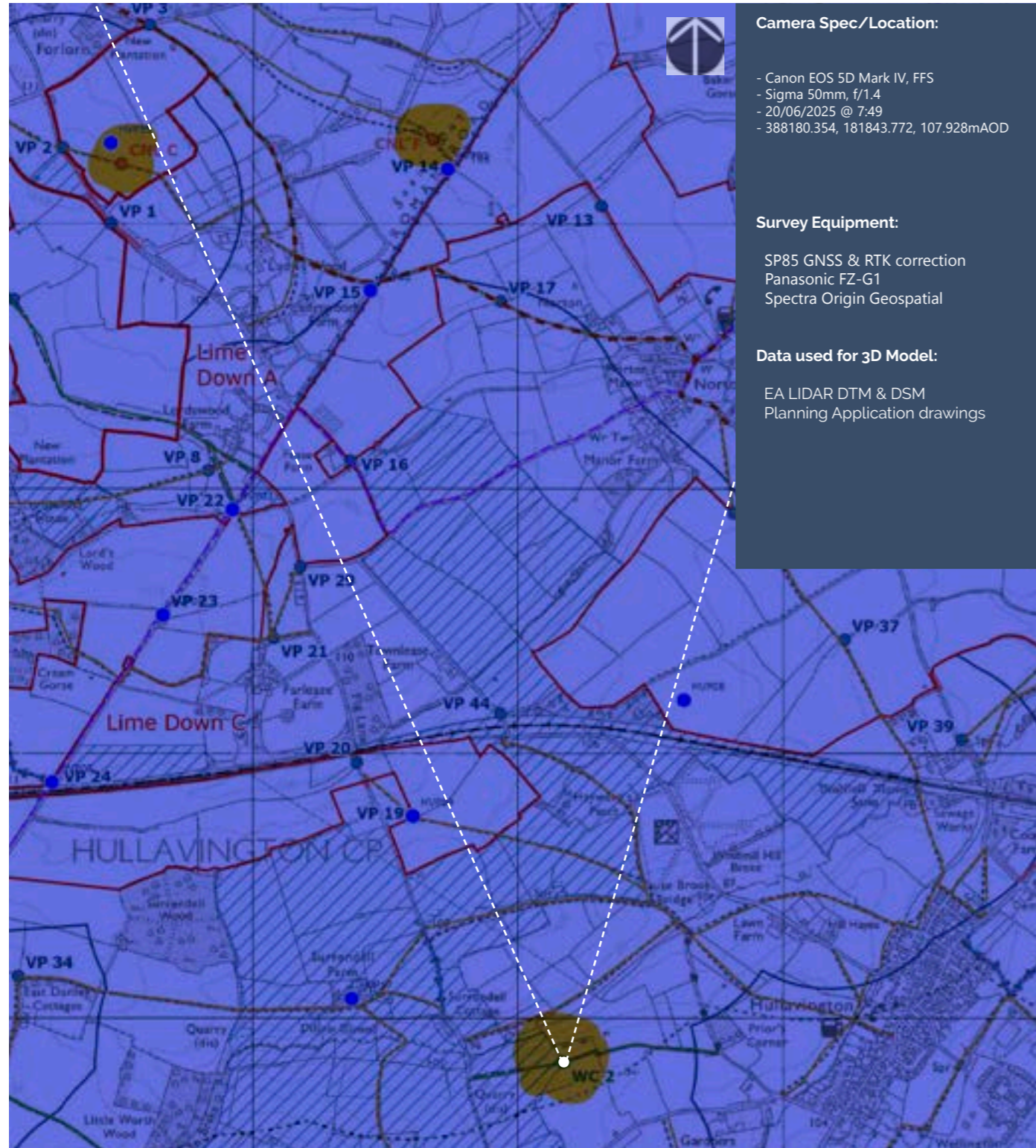

Camera Spec/Location:

- Canon EOS 5D Mark IV, FFS
- Sigma 50mm, f/1.4
- 20/06/2025 @ 7:49
- 388180.354, 181843.772, 107.928mAOD

Survey Equipment:

- SP85 GNSS & RTK correction
- Panasonic FZ-G1
- Spectra Origin Geospatial

Data used for 3D Model:

- EA LIDAR DTM & DSM
- Planning Application drawings

Own Copyright and database rights 2025 Ordnance Survey 0100031673

Tripod:



50mm Lens Planar Projection (actual 49.6mm; 39.9 deg HFOV)



Point of Perspective

Point of Perspective

Point of Perspective

Point of Perspective

Viewpoint WC2 Summer Single Frame 50mm Reference image

Camera Location:

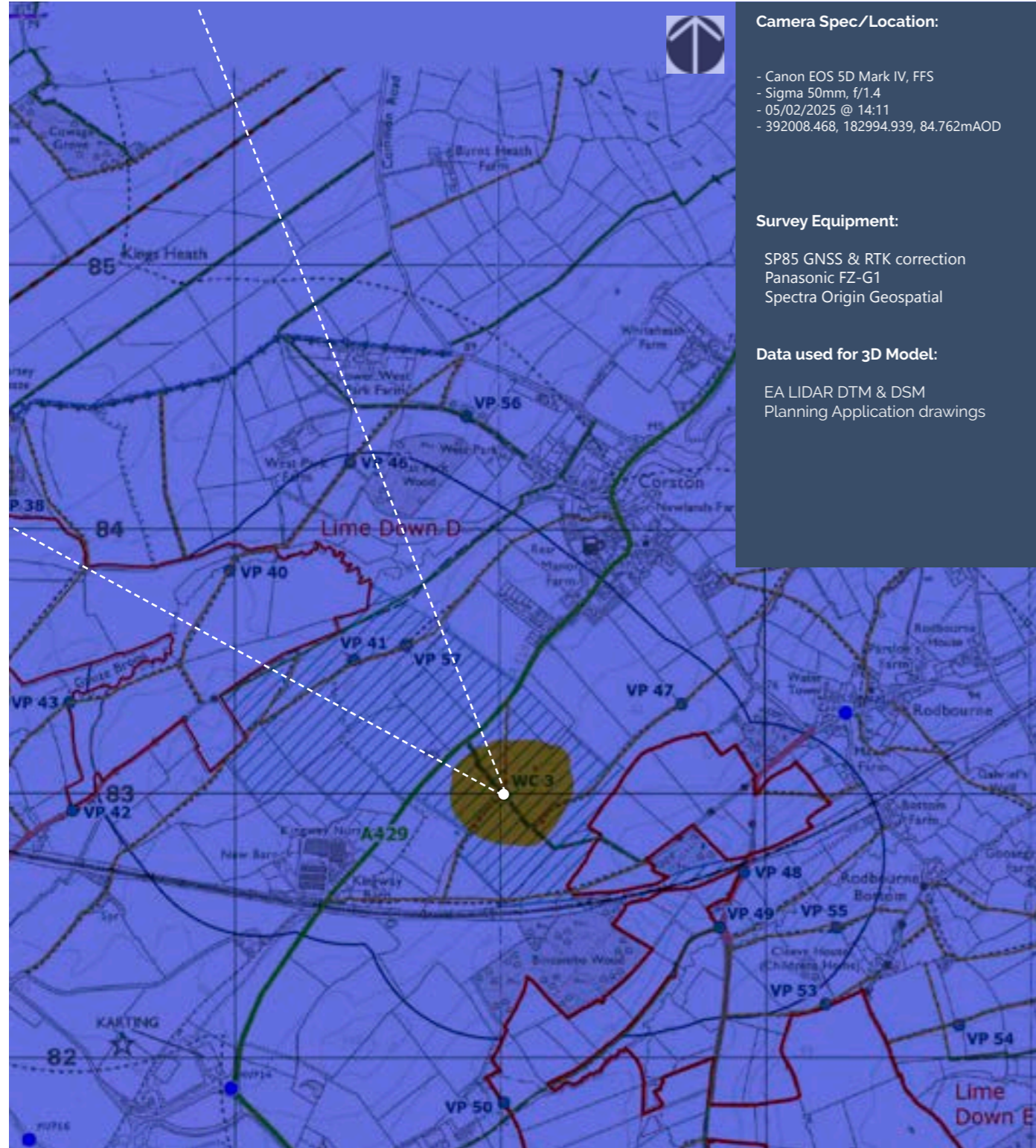

Camera Spec/Location:

- Canon EOS 5D Mark IV, FFS
- Sigma 50mm, f/1.4
- 05/02/2025 @ 14:11
- 392008.468, 182994.939, 84.762mAOD

Survey Equipment:

- SP85 GNSS & RTK correction
- Panasonic FZ-G1
- Spectra Origin Geospatial

Data used for 3D Model:

- EA LIDAR DTM & DSM
- Planning Application drawings

© Crown Copyright and database rights 2025 Ordnance Survey 0100031673

Tripod:



50mm Lens Planar Projection (actual 49.6mm; 39.9 deg HFOV)



Point of Perspective

Point of Perspective

Point of Perspective

Point of Perspective

Viewpoint WC3 Winter Single Frame 50mm Reference image

Camera Location:

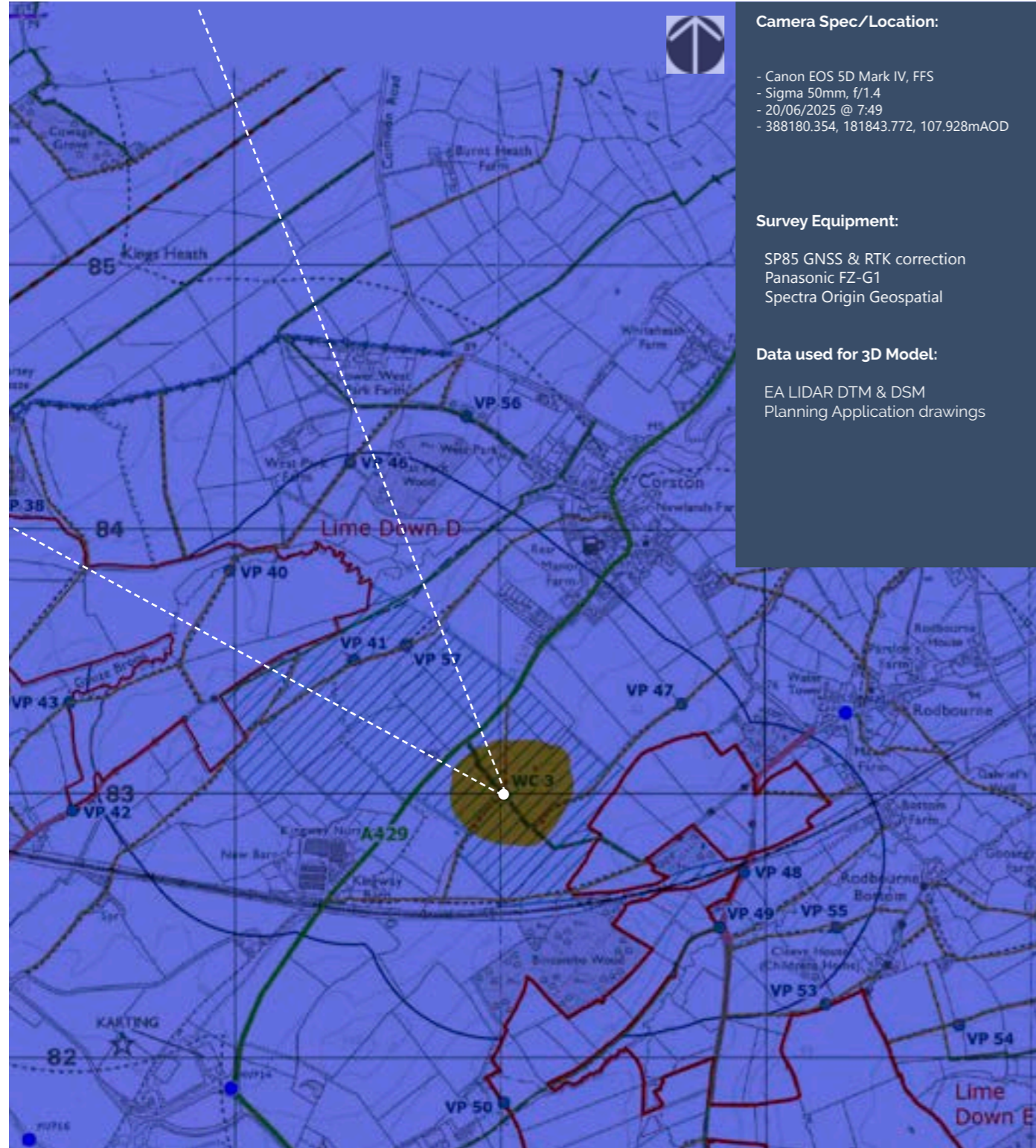

Camera Spec/Location:

- Canon EOS 5D Mark IV, FFS
- Sigma 50mm, f/1.4
- 20/06/2025 @ 7:49
- 388180.354, 181843.772, 107.928mAOD

Survey Equipment:

- SP85 GNSS & RTK correction
- Panasonic FZ-G1
- Spectra Origin Geospatial

Data used for 3D Model:

- EA LIDAR DTM & DSM
- Planning Application drawings

Crown Copyright and database rights 2025 Ordnance Survey 0100031673

Tripod:



50mm Lens Planar Projection (actual 49.6mm; 39.9 deg HFOV)



Point of Perspective

Point of Perspective

Point of Perspective

Point of Perspective

Viewpoint WC3 Summer Single Frame 50mm Reference image